

# SWITCHBLADE

## HARDWARE REFERENCE

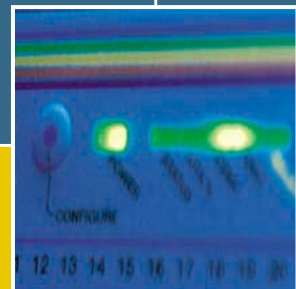
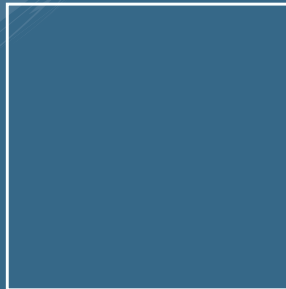

SwitchBlade Hardware Reference  
Document Number C613-03060-00 REV D3.

Copyright © 2002-2003 Allied Telesyn International, Corp. 19800 North Creek Parkway,  
Suite 200, Bothell, WA 98011, USA.

All rights reserved. No part of this publication may be reproduced without prior written permission from Allied Telesyn.

Allied Telesyn International, Corp. reserves the right to make changes in specifications and other information contained in this document without prior written notice. The information provided herein is subject to change without notice. In no event shall Allied Telesyn be liable for any incidental, special, indirect, or consequential damages whatsoever, including but not limited to lost profits, arising out of or related to this manual or the information contained herein, even if Allied Telesyn has been advised of, known, or should have known, the possibility of such damages.

All trademarks are the property of their respective owners.

# Contents

---

Contents .....	1
Models Covered by this Reference .....	3
Why You Should Read this Reference .....	4
Where to Find More Information .....	4
SwitchBlade Overview .....	5
Key Hardware Components .....	5
Chassis Models .....	5
Power Supplies .....	7
Switching Performance and Characteristics .....	7
Master Switch Controller and Slave Switch Controller Interactions .....	8
Hot Swapping .....	9
Physical and Operating Specifications .....	9
AT-SB4108 SwitchBlade 8 Card Chassis .....	9
AT-SB4104 SwitchBlade 4 Slot Chassis .....	11
AT-SB4161 & 2 SwitchBlade Power Supply Units .....	13
AT-SB4152 Fan Tray (For SwitchBlade 8) .....	15
AT-SB4151 Fan Tray (For SwitchBlade 4) .....	15
AT-SB4211 Switch Controller .....	16
AT-SB4215 Bandwidth Expander .....	17
AT-SB4311 48-Port (RJ-45) Fast Ethernet Line Card .....	18
AT-SB4352 32-Port (MT-RJ) Fast Ethernet Line Card .....	19
AT-SB4411 8-Port (RJ-45) Gigabit Ethernet Line Card .....	20
AT-SB4412 24-Port (RJ-45) Gigabit Ethernet Line Card .....	21
AT-SB4441 8-GBIC Line Card .....	22
AT-SB4451 8-port SX (SC) and AT-SB4461 8-Port LX (SC) Gigabit Ethernet Line Cards .....	23
AT-SB4452 8-port SX (MT-RJ) and AT-SB4462 8-Port LX (MT-RJ) Gigabit Ethernet Line Cards .....	24
Alarm Relays and Monitoring .....	25
Alarm Relays .....	25
Monitoring .....	26
How Many PSUs do You Need? .....	26
Online Documentation .....	26
Accessing the CD-ROM and Online Documentation .....	26
AT-TFTP Server .....	27
Switch Start-up .....	28
To log In .....	28
To access help .....	29
Start-up Procedures .....	30
Management Interfaces .....	32
RS-232 Terminal Port (ASYNO) .....	32
RJ-45 Management Port (ETH0) .....	33
Useful Cables .....	34
RS-232 Terminal and Modem Cables .....	34
Cables for RJ-45 Ethernet LAN Interfaces .....	36
Test Facility .....	38
Ethernet LAN Port Tests .....	38
Other Interface Tests .....	39
Troubleshooting .....	40
LEDs and What They Mean .....	40
Check these first .....	43
Some common problems and how to solve them .....	43
Expansion Options .....	45
Content Addressable Memory (CAM) .....	45
Installing CAM .....	46
Testing the CAM Card .....	49
Dual In-line Memory Modules (DIMMs) .....	52

Installing DIMM .....	52
Testing DIMM .....	53
Gigabit Interface Converters (GBICs) .....	54
Port, Connector, and Cable Combinations .....	55
Using Windows Terminal and Windows Hyperterminal .....	56
Restricted Procedures .....	59
Diagnostics .....	59
Contacting Us .....	60

## Documentation Roadmap

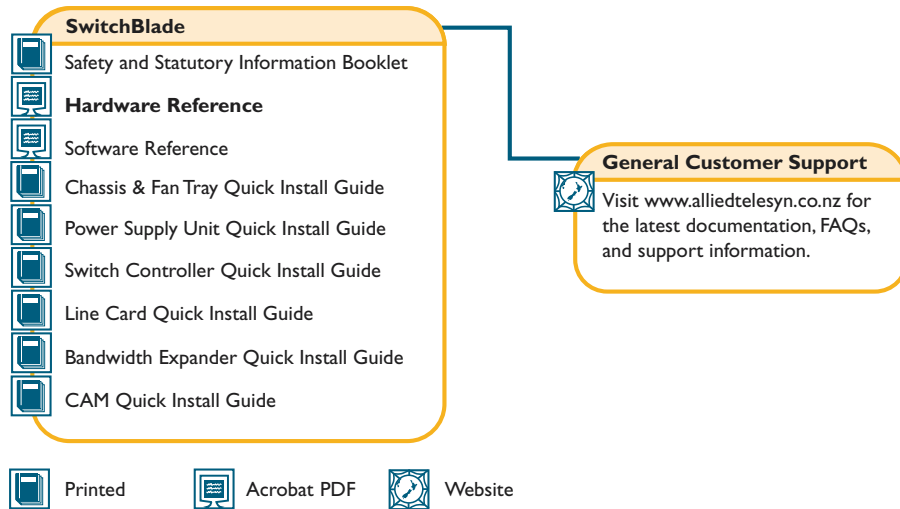

## Models Covered by this Reference

This Hardware Reference includes information on the following SwitchBlade components:

- AT-SB4108-00 SwitchBlade 8 Triple AC Feed Chassis
- AT-SB4108-60 SwitchBlade 8 Dual AC Feed Chassis
- AT-SB4108-80 SwitchBlade 8 Dual DC Feed Chassis
- AT-SB4104-00 SwitchBlade 4 AC Chassis
- AT-SB4104-80 SwitchBlade 4 DC Chassis
- AT-SB4152 SwitchBlade 8 Fan Tray
- AT-SB4151 SwitchBlade 4 Fan Tray
- AT-SB4211 Switch Controller
- AT-SB4215 Bandwidth Expander
- AT-SB4311 48-port 10BASE-T/100BASE-TX (RJ-45) Line Card
- AT-SB4352 32-port 100BASE-FX (MT-RJ) Line Card
- AT-SB4411 8-port 10BASE-T/100BASE-TX/1000BASE-T (RJ-45) Line Card
- AT-SB4441 8-port 1000BASE-X (GBIC) Line Card
- AT-SB4451 8-port 1000BASE-SX (SC) Line Card
- AT-SB4452 8-port 1000BASE-SX (MT-RJ) Line Card
- AT-SB4461 8-port 1000BASE-LX (SC) Line Card
- AT-SB4462 8-port 1000BASE-LX (MT-RJ) Line Card
- AT-SB4161 SwitchBlade AC Power Supply Unit
- AT-SB4162 SwitchBlade AC Power Supply Unit
- AT-SB4161-80 SwitchBlade DC Power Supply Unit

## ■ AT-SB4162-80 SwitchBlade DC Power Supply Unit

The latest SwitchBlade Hardware Reference can be found at [www.alliedtelesyn.co.nz/support/switchblade/](http://www.alliedtelesyn.co.nz/support/switchblade/).

## Why You Should Read this Reference

---

This reference provides hardware related information for the SwitchBlade, including information on the chassis, switch controllers, line cards, power supplies, and fan tray.

The reference has two primary aims:

1. To familiarise you with the SwitchBlade's hardware features.
2. To assist you with setting up and maintaining your SwitchBlade's hardware.

Step by step instructions for installing specific SwitchBlade components (such as switch controllers and line cards) can be found in the Quick Install Guide for each component.



---

*Keep this reference (or its CD-ROM) in a safe place, you will need it if you purchase switch expansion options (such as line cards) in the future.*

---



---

*This reference does not cover software configuration or software installation procedures. For information on software, refer to the SwitchBlade Software Reference.*

---

## Where to Find More Information

---

The Documentation and Tools CD-ROM bundled with each switch controller and chassis contains the complete document set for the switch and its expansion options, as well as tools for managing the switch. This includes the following:

- *SwitchBlade Safety Booklet* - Provides safety and statutory information.
- *SwitchBlade Software Reference* - Provides detailed information on configuring the switch and its software.
- *SwitchBlade Chassis and Fan Tray Quick Install Guide* - Outlines the procedure for installing chassis and fan trays.
- *SwitchBlade Switch Controller Quick Install Guide* - Outlines the procedure for installing switch controllers.
- *SwitchBlade Line Card Quick Install Guide* - Outlines the procedure for installing line cards.
- *SwitchBlade Power Supply Unit Quick Install Guide* - Outlines the procedure for installing AC and DC PSUs.
- *SwitchBlade Bandwidth Expander Quick Install Guide* - Outlines the procedure for installing bandwidth expanders.
- *CAM Quick Install Guide* - Outlines the procedure for installing content addressable memory.



























## AT-SB4311 48-Port (RJ-45) Fast Ethernet Line Card

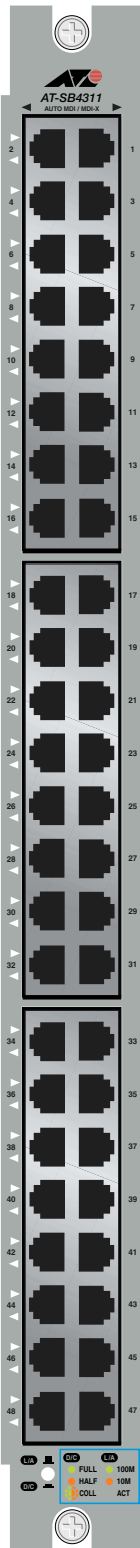

AT-SB4311 Line Card

### Weight

- 2.2 kg

### Ports

- 48 auto-negotiating 10BASE-T/100BASE-TX ports
- Auto MDI/MDI-X negotiation as default (MDI-X if negotiation is disabled)
- RJ-45 connectors

### LEDs

- Single (switchable) dual-mode LED per port
- Indicates full/half duplex, collisions, and link activity and bps speed (10/100)
- For a complete list of LEDs and their functions, see “LEDs and What They Mean” on page 40

### Switching

- Two ASIC switch chips operating in Layer 3 mode
- 40 k entry forwarding address database
- Support for protocol-based VLANs and MAC address learning
- 128 MByte RAMBUS packet buffer
- Either 33 MHz or 40 MHz, depending on the speed of the master card’s PCI bus

## AT-SB4352 32-Port (MT-RJ) Fast Ethernet Line Card

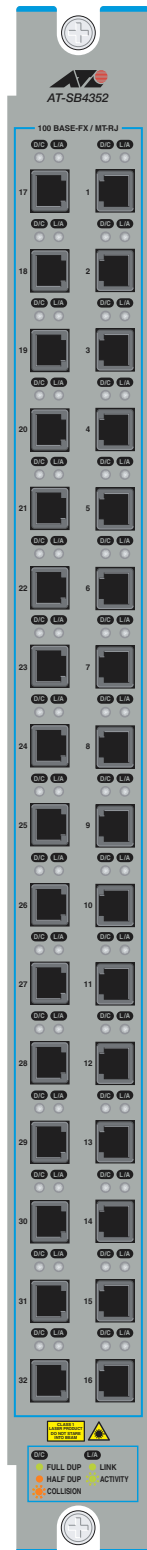

AT-SB4352 Line Card

### Weight

- 2.2 kg

### Ports

- Thirty-two 100BASE-FX ports
- MT-RJ connectors

### LEDs

- Two per port
- Indicate full/half duplex, collisions, and link activity
- For a complete list of LEDs and their functions, see “LEDs and What They Mean” on page 40

### Switching

- Two ASIC switch chips operating in Layer 3 mode
- 40 k entry forwarding address database
- Support for protocol-based VLANs and MAC address learning
- 128 MByte RAMBUS packet buffer
- Either 33 MHz or 40 MHz, depending on the speed of the master card’s PCI bus

## AT-SB4411 8-Port (RJ-45) Gigabit Ethernet Line Card

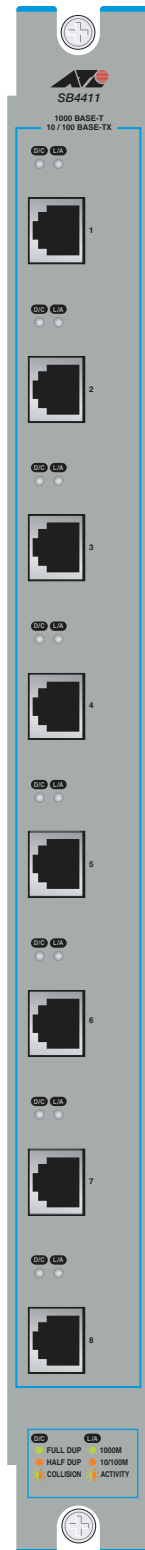

AT-SB4411 Line Card

### Weight

- 2.2 kg

### Ports

- Eight auto-negotiating, or manually configurable, ports: 10BASE-T (full duplex or half duplex)/100BASE-TX (full duplex or half duplex)/1000BASE-T (full duplex or half duplex)
- Auto MDI/MDI-X negotiation as default (MDI-X if negotiation is disabled)
- RJ-45 connectors

### LEDs

- Two per port
- Indicate full/half duplex, collisions, and link activity and Mbps speed (10/100/1000)
- For a complete list of LEDs and their functions, see “LEDs and What They Mean” on page 40

### Switching

- ASIC switch chip operating in Layer 3 mode
- 40 k-entry L2/L3 forwarding address database, expandable to 232 k-entries by adding a line card CAM extender card (LineCam)
- Support for protocol-based VLANs and MAC address learning
- 64 MByte RAMBUS packet buffer
- Either 33 MHz or 40 MHz, depending on the speed of the master card’s PCI bus

## AT-SB4412 24-Port (RJ-45) Gigabit Ethernet Line Card

### Weight

- 2.4 kg

### Ports

- Twenty four auto-negotiating, or manually configurable, ports: 10BASE-T/100BASE-TX/1000BASE-T - all able to operate in either full duplex or half duplex mode
- Auto MDI/MDI-X as default (MDI-X if auto-negotiation is disabled)
- RJ-45 connectors

### LEDs

- Two per port
- Indicate full/half duplex, collisions, and link activity and Mbps speed (10/100/1000)
- For a complete list of LEDs and their functions, see “LEDs and What They Mean” on page 40

### Switching

- Two ASIC switch chips operating in Layer 3 mode and at wire speed
- 40 k-entry, CAM based, non extendable, L2/L3 forwarding address database.
- VLAN support, based on: protocol, port, IP subnet, and MAC address.
- 64 MByte RAMBUS packet buffer, enabling traffic bursting to be absorbed
- Either 33 MHz or 40 MHz, depending on the speed of the master card's PCI bus

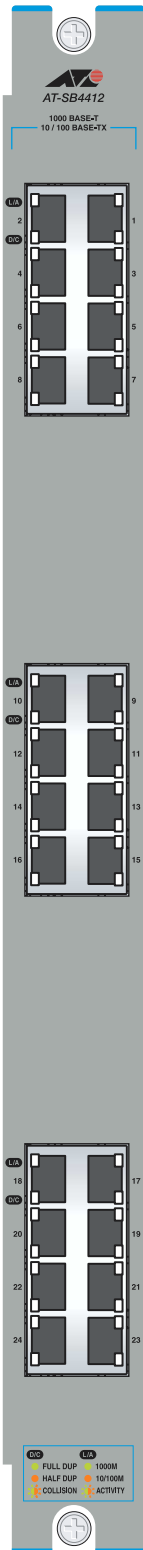

AT-SB4412 Line Card

## AT-SB4441 8-GBIC Line Card

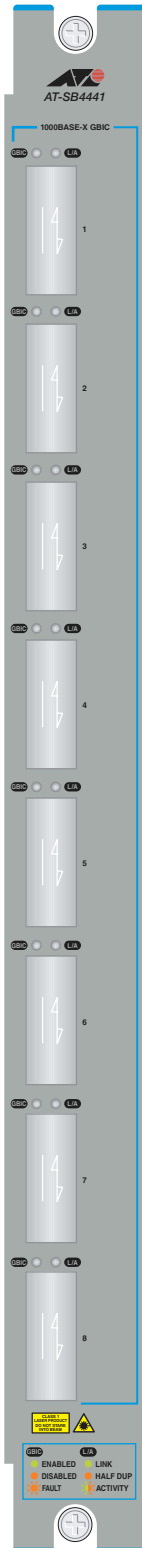

AT-SB4441 Line Card

### Weight

- 2.2 kg

### Ports

- Eight 1000BASE ports
- Compatible with copper (1000BASE-T) and fibre (1000BASE-SX and 1000BASE-LX) GBICs
- Compatible with RJ-45, SC, and LC connectors
- For use with Ethernet 5 V GBIC connectors

### LEDs

- Two per port
- Indicate link activity, half duplex, and GBIC status
- For a complete list of LEDs and their functions, see “LEDs and What They Mean” on page 40

### Switching

- ASIC switch chip operating in Layer 3 mode
- 40 k-entry forwarding address database, expandable to 232 k-entries by adding a line CAM extender card (LineCAM)
- Support for protocol-based VLANs and MAC address learning
- 64 MByte RAMBUS packet buffer
- Either 33 MHz or 40 MHz, depending on the speed of the master card’s PCI bus

## AT-SB4451 8-port SX (SC) and AT-SB4461 8-Port LX (SC) Gigabit Ethernet Line Cards

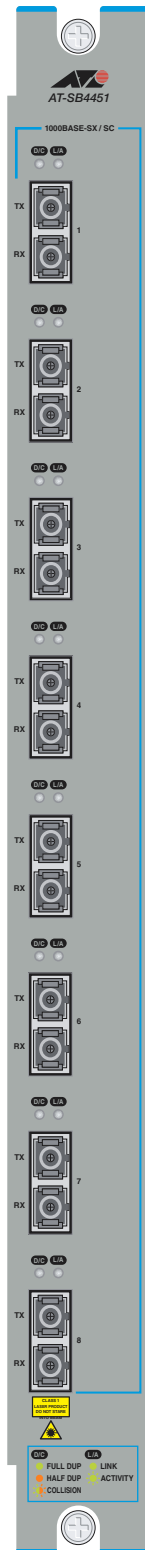

AT-SB4451 Line Card

### Weight

- 2.2 kg

### Ports

- Eight 1000BASE-SX ports (AT-SB4451) or eight 1000BASE-LX (AT-SB4461)
- SC connectors

### LEDs

- Two per port
- Indicate full/half duplex, collisions, and link activity
- For a complete list of LEDs and their functions, see “LEDs and What They Mean” on page 40

### Switching

- ASIC switch chip operating in Layer 3 mode
- 40 k-entry forwarding address database, expandable to 232 k-entries by adding a line CAM extender card (LineCAM)
- Support for protocol-based VLANs and MAC address learning
- 64 MByte RAMBUS packet buffer
- Either 33 MHz or 40 MHz, depending on the speed of the master card’s PCI bus

## AT-SB4452 8-port SX (MT-RJ) and AT-SB4462 8-Port LX (MT-RJ) Gigabit Ethernet Line Cards

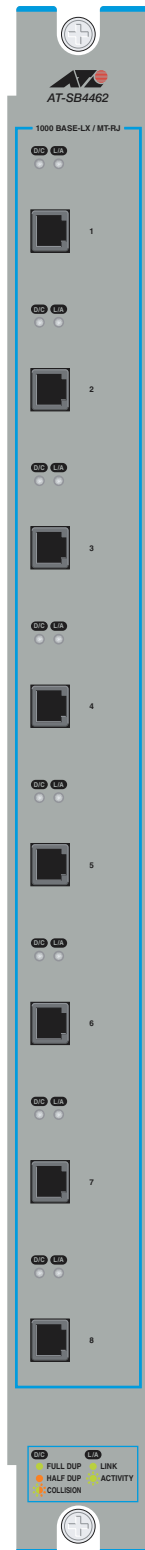

AT-SB4462 Line Card

### Weight

- 2.2 kg

### Ports

- Eight 1000BASE-SX ports (AT-SB4452) or eight 1000BASE-LX (AT-SB4462)
- MT-RJ connectors

### LEDs

- Two per port
- Indicate full/half duplex, collisions, and link activity
- For a complete list of LEDs and their functions, see “LEDs and What They Mean” on page 40

### Switching

- ASIC switch chip operating in Layer 3 mode
- 40 k entry forwarding address database, expandable to 232 k-entries by adding a line CAM extender card (LineCAM)
- Support for protocol-based VLANs and MAC address learning
- 64 MByte RAMBUS packet buffer
- Either 33 MHz or 40 MHz, depending on the speed of the master card’s PCI bus

# Alarm Relays and Monitoring

This section provides an introduction to the SwitchBlade’s alarm and monitoring capabilities. All SwitchBlade chassis have two alarm relays on their rear panel, and extensive software-based logging, SNMP trap, and trigger monitoring capability.

## Alarm Relays

The SwitchBlade’s two alarm relays (“Major” and “Minor”) can be configured to operate when a number of different environmental and operational events occur. Users can choose which relay (major or minor) operates for a specific event. The relays do not operate by default, they will only operate if specifically configured to do so.

The relays are designed to operate in DC circuits. When placed in these circuits the relays can operate external alarm devices such as small alarms, lights, or larger relays. If connecting the relays to a 12VDC circuit, they can switch 1 amp. If connecting the relays to a 48VDC circuit, they can switch 0.5 amp. The relays have normally open (N/O) and normally closed (N/C) contact options.



**Connecting the relays to an AC circuit is likely to damage the relays and switch.**

Table 2 on page 25 lists the events that can operate alarms. Refer to “System Monitoring” on page 1-27 of *Chapter 1, OperationSwitch* for information on configuring alarm relays, including complete command descriptions.

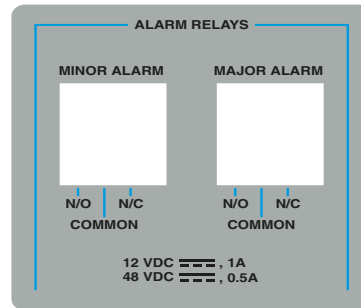

**Table 2: Alarm and monitoring events.**

Event	Description
Fan tray presence	Initiates an alarm event if a fan tray is removed for more than 20 seconds. Initiates a monitoring event when a fan tray is removed.
Fan tray fan status	Initiates alarm and or monitoring events when a fan tray fan fault is detected.
Fixed CPU high temperature	Initiates alarm and or monitoring events if CPU temperature rises above 90° C (194° F). Temperature is measured at the master switch controller CPU and slave switch controller CPU.

**Table 2: Alarm and monitoring events.**

Event	Description
Settable CPU Temperature	Initiates alarm and or monitoring events if CPU temperature rises above a value defined by the user. Temperature is measured at the master switch controller CPU and slave switch controller CPU.
Power Supply Unit status	Initiates alarm and or monitoring events when a Power Supply Unit fault is detected.
Power Supply Unit fan status	Initiates alarm and or monitoring events when a PSU fan fault is detected.
Port status	Initiates alarm and or monitoring events when a specified port goes down.
Command port (Asyn 0) status	Initiates alarm and or monitoring events when a user logs into Asyn 0 on the master switch controller.

## Monitoring

In addition to operating an alarm, the events listed in Table 2 on page 25 can also be monitored. Users can configure monitored events to generate any combination of SNMP traps, logging events, and triggers. Monitoring does not occur by default, users must configure each event that is to be monitored. The *SwitchBlade Software Reference* has more information on monitoring, including complete command descriptions.

## How Many PSUs do You Need?

The number of PSU's required depends on the chassis type and the particular configuration selected, i.e. the number of line cards, controller cards and CAM modules installed. Consult your authorised Allied Telesyn distributor or reseller for more information.

For PSU specifications and maximum current loads, see "AT-SB4161 & 2 SwitchBlade Power Supply Units" on page 13.

## Online Documentation

This section provides a step-by-step guide to accessing online documentation. Adobe Acrobat Reader must be installed to view online documentation.

### Accessing the CD-ROM and Online Documentation

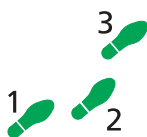

Follow these steps to access the CD-ROM and online documentation:

1. Insert the Documentation and Tools CD-ROM in the CD-ROM drive.
2. If the Welcome screen does not appear.  
Select "Run" from the Start Menu (Windows 95, 98, 2000 or NT 4.0).

Type `d:\start.exe` (where `d:` is the CD-ROM drive letter) and click OK.

**3. To view a document.**

Click on the document title.

**4. To navigate around PDF documents.**

Use the toolbar buttons, keyboard shortcuts, or commands from the Document menu to page through the document.

Click on a bookmark, thumbnail or hypertext link to jump to a specific section or topic.

Use the Search command to search for keywords or phrases.

For more information about using the Adobe Acrobat Reader, select "Reader Guide" from the Help menu.

**5. To install any of the tools included on the CD-ROM.**

Click on a link in the Welcome screen.

---

## AT-TFTP Server

---

This section provides information on how to access and use AT-TFTP Server. AT-TFTP Server can be used to transfer configuration files as well as to download software patches and releases.

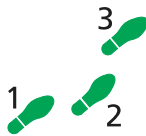

**To use AT-TFTP Server, follow these steps:**

**1. If AT-TFTP Server has not yet been installed.**

Install it now from the SwitchBlade Documentation and Tools CD-ROM.

Choose AT-TFTP Server from the Start > Programs > Allied Telesyn > AT-TFTP Server menu.

**2. To set preferences for the AT-TFTP Server.**

Select "Options" from the File menu to display the "Set Preferences" dialog box.

The "Default file transfer directory" field specifies the directory that AT-TFTP Server will read from or write to for file requests that do not include a directory specification.

To prevent unauthorised access to private directories, enter a path name in the "Restrict to directory" field. AT-TFTP Server will use only the specified directory, even if file requests contain references to other directories.

Select "Read only" to prevent files being written to the PC. To use the PC to archive scripts created using the switch's CREATE CONFIG command, select "Read Write".

Make any required changes and click "OK".

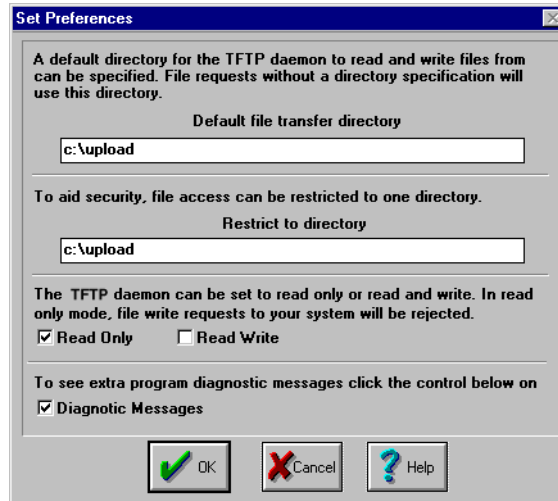

### 3. To load a file from AT-TFTP Server to the Switch.

On a terminal connected to the master switch controller's RS-232 ASYN0, type the command:

```
LOAD METHOD=TFTP FILE=filename SERVER=ipadd DEST=FLASH
```

where *filename* is the name of the file to download and *ipadd* is the IP address of the PC running AT-TFTP Server.

### 4. To save a TFTP Server log.

Select "Save As" from the File menu.

TFTP requests are logged to the AT-TFTP Server main window.

## Switch Start-up

---

This section outlines the log in and start-up procedures for your switch. Although the switch will perform basic switching operations without being configured, you will need to go through these log in and start-up procedures if you wish to configure the switch and access its full layer 3 switching capabilities.

Before you can log in, the switch's chassis must have at least one power supply unit, one fan tray, and one switch controller installed.

### To log In

To log in you must first connect the master switch controller to a terminal or PC. This can be done using the switch controller's RS-232 ASYN0. Two terminal cables suitable for use with ASYN0 are supplied with each chassis.



*If two switch controllers are installed, and the switch has not yet been connected to a power supply, the switch controller in Bay A will assume master controller status. In all cases the master controller is the controller whose Master LED is lit.*

---

Using the supplied terminal cable, or a cable you have made by following the instructions in “Useful Cables” on page 34, connect your terminal or PC to the RS-232 ASYN0 on the master switch controller.

Set the communication parameters on your terminal or terminal emulation program to:

- Baud rate: 9600
- Data bits: 8
- Parity: None
- Stop bits: 1
- Flow control: Hardware

See “Using Windows Terminal and Windows Hyperterminal” on page 56 for more information on configuring emulation software.

Ensure that the chassis’s stand-by switch is in the Run position and that the switch controller is receiving power.

After the switch controller has booted, the log in prompt appears. If the log in prompt doesn’t appear, press [Enter] two or three times.

When the switch boots for the first time it automatically creates an account with manager privileges. The account has the log in name “manager” and the password is “friend”.

At the log in prompt, enter the log in name and password.

```
Log in: manager
```

```
Password: friend
```

The switch’s command prompt appears and you can now configure the switch using the command line interface.



---

*Change the password as soon as possible. Leaving the manager account with the default password is a serious security risk. Make sure that you remember the new password as there is no way to retrieve it if it is lost.*

---

Use the following command to change the account password:

```
set password
```

See the *SwitchBlade Software Reference* for more information on configuring the switch.

## To access help

Before help is used for the first time, the help files must be defined.

To define the files, enter:

```
set help=help-filename
```

where *help-filename* is the name of a help file stored in flash.

To see a list of files stored in flash, enter:

```
show file
```

Help files have an HLP extension.

To display a list of help topics, enter:

```
help
```

To display help on a specific topic, enter:

```
help topic
```

Alternatively, type a question mark (?) at the end of a partially completed command to see a list of valid options.

## Start-up Procedures

When the switch starts up following either a power cycle or an operator-initiated reboot (using the Reset button or RESTART command), a series of start-up messages is sent to the terminal or PC connected to RS-232 ASYN0 (Figure 1 on page 30).

**Figure 1: Switch start-up messages.**

```
INFO: Self tests beginning.
INFO: RAM test beginning.
PASS: RAM test, 262144k bytes found.
INFO: BBR tests beginning.
PASS: BBR test, 512k bytes found.
INFO: Self tests complete
INFO: Downloading switch software.
Force EPROM download (Y) ?
INFO: Initial download succeeded
INFO: Executing configuration script <boot.cfg>
INFO: Switch startup complete

Manager >
```

After the self tests are complete, the manager is given the option of forcing a mandatory boot from the EPROM (Flash) release. The message:

```
Force EPROM download (Y) ?
```

is displayed on the terminal or PC connected to ASYN0 and the switch pauses. If a key is not pressed within a few seconds, the start-up process will continue and all steps in the sequence will be executed. Pressing selected keys on the terminal immediately after the “Force EPROM download” message is displayed will change the switch start-up process (Table 3 on page 30).

**Table 3: Switch start-up sequence keystrokes.**

Pressing key...	Forces the switch to...
[Y]	Load the EPROM release, with no patch.
[S]	Start with the default configuration. Any boot script is ignored.
[Ctrl/D]	Enter diagnostics mode.

During the start-up process the switch will generate four different types of messages. All messages are preceded by one of the words INFO, PASS, FAIL, or ERROR. The significance of these words is shown in Table 4 on page 31.

**Table 4: Switch start-up message classes.**

Message	Meaning
INFO	An action will be taken by the system.
PASS	A test has been completed successfully.
ERROR	An error message that a test has failed, but the system will continue to operate.
FAIL	An error message that a fatal error condition has caused the system to halt in an unrecoverable fashion.

The possible messages and their meanings are:

INFO: Self tests beginning.

The code loader tests are about to begin.

INFO: RAM test beginning.

The RAM tests are about to begin.

PASS: RAM test, 262144k bytes found.

The RAM test passed, and the indicated amount of memory was found and will be used by the switch.

ERROR: RAM test 5. Error address = 00345678.

A RAM test failed, at the given address. In the example, it was the fifth test run. The RAM test repeats until it passes, so a number of messages like this may appear. This fault means that the memory system is faulty. If the fault continues, contact your Authorised Allied Telesyn distributor or reseller immediately.

INFO: BBR tests beginning.

The BBR battery tests are about to begin.

PASS: BBR test. Battery OK.

The BBR battery tests passed.

ERROR: BBR Battery low.

The BBR battery test failed, indicating that the battery is running low. The BBR battery will need to be replaced. Contact your Authorised Allied Telesyn distributor or reseller.

PASS: BBR test, 512k bytes found.

The BBR size/location test passed, with the indicated amount of BBR found.

FAIL: BBR test. Error address = 12345678.

The BBR size/location test failed at the given location. The test at this location failed, indicating the end of memory, but a valid location was discovered in the 255 long words following this location. The BBR system will need to be replaced. Contact your Authorised Allied Telesyn distributor or reseller.

FAIL: BBR test, only 16k bytes found.

The BBR size/location test completed, but only the displayed amount of memory was found. This amount is less than the minimum required to run the switch software.

INFO: Self tests complete.

The start-up tests have finished.

INFO: Downloading switch software.

The process of downloading the switch software and vector table from ROM is about to begin.

ERROR: Code load retried.

FAIL: Code load failed.

The load of the code from ROM to RAM failed. The load is retried a number of times. Each time a failure occurs, the ERROR message is displayed. If the maximum number of attempts is reached, the FAIL message is displayed.

INFO: Initial download succeeded.

The start-up tests and download are complete, and the switch software is about to be started. If the default install is a compressed release, the release will now be decompressed. This may take a few seconds.

INFO: Downloading compressed release. This may take up to 1 minute...

INFO: Loading software into memory. This may take up to 1 minute...

The main switch software is about to be loaded into RAM. If the release is a compressed release, the release will be decompressed.

INFO: Executing configuration script <script-name>

The configuration commands stored in <script-name> are being executed. If an error is found in the script, one or more ERROR messages will be displayed.

INFO: Switch startup complete.

The start-up process is complete and the switch will now perform basic switching operations. Further configuration will be necessary if you wish to access the switch's full layer 3 switching capabilities. See the *SwitchBlade Software Reference* for detailed information on configuring the switch.

## Management Interfaces

---

This section introduces the switch controller's RS-232 Terminal Port (ASYN0) and RJ-45 port (ETH0), including their pin assignments.

### RS-232 Terminal Port (ASYN0)

The RS-232 ASYN0 Terminal Port can be used to connect the switch to a management device for initial configuration and switch management tasks. This allows the switch's software to be accessed from a terminal, a PC running terminal emulation software, or from a remote location via a modem connection. You can also use ASYN0 to establish a network connection from a remote site using SLIP and a modem.

ASYN0 has a DCE female socket. This allows the use of a straight-through cable when connecting the switch to a terminal or PC. Output from the SHOW ASYN command will, however, still have a DTE perspective. The internal DTE pin roles are listed in Table 5 on page 33. See "Useful Cables" on page 34 for more information on suitable cables to use with ASYN0.

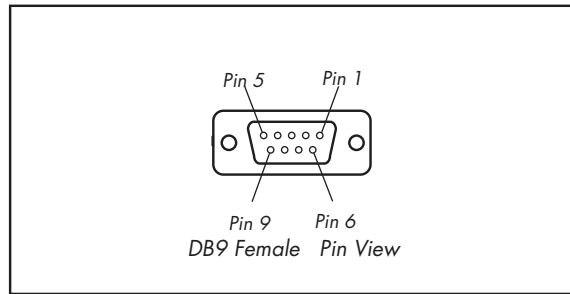
**Figure 2: RS-232 Terminal Port Pin Numbers.****Table 5: Internal DTE pin roles .**

Pin	Role
2	TXD
3	RXD
4	CD
5	GND
6	DTR
7	CTS
8	RTS

## RJ-45 Management Port (ETH0)



**Caution.** Do not plug a phone jack into any RJ-45 port. Doing so could damage the switch. Use only twisted pair cables with RJ-45 connectors.

The switch controller's 10BASE-T/100BASE-TX RJ-45 ETH0 port can be used to establish a connection to a dedicated network management LAN. ETH0 is not a switch port.

ETH0 has a default IP address of 192.168.242.242 and a mask of 255.255.255.0. For instructions on changing the IP address, see the "Graphical User Interface" section in the "Operations" chapter of the SwitchBlade Software Reference.



**As a security precaution, change the default IP address as soon as possible.**



**If another device on your network already uses 192.168.242.242, do not connect ETH0 to the network until you have changed its default address.**

A twisted pair straight-through cable with RJ-45 connectors should be used with ETH0. See Table 7 on page 34 list the cables described in this section. "Useful Cables" on page 34 for more information on suitable cables to use with ETH0.

Figure 3 on page 34 illustrates the pin layout for RJ-45 connectors, including ETH0.

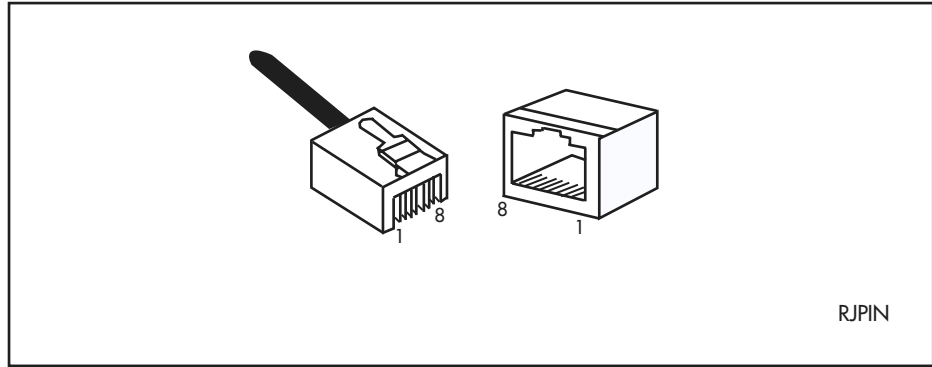
**Figure 3: RJ-45 Pin layout.**

With 10BASE-T/100BASE-TX cables, pins 1 and 2 are used for transmitting data, while pins 3 and 6 are used for receiving data. Table 6 on page 34 lists the RJ-45 Pin assignments.

**Table 6: RJ-45 Pin assignments.**

Pin Number	Assignment <sup>1</sup>
1	TX+
2	TX-
3	RX+
6	RX-

1. The "+" and "-" signs represent the polarity of the wires that make up each wire pair.

## Useful Cables

This section describes how to make management, test, and network cables for use with the switch's RS-232 (ASYN0) and RJ-45 interfaces.

### RS-232 Terminal and Modem Cables

Table 7 on page 34 list the cables described in this section.

**Table 7: Terminal and modem cable descriptions.**

Cable type	Description
RS-232 DB9 male to female terminal cable	Figure 4 on page 35
RS-232 DB9 male to male modem cable	Figure 5 on page 35

Figure 4 on page 35, and Figure 5 on page 35 show how to wire cables to connect a standard VT100 compatible terminal, or a modem, to the switch controller's RS-232 Terminal Port.

Figure 4: Pin wiring diagram for a standard DB9 male to female terminal cable.

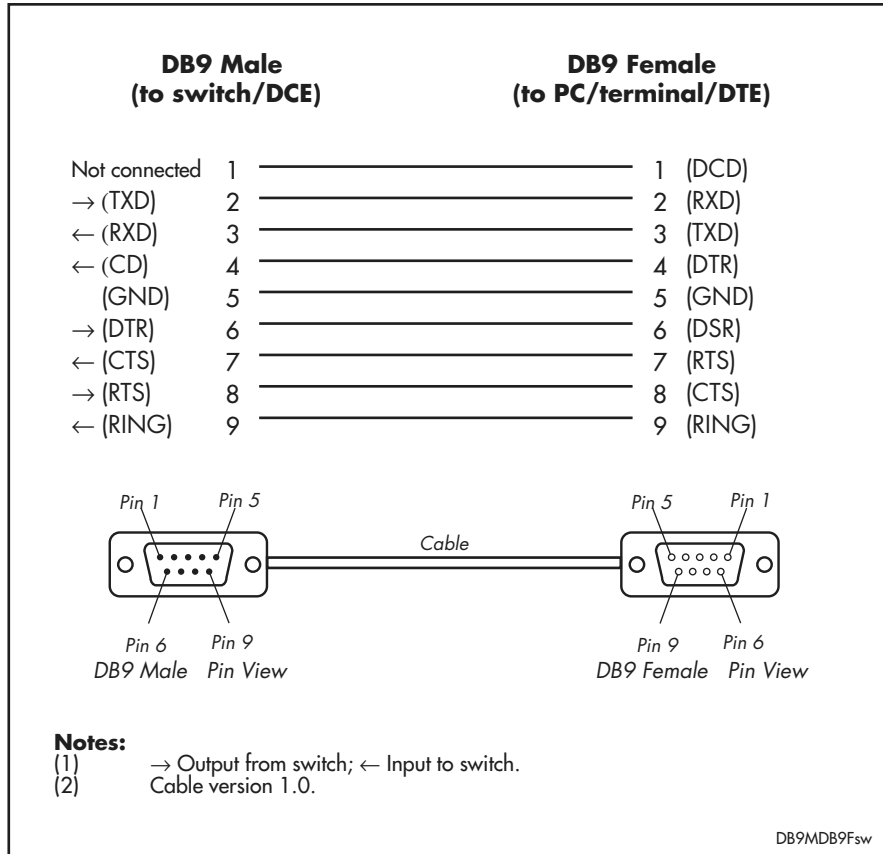
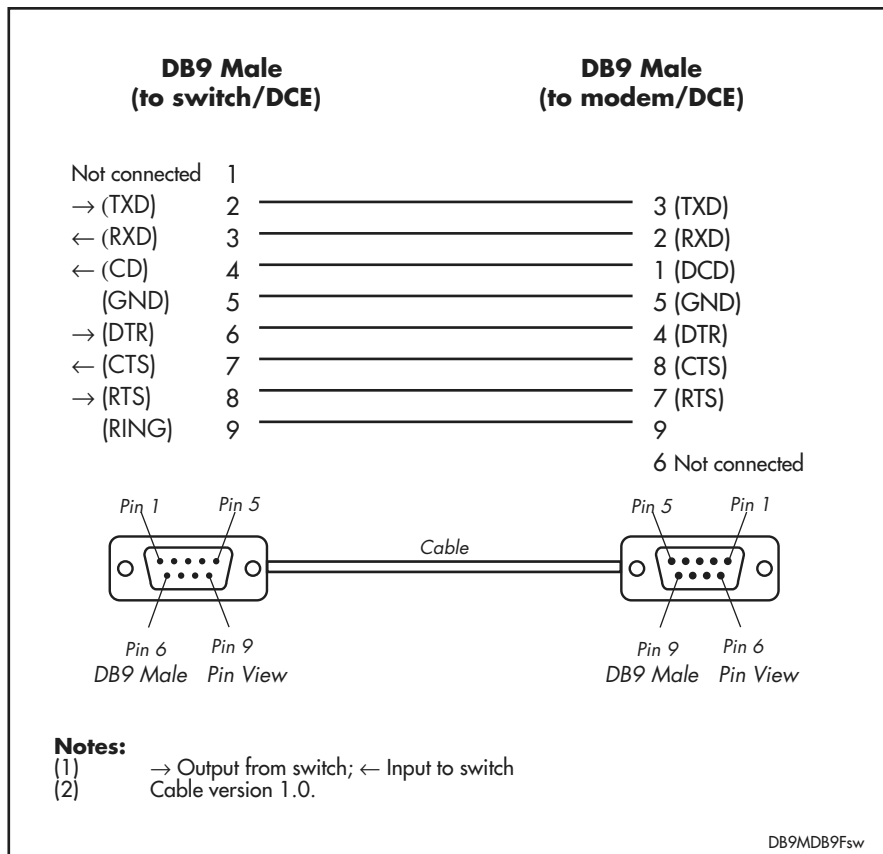

Figure 5: Pin wiring diagram for a DCE RS-232 Terminal Port (DB9 female connector) male to male modem cable.



More information on pin assignments for the RS-232 Terminal Port can be found in “Management Interfaces” on page 32.

## Cables for RJ-45 Ethernet LAN Interfaces

For all 10BASE-T/100BASE-TX (10/100BASE) and 10BASE-T/100BASE-TX/1000BASE-T (10/100/1000BASE) connections, a twisted pair cable with RJ-45 connectors must be used. 10/100BASE connections require at least two pairs to be used, while 10/100/1000 connections require four pairs.

Table 8 on page 36 lists the cables used for network connections and testing of RJ-45 interfaces.

**Table 8: Cables for RJ-45 LAN interfaces.**

Purpose	Interface type	Cable type	Pairs	Pin assignment
Network	10/100BASE	Crossover or straight through	Two or four	Table 10 on page 37 or Table 9 on page 37
Network	10/100/1000BASE	Straight through	Four	Table 11 on page 37
Test	10/100BASE	Crossover	Two or four	Table 10 on page 37 or Table 12 on page 38
Test	10/100/1000BASE	Crossover or straight through	Four	Table 12 on page 38 or Table 11 on page 37

### Pin assignments

For twisted pair cables each pair is identified by two different colours. For example, one wire might be red, and the other red with a white stripe. An RJ-45 connector must be fitted to both ends of the cable. Figure 6 on page 36 illustrates the pin layout for RJ-45 connectors.



**Caution.** Do not plug a phone jack into any RJ-45 port. Doing so could damage the switch. Use only twisted pair cables with RJ-45 connectors.

**Figure 6: RJ-45 Pin layout.**

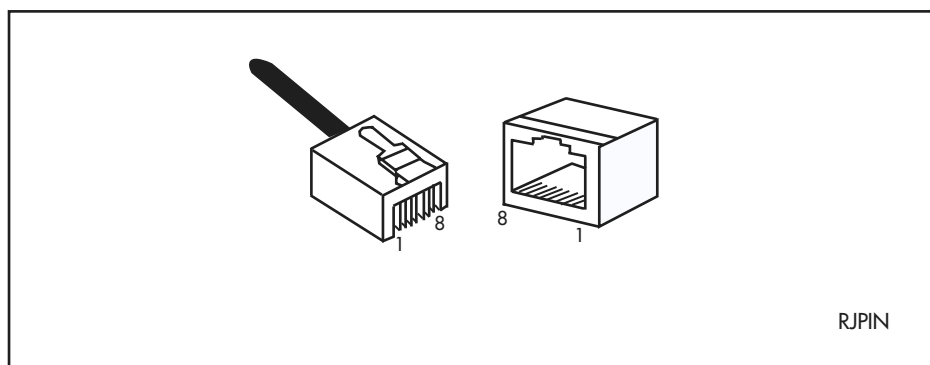

## 10/100BASE straight-through cable

If a twisted pair cable is to join two 10/100BASE network ports and only one of the ports has an internal crossover (only one port is labelled with an “X”), the two pairs should be straight through, as listed in Table 9 on page 37.

**Table 9: RJ-45 Pin assignments, two pair straight through cable.**

End 1	End 2
1 (TX+)	1 (TX+)
2 (TX-)	2 (TX-)
3 (RX+)	3 (RX+)
6 (RX-)	6 (RX-)

## 10/100BASE crossover cable

If a twisted pair cable is used to join two 10/100BASE network ports and either both ports are labelled with an “X” or neither port is labelled with an “X”, a crossover should be used. This cable is also used, in conjunction with the software test facility, to test 10/100BASE network and management ports. Table 10 on page 37 lists the RJ-45 crossover wiring pin assignments.

**Table 10: RJ-45 Pin assignments, two pair crossover cable.**

End 1	End 2
1 (TX+)	3 (TX+)
2 (TX-)	6 (TX-)
3 (RX+)	1 (RX+)
6 (RX-)	2 (RX-)

## 1000BASE straight-through cable

For 1000BASE network connections, all four pairs are used and the cable is wired in a straight-through configuration. This cable can also be used, in conjunction with the software test facility, to test 1000BASE network ports. Table 11 on page 37 lists the pin assignments.

**Table 11: Pin assignments, 10/100/1000BASE-T RJ-45 four pair straight-through cable<sup>1</sup>.**

End 1		End 2	
Pin	Pair	Pin	Pair
1	Pair 1+	1	Pair 1+
2	Pair 1-	2	Pair 1-
3	Pair 2+	3	Pair 2+
6	Pair 2-	6	Pair 2-
4	Pair 3+	4	Pair 3+
5	Pair 3-	5	Pair 3-
7	Pair 4+	7	Pair 4+
8	Pair 4-	8	Pair 4-

## 1000BASE crossover cable

For 1000BASE test cables, all four pairs are used and the cable is wired in a crossover configuration. This cable can also be used, in conjunction with the software test facility, to test 10/100BASE network ports. Table 12 on page 38 lists the pin assignments.

**Table 12: Pin assignments, 10/100/1000BASE-T RJ-45 four pair crossover cable<sup>1</sup>.**

End 1		End 2	
Pin	Pair	Pin	Pair
1	Pair 1+	1	Pair 2+
2	Pair 1-	2	Pair 2-
3	Pair 2+	3	Pair 1+
6	Pair 2-	6	Pair 1-
4	Pair 3+	4	Pair 4+
5	Pair 3-	5	Pair 4-
7	Pair 4+	7	Pair 3+
8	Pair 4-	8	Pair 3-

1. This cable can also be used with 10/100BASE interfaces.

## Test Facility

This section introduces the Test Facility. The Test Facility is built into all SwitchBlade software. For detailed information on operating the Test Facility, see the *Test Facility* chapter of the *SwitchBlade Software Reference*.

Any interfaces being tested are dedicated to the Test Facility. The Test Facility can be thought of as a specialised interface module like PPP or Frame Relay.

## Ethernet LAN Port Tests

A crossover cable is required to run an Ethernet LAN test. See “Useful Cables” on page 34 for details of how to make a suitable cable. To start the test, loop a crossover cable between any two RJ-45 line card ports and enter:

```
ENABLE TEST INT=ALL
```

All interfaces connected by crossover cables are tested. Test results are displayed with the command:

```
SHOW TEST INT
```

which produces a display like that shown in Figure 7 on page 39. A more detailed output (with frame counts) can be displayed with the command:

```
SHOW TEST COUNT
```

which is shown in Figure 8 on page 39.

**Figure 7: Example output from the SHOW TEST INT command on an AT-SB4411 with ports 3.1 and 3.2 linked by a crossover cable.**

Board	ID	Bay	Board Name	Rev	Serial number	
Base	164		AT-SB4411	M1-0	50433214	
Interface	State	Result	Type	Duration (minutes)	Details Data( %OK )	Control
eth0	testing	wait 4 minutes	trans	0	- -	-
			TP	< 1	BAD ( 0.0)	-
			ENDEC	0	- -	-
			MAC	< 1	good(100.0)	- .
port3.1	testing	wait 4 minutes	TP	< 1	good(100.0)	- .
port3.2	testing	wait 4 minutes	TP	< 1	good(100.0)	- .
port3.3	no test	-	-	-	- -	-
port3.4	no test	-	-	-	- -	-
port3.5	no test	-	-	-	- -	-
port3.6	no test	-	-	-	- -	-
port3.7	no test	-	-	-	- -	-
port3.8	no test	-	-	-	- -	-

**Figure 8: Example output for the SHOW TEST COUNT command.**

Board	ID	Bay	Board Name	Rev	Serial number		
Base	164		AT-SB4411	M1-0	50433214		
Interface	State	Type	Duration (minutes)	Tx	Frame Counters RxTotal	RxGood	RxBad
eth0	testing	trans	0	000000000	000000000	000000000	000000000
		TP	< 1	000000047	000000046	000000000	000000046
		ENDEC	0	000000000	000000000	000000000	000000000
		MAC	0	000000000	000000000	000000000	000000000
port3.1	testing	TP	< 1	000114290	000114289	000114289	000000000
port3.2	testing	TP	< 1	000114290	000114289	000114289	000000000
port3.3	no test	-	-	-	-	-	-
port3.4	no test	-	-	-	-	-	-
port3.5	no test	-	-	-	-	-	-
port3.6	no test	-	-	-	-	-	-
port3.7	no test	-	-	-	-	-	-
port3.8	no test	-	-	-	-	-	-

## Other Interface Tests

Refer to the *Test Facility* of the *SwitchBlade Software Reference* for information on testing other interfaces.



*If a test fails, please contact your Authorised Allied Telesyn distributor or reseller.*

## Troubleshooting

This section provides information on how to detect and resolve problems with the SwitchBlade and its expansion options.

Other sources of useful troubleshooting information are:

- [www.alliedtelesyn.co.nz/support/switchblade/](http://www.alliedtelesyn.co.nz/support/switchblade/).
- *The SwitchBlade Software Reference.*

## LEDs and What They Mean

The following tables outline how SwitchBlade LEDs report faults and operational activities.

### Switch Controller LEDs

The following LEDs will operate if the switch controller is receiving power.

**Table 13: LEDs on the AT-SB4211 Switch Controller.**

LED	State	Function
Power	Green	The switch controller is receiving power
Master	Amber	The switch controller is the master controller
	Off	The switch controller is the slave controller
Fault	Red	The switch controller or management software is malfunctioning
	2 Flashes <sup>1</sup>	A fan-tray fan has failed
	3 Flashes <sup>1</sup>	A PSU or PSU fan is malfunctioning
	5 flashes <sup>1</sup>	The fan tray has been removed for more than 20 seconds
	6 Flashes <sup>1</sup>	The switch's internal temperature has exceeded the alarm threshold
	Slow flashing at startup	The SDRAM (DIMM) has not been detected
	Rapid flashing at startup	The SDRAM (DIMM) is not compatible with the switch
L/A (Link/Activity)	Green	A 100 Mbps management port link is open
	Amber	A 10 Mbps management port link is open
	Flashing green	100 Mbps activity is occurring through the management port
	Flashing amber	10 Mbps activity is occurring through the management port

**Table 13: LEDs on the AT-SB4211 Switch Controller. (Continued)**

LED	State	Function
D/C (Duplex/Collision)	Green	The management port is operating at full-duplex
	Amber	The management port is operating at half-duplex
	Flashing	Collisions are occurring on the management port link

1. Appears on both controller cards.

## Line Card LEDs

The following LEDs will operate if the line card is installed in conjunction with a properly configured switch controller and at least one functional PSU (or a DC power supply for DC models).

**Table 14: AT-SB4411 8-port 10/100/1000BASE (RJ-45) Line Card .**

LED	State	Function
L/A (Link/Activity)	Green	A 1000 Mbps link is open
	Flashing green	1000 Mbps activity is occurring
	Amber	A 10/100 Mbps auto-negotiating link is open. The L/A LED for port 1 briefly lights at switch power up or when the card is hot swapped in
	Flashing amber	10 or 100 Mbps activity is occurring
D/C (Duplex/Collision)	Green	The port is operating at full-duplex
	Amber	The port is operating at half-duplex
	Flashing amber	Collisions are occurring

**Table 15: LEDs on 8-port 1000BASE Fibre Line Cards<sup>1</sup>.**

LED	State	Function
L/A (Link/Activity)	Green	A 1000 Mbps link is open
	Flashing green	Link activity is occurring
	Amber	The L/A LED for port 1 briefly lights at switch power up or when the card is hot swapped in
D/C (Duplex/Collision)	Green	The port is operating at full-duplex
	Amber	The port is operating at half-duplex
	Flashing	Collisions are occurring

1. Includes LEDs on the following models:  
 AT-SB4451 8-port 1000BASE-SX (SC)  
 AT-SB4452 8-port 1000BASE-SX (MT-RJ)  
 AT-SB4461 8-port 1000BASE-LX (SC)  
 AT-SB4462 8-port 1000BASE-LX (MT-RJ)

On the AT-SB-L48, one green LED is provided for each port. The default is for the LED to show link (L/A) activity. Duplex/Collision activity (D/C) is shown while the LED Mode button (on the line card's face-plate) is pressed and held.

**Table 16: LEDs on the AT-SB4311 48-port 10/100BASE (RJ-45) Line Card.**

LED	State	Function
L/A (Default)	Green	A 100 Mbps link is open
	Flashing green	100 Mbps activity is occurring
	Amber	A 10 Mbps link is open. The L/A LEDs for ports 1 and 25 briefly light at switch power up or when the card is hot swapped in
	Flashing amber	10 Mbps activity is occurring
D/C (LED Mode button pressed)	Green	The port is operating at full-duplex
	Amber	The port is operating at half-duplex
	Flashing amber	Collisions are occurring

**Table 17: LEDs on the AT-SB4352 32-port 100BASE-FX (MT-RJ) Line Card.**

LED	State	Function
L/A (Link/Activity)	Green	A 100 Mbps link is open
	Flashing Green	100 Mbps activity is occurring
	Amber	The L/A LEDs for ports 1 and 17 briefly light at switch power up or when the card is hot swapped in
D/C (Duplex/Collision)	Green	The port is operating at full-duplex
	Amber	The port is operating at half-duplex
	Flashing Amber	Collisions are occurring

**Table 18: LEDs on the AT-SB4441 8-port 1000BASE GBIC Line Card.**

LED	State	Function
L/A (Link/Activity)	Green	A link is open
	Flashing Green	Activity is occurring
	Amber	The port is operating at half-duplex. The L/A LED for port 1 briefly lights at switch power up or when the card is hot swapped in
	Flashing Amber	Half-duplex activity is occurring
	Off	No link is present

**Table 18: LEDs on the AT-SB4441 8-port 1000BASE GBIC Line Card. (Continued)**

LED	State	Function
GBIC Status	Green	A GBIC is installed and enabled
	Amber	A GBIC is installed but disabled
	Flashing Amber	A fault is occurring on the link
	Off	No GBIC is installed

## Power Supply LEDs

Each PSU has the following LEDs.

**Table: 19 LEDs on AC and DC variants of the AT-SB4161 PSU .**

LED	State	Function
DC Good	Green	The PSU is supplying power to the switch
Fan Good	Green	The PSU's fan is functioning
Power Present	Green	The PSU is receiving power from its supply circuit.

## Check these first

1. Check the power cord(s) connection(s).
2. Check that the power supply voltage is stable.
3. Check that the correct data cables are being used and that their connections are secure.
4. Make sure that other network devices are working properly.
5. Use the `SHOW INSTALL` command to check that the latest software release is loaded. See the *SwitchBlade Software Reference* for more information about obtaining the latest software release.
6. If the switch is malfunctioning, reboot it by pressing the recessed Reset button or entering the command `RESTART REBOOT`. Alternatively, use the standby switch on the chassis's rear panel to power OFF and ON the switch.

## Some common problems and how to solve them

### Link/Activity LED on any port is off

This can indicate:

- A loose data cable.
- The device at the other end of the connection is not working properly or is turned off.
- The data cable is not wired correctly.
- The network administrator has manually disabled the port through the software.

- The port's selected transmission mode does not match that of the attached device.

Perform the following steps in sequence:

1. Make sure the data cable connections are secure.
2. Make sure the device at the other end of the connection is switched on and working properly.
3. Check that the data cable is wired correctly.
4. If you can, log in and check the port status. See "To log In" on page 28 for more information on how to log in.
5. If the port is Enabled, make sure the transmission speed matches that of the connected device (auto-negotiating, full or half-duplex).



---

*If the port is disabled, someone has used the software to manually disable it. You should find out why the port was disabled before enabling it.*

---

### Power LED is off

This can indicate:

- A loose power cord.
- A power supply failure.

Perform the following steps in sequence:

1. Check that the power cord connections are secure.
2. Check that all switches and circuit protection devices are in the ON position.
3. Ensure that the supply voltage is within the operational range for your particular chassis type and power supply. Refer to the section, "Physical and Operating Specifications" on page 9 of this manual.

### Fault LED is on

This can indicate:

- There is a problem with the switch or PSU.
- The switch or management software is malfunctioning.
- A hardware fault is preventing switch start-up.

Perform the following steps in sequence:

1. Check "LEDs and What They Mean" on page 40 for descriptions and explanations of LED flashing sequences.
2. Reset the switch by pressing the recessed RESET button on the front panel.
3. If you were attempting to download software or manage the switch via the RS-232 Terminal Port, check that connections between the Terminal Port and local terminal or PC are secure.

If you cannot access the switch's software because of a faulty RS-232 Terminal Port connection, you can still manage the switch via Telnet or SNMP until the problem is fixed.

4. Remove the switch controller from the chassis and then re-insert it.
5. Download the latest software release. See the *SwitchBlade Software Reference* for more information on how to obtain the latest software release.

## Expansion Options

---

This section provides a brief overview of the expansion options for the SwitchBlade. Contact your Authorised Allied Telesyn distributor or reseller for more information on these products, or visit our Web site at, [www.alliedtelesyn.co.nz/support/switchblade/](http://www.alliedtelesyn.co.nz/support/switchblade/).

### Content Addressable Memory (CAM)

CAM is an adaptation of random access memory (RAM) specifically designed to produce extremely fast look up times. Unlike conventional forms of RAM whose data content is accessed by referring to specific addresses, CAM operates by using the content data as addresses. Stored in each CAM location may be either the required data entity, or an address (in RAM) where it can be found.

Typically, the content data might be a table of Ethernet addresses and the required data entities could be either the switch ports to forward each frame to, or a RAM address where the forwarding port information can be found. The fast lookup times are achieved because, for each lookup, the entire contents of the CAM is simultaneously accessed and compared (within the hardware logic circuitry) with the reference data - a MAC address, for example.

There is a component of CAM located on each controller and line card. This can be extended - on all controller cards and on some line cards - by adding an appropriate extension card. The following sections explain this in more detail.

#### Switch Controller Card CAM

The switch controller card (SB4211) contains two CAM processor chips. Each chip contains 8 k entries of content addressable memory (CAM). These entries contain address locations for the forwarding database of L2/3 addresses and other similar entries such as VLAN identities. Located alongside each processor chip are 3 CAM chips that together provide an additional 96 k entries. Each processor chipset therefore, contains a total of 104 k entries of on-card CAM.

To extend this memory, two plug in CAM extender cards can be added to each switch controller card - one for each processor chipset. *Note that this extender card is sometimes referred to simply as "switchCAM."* Each extender card provides an additional 128 k entries, bringing the total CAM to 232 k entries per chipset.

Because each controller card has two processor chips, each containing its own forwarding database, two switchCAM extender cards are required when upgrading each switch controller card - in order to maintain balanced database sizes. Also, where a chassis contains two controller cards, their database sizes must be identical. Therefore, a SwitchBlade chassis containing two controller cards will require a total of 4 switchCAM extension cards (two for each switch controller card).

SwitchCAM cards can be ordered as a pre-installed items when purchasing switch controllers, or can be purchased separately when required.

#### Line Card CAM

Each line card comes with a basic 40 k entries of CAM per switch processor chip. These entries contain address locations for the forwarding database of

L2/3 addresses and other similar entries such as VLAN identities. Each switch chip contains 8 k entries of content addressable memory (CAM). Located alongside each switch chip is a CAM chip that provides an additional 32 k of CAM entries, thus producing a total of 40 k entries per on-card chipset.

To extend the lineCAM beyond the basic 40 K, a lineCAM extender card can be added to certain line cards. *Note that this extender card is sometimes referred to simply as "lineCAM."* Each lineCAM extender card comprises 6 CAM chips that together provide an additional 192 k entries of additional line card CAM. Therefore a line card with the lineCAM extender card installed, provides a total of 232 k of CAM entries per line card chipset.

One LineCAM extender card can be installed on each of the following line cards:

- AT-SB4411 8-port 10BASE-T/100BASE-TX/1000BASE-T (RJ-45) Line Card
- AT-SB4441 8-port 1000BASE-X (GBIC) Line Card
- AT-SB4451 8-port 1000BASE-SX (SC) Line Card
- AT-SB4461 8-port 1000BASE-LX (SC) Line Card
- AT-SB4452 8-port 1000BASE-SX (MT-RJ) Line Card
- AT-SB4462 8-port 1000BASE-LX (MT-RJ) Line Card

Refer to the card descriptions shown in the *"Physical and Operating Specifications"* on page 9 for more information on the above line cards.



*LineCAM can also be installed in AT-9800 series switches.*

LineCAM is available as a 192 k-entry module. LineCAM can be ordered as a pre-installed item when purchasing line cards, or can be purchased separately and installed as needed.

To check how much CAM is installed, enter

```
SHOW SWITCH
```

Figure 11 on page 50 shows an example output display from this command.

## Installing CAM

SwitchCAM and LineCAM are not interchangeable. SwitchCAM can only be used with switch controllers, and LineCAM can only be used with the line cards listed in the previous Line Card CAM section.

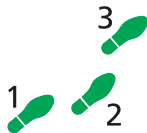

### To install Switch or LineCAM

1. **Check that you have the correct tools and equipment available.**

If the switch controller or line card is already installed in a chassis, you will need a Phillips #2 screwdriver, to remove the controller or card.

2. **Avoid injury by working in a safe environment.**

The workspace should be free of hazards, and there should be sufficient room to lay out the switch controller, CAM, and tools.

3. **Unpack the CAM in an antistatic environment.**



---

*Do not attempt to install any hardware without observing correct antistatic procedures. Failure to do so may damage the switch controller, line card, or CAM. If you are unsure what the correct procedures are, contact your authorised Allied Telesyn distributor or reseller.*

---

#### **4. Remove the switch controller or card.**

If the switch controller or line card is installed in a chassis, disconnect any management or network cables and remove the controller or card.

Switch controllers and line cards can be hot swapped. See the *Switch Controller Quick Install Guide* and *Line Card Quick Install Guide* for more information.



---

*When upgrading CAM on a SwitchBlade system that includes two switch controllers, both controllers must be upgraded at the same time. Each switch controller requires two CAM modules for the upgrade.*

---

#### **5. Align the CAM.**

Position the CAM card over the CAM slot(s) on the switch controller or line card. The support pillars located on the board should be aligned with the holes on the CAM card, and the its chamfers should be orientated as shown in Figure 9 on page 48 and Figure 10 on page 48.

#### **6. Insert the CAM.**

Press the CAM card firmly into place. Secure the CAM card to its pillars using the supplied screws. The switchCAM card uses two mounting pillars, while lineCAM card uses three mounting pillars.

If installing a CAM card in a switch controller, repeat the process for both CAM slots.

Figure 9: Location of CAM slot and pillar mounts on an SB4211 switch controller.

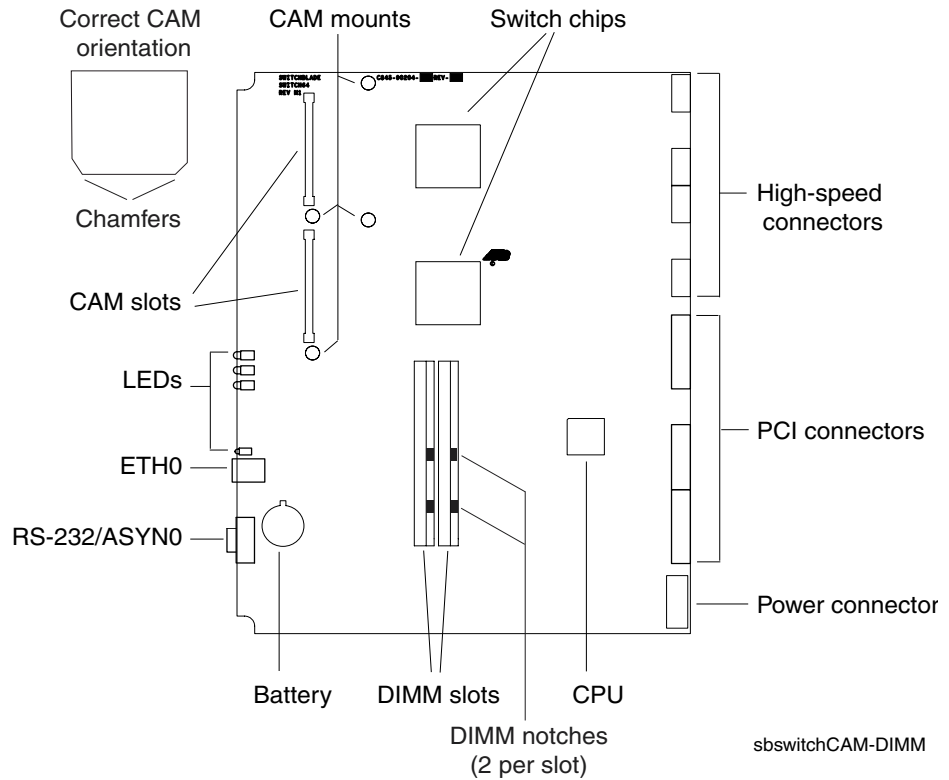
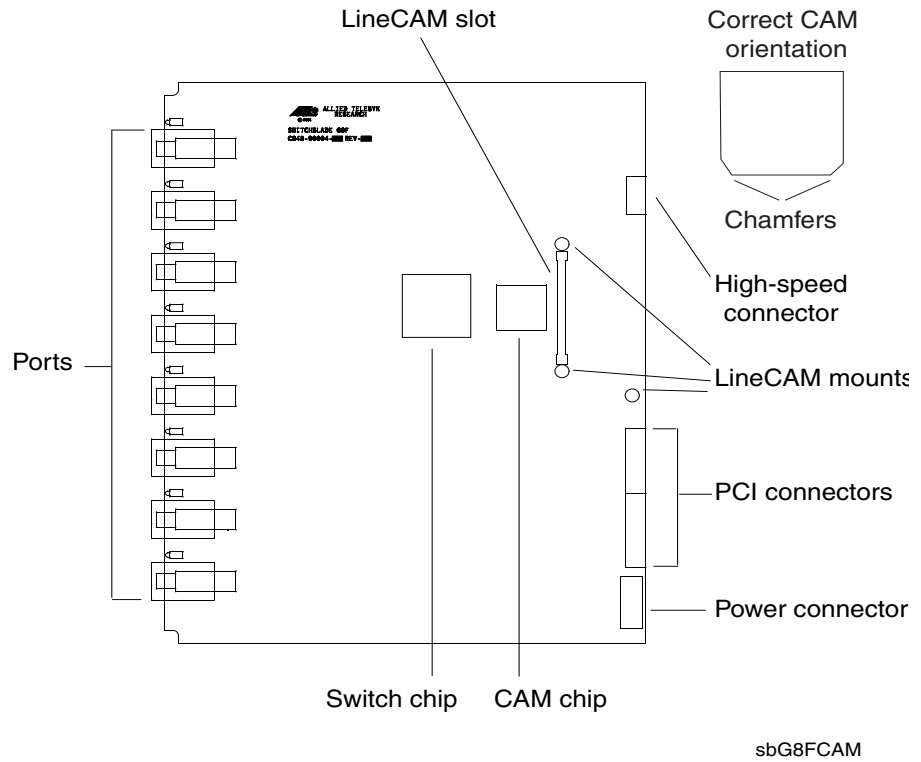

Figure 10: Location of CAM slot and pillar mounts on SB4411 8-port 10/100/1000 (RJ-45) and AT-SB4451 8-port 1000BASE-SX (SC) Line Cards.



7. Install the switch controller or line card.

Insert the switch controller or line card into a chassis.

See the *Switch Controller Quick Install Guide* and *Line Card Quick Install Guide* for more information.

#### 8. Connect management and network cables.

Reconnect any management or network cables you disconnected to install the CAM, or connect any new cables.

The CAM is now ready to test.

## Testing the CAM Card

To check that the switch has recognised the (now extended) CAM, turn on the switch and enter the command:

```
SHOW SWITCH
```

to display system information (Figure 11 on page 50), including the amount of CAM installed on each switch controller card and line card.

If there is no entry for the CAM, or the entry displays an unexpected value, then the switch has not correctly detected the CAM's presence. The most likely cause is that the CAM is not correctly plugged into the slot on the switch controller or line card. Repeat the installation process, paying particular attention to the CAM alignment and insertion steps.

Use the SHOW SWITCH command again, and if the display is still not correct, contact your authorised Allied Telesyn distributor or reseller.

**Figure 11: Example output from the SHOW SWITCH command for a SwitchBlade with two switch controllers (both with upgraded CAM) and two line cards (one with upgraded CAM).**

```

Switch Configuration
-----
Switch Type ..... Master
Blade Position ..... 9
Blade Switch Instance ..... 0
IP Address ..... 192.168.255.0
IPX Address ..... fffffff0
PCI errors ..... 0
CAM size ( entries ) ..... 237568
Switch Address ..... 00-00-cd-03-00-79
Learning ..... ON
Ageing Timer ..... ON
Number of Fixed Ports ..... 0
Number of Uplink Ports ..... 0
Mirroring ..... DISABLED
Mirror port ..... None
Ports mirroring on Rx ..... None
Ports mirroring on Tx ..... None
Ports mirroring on Both .... None
Number of WAN Interfaces ... 0
Name of Interface(s) ..... -
Ageingtime ..... 300
VLAN classification ..... To be defined
UpTime ..... 00:01:31
-----

Switch Configuration
-----
Switch Type ..... Master
Blade Position ..... 9
Blade Switch Instance ..... 1
IP Address ..... 192.168.255.0
IPX Address ..... fffffff0
PCI errors ..... 0
CAM size ( entries ) ..... 237568
Switch Address ..... 00-00-cd-03-00-79
Learning ..... ON
Ageing Timer ..... ON
Number of Fixed Ports ..... 0
Number of Uplink Ports ..... 0
Mirroring ..... DISABLED
Mirror port ..... None
Ports mirroring on Rx ..... None
Ports mirroring on Tx ..... None
Ports mirroring on Both .... None
Number of WAN Interfaces ... 0
Name of Interface(s) ..... -
Ageingtime ..... 300
VLAN classification ..... To be defined
UpTime ..... 00:01:31
-----

```

**Figure 11: Example output from the SHOW SWITCH command for a SwitchBlade with two switch controllers (both with upgraded CAM) and two line cards (one with upgraded CAM). (Continued)**

```

Switch Configuration
-----
Switch Type ..... Slave
Slave Card Type ..... Line 8
Blade Position ..... 5
Blade Switch Instance ..... 0
IP Address ..... 192.168.255.0
IPX Address ..... ffffff00
PCI errors ..... 0
CAM size ( entries ) ..... 40960
Switch Address ..... 00-00-cd-03-00-79
Learning ..... ON
Ageing Timer ..... ON
Number of Fixed Ports ..... 8
Number of Uplink Ports ..... 0
Mirroring ..... DISABLED
Mirror port ..... None
Ports mirroring on Rx ..... None
Ports mirroring on Tx ..... None
Ports mirroring on Both .... None
Number of WAN Interfaces ... 0
Name of Interface(s) ..... -
Ageingtime ..... 300
VLAN classification ..... To be defined
UpTime ..... 00:01:31
-----

Switch Configuration
-----
Switch Type ..... Slave
Slave Card Type ..... Line 8
Blade Position ..... 8
Blade Switch Instance ..... 0
IP Address ..... 192.168.255.0
IPX Address ..... ffffff00
PCI errors ..... 0
CAM size ( entries ) ..... 237568
Switch Address ..... 00-00-cd-03-00-79
Learning ..... ON
Ageing Timer ..... ON
Number of Fixed Ports ..... 8
Number of Uplink Ports ..... 0
Mirroring ..... DISABLED
Mirror port ..... None
Ports mirroring on Rx ..... None
Ports mirroring on Tx ..... None
Ports mirroring on Both .... None
Number of WAN Interfaces ... 0
Name of Interface(s) ..... -
Ageingtime ..... 300
VLAN classification ..... To be defined
UpTime ..... 00:01:31
-----

```



*If any CAM test fails, check that the CAM is correctly installed in its slot and repeat the tests. Contact your authorised Allied Telesyn distributor or reseller if the CAM does not operate correctly.*

## Dual In-line Memory Modules (DIMMs)

RAM for SwitchBlade switch controllers is provided in the form of two 128 MByte DIMMs. The two DIMMs deliver 256 MBytes of Synchronous DRAM.

To minimise the risk of damage during shipment, DIMMs are not installed on switch controllers at the factory. Instead, the two 128 MByte DIMMs are included in a CPU memory pack, which ships with each switch controller.

### Installing DIMM

AT-SB4211 switch controllers have two DIMM slots. Both of these slots must be populated with a 128 MByte DIMM before the switch controller can be used.



*Only Allied Telesyn supplied DIMMs have been tested and approved for use with SwitchBlade switch controllers. Using DIMM that has not been approved may cause unreliable operation and will invalidate the switch controller's warranty.*

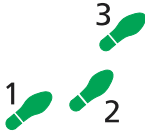

#### To install a DIMM

##### 1. Prepare the switch controller.

If the switch controller is installed in a chassis, remove it by following the instructions in the *SwitchBlade Switch Controller Quick Install Guide*. The quick install guide can be found on the CD-ROM shipped with each switch controller and chassis, and can be downloaded from [www.alliedtelesyn.co.nz/support/switchblade/](http://www.alliedtelesyn.co.nz/support/switchblade/).

Lay the switch controller on a flat surface.

##### 2. Prepare the DIMMs.

In an antistatic environment, remove the two DIMMs from their packing material. Be sure to observe ESD precautions.



*Do not attempt to install DIMM without observing correct antistatic procedures. Failure to do so may damage the DIMM and switch controller. If you are unsure what the correct procedures are, contact your authorised Allied Telesyn distributor or reseller.*



*A chassis ground socket is provided on the front vent panel of the SwitchBlade chassis. This socket is designed to be used in conjunction with an ESD wrist strap.*

##### 3. To remove an existing DIMM.

Each DIMM is held in place by two retaining latches, one latch at each end of the DIMM slot. Release these latches and carefully pull the DIMM from the DIMM slot.

The location of DIMM slots is shown in Figure 12 on page 53.

##### 4. Align and insert the first DIMM.

Holding a DIMM at an angle of about 30 degrees from horizontal, align the notches on its connector strips with the notches on an empty DIMM slot (see Figure 12 on page 53).

Insert the DIMM into the DIMM slot, sliding it along the two DIMM guides until the retaining latches automatically click into place. The latches should hold the DIMM firmly in place.

#### 5. Insert the second DIMM.

Repeat Step 4 for the second DIMM.





---

*For the switch to function, both DIMMs must be installed (giving 256 MBytes of DRAM per switch controller).*

---

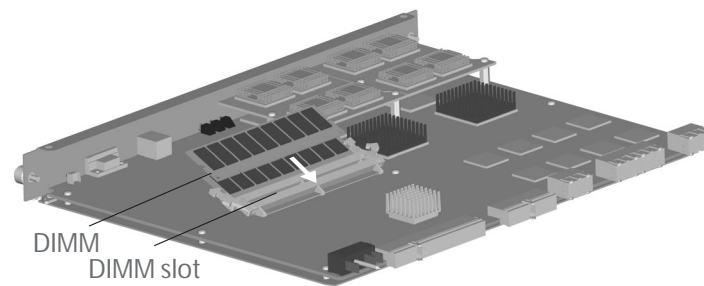
**Figure 12: Installing DIMM on the AT-SB4211 Switch Controller.**



## Testing DIMM

The switch is unlikely to boot unless the DIMM is correctly installed. The switch controller's fault LED will flash slowly if the DIMM is not detected. The fault LED will flash quickly if the DIMM is not of an acceptable type.

If the switch does boot but you suspect the DIMM is malfunctioning, or if you have swapped in a switch controller with new DIMM, enter the command:

```
SHOW SYSTEM
```

to display the system information shown in Figure 13 on page 54. In the output's memory section there should be an entry showing the size of DRAM. If the DRAM size is less than the size of DIMM that has been installed, then the switch has not correctly detected the DIMM. The most likely cause is that the DIMM connector is not plugged into its slot correctly. Repeat the installation process, paying particular attention to the DIMM insertion step.

After repeating the installation, use the SHOW SYSTEM command again, and if the display is still not correct, contact your authorised Allied Telesyn distributor or reseller.



---

*If you have any difficulty with the DIMM at any time, contact your authorised Allied Telesyn distributor or reseller and quote the serial numbers of both the base card on the switch controller and the DIMM. The switch controller's serial numbers and revision details can be read using the SHOW SYSTEM command. It's a good idea to record this information for later reference.*

---

**Figure 13: Example output from the SHOW SYSTEM command for a switch controller with DIMM installed.**

```

Switch System Status                               Time 10:17:43 Date
07-Feb-2002.
Board      ID   Bay Board Name                               Rev   Serial number
-----
Base      164      AT-SB4211                               M1-0  50433214
Chassis   160      AT-SB4108-00                            M1-0  41987310
Blade     171     5  AT-SB4411                               M2-0  41362530
-----
Memory -   DRAM :262144 kB   FLASH : 32768 kB
-----
SysDescription
Allied Telesyn AT-SB4211 version 2.4.0-00 22-Aug-2001
SysContact

SysLocation

SysName

SysDistName

SysUpTime
8472 ( 00:01:24 )
Software Version: 2.4.0-00 22-Aug-2001
Release Version : 2.4.0-00 22-Aug-2001
Release built   : Feb 7 2002 at 02:08:26
Patch Installed : NONE
Territory      : usa
Help File      : help.hlp

Configuration
Boot configuration file: Not set
Current configuration: Not set

Security Mode   : Disabled

Warning (2048283): No patches found.

```

## Gigabit Interface Converters (GBICs)

The AT-SB4441 line card provides slots for eight GBICs. GBICs are removable gigabit port converters, and allow users to add and remove port types to meet changing network requirements. RJ-45 copper, and SC and LC fibre GBICs are currently available. GBICs can be purchased when an AT-SB4441 line card is purchased, or can be ordered separately as needed.

Only tested and approved 5V Ethernet GBICs should be used with the AT-SB4441.



*A range of GBICs have been tested and approved for use with the SwitchBlade, contact your authorised Allied Telesyn distributor or reseller for more information, or visit [www.alliedtelesyn.co.nz](http://www.alliedtelesyn.co.nz).*



*RX and TX terminal locations on SC fibre GBIC ports are the reverse of TX and RX terminal locations on fixed SC fibre ports. When looking at an SC fibre GBIC from the front, the RX terminal is on the left and the TX terminal is on the right.*

## GBIC 1000BASE-T Auto-Negotiation

1000BASE-T GBICs support only 1000 Mbps full-duplex connections. Although 1000BASE-T GBICs will participate in auto-negotiation processes, they will only advertise 1000 Mbps. Half duplex, 10BASE-T, and 100BASE-TX modes are not supported.

While 1000BASE-T GBICs will auto-negotiate at the copper Ethernet level, the ports will behave as if in fixed 1000 Mbps full-duplex mode. This is because the SERDES connection used by GBIC ports makes the auto-negotiation invisible to the switch, and so prevents a successful link negotiation.

When a 1000BASE-T GBIC is inserted into a GBIC slot, the port's auto-negotiation capability is disabled. This means that the port speed may not be set to *auto-negotiate*. If the port had been configured to auto-negotiate (by default or by command) prior to the GBIC's insertion, then this configuration is overridden for as long as the GBIC remains in place.

## Port, Connector, and Cable Combinations

This section provides cabling guidelines for each line card model.

**Table 20: Cable guidelines for line cards.**

Model	Port Type	Connector Type	Cable Type <sup>1</sup>	Maximum Cable Length
AT-SB4311 Line Card	10BASE-T/100BASE-TX	RJ-45	10BASE-T Category 3 or better	100m (328ft)
			100BASE-TX Category 5 or better	100m (328ft)
AT-SB4352 line card	100BASE-FX	MT-RJ	50/125 or 62.5/125 micron multimode fibre	Full-duplex 2km (6,600ft) Half-duplex 412m (1360ft)
AT-SB4411 Line Card	10BASE-T/100BASE-TX/ 1000BASE-T	RJ-45	CAT5	100 to 150m (328 to 492ft)
			CAT5E	200m (656ft)
AT-SB4412 Line Card	10BASE-T/100BASE-TX/ 1000BASE-T	RJ-45	CAT5	100 to 150m (328 to 492ft)
			CAT5E	200m (656ft)
AT-SB4441 Line Card	1000BASE-X	Varies with GBIC	Refer to GBIC's user documentation	Refer to GBIC's user documentation
AT-SB4451 Line Card	1000BASE-SX	SC	50/125 micron multimode fibre	550m (1,804ft) <sup>2</sup>
			62.5/125 micron multimode fibre	275m (902ft) <sup>3</sup>

Table 20: Cable guidelines for line cards. (Continued)

Model	Port Type	Connector Type	Cable Type <sup>1</sup>	Maximum Cable Length
AT-SB4452 Line Card	1000BASE-SX	MT-RJ	50/125 micron multimode fibre	550m (1,804ft) <sup>2</sup>
			62.5/125 micron multimode fibre	275m (902ft) <sup>3</sup>
AT-SB4461 Line Card	1000BASE-LX	SC	9/125 micron singlemode fibre	3km (1.8mi) Increasing to 10km (6mi) if linking two 1000BASE-LX models
			50/125 or 62.5/125 micron multimode fibre	550m (1804ft) <sup>2</sup>
AT-SB4462 Line Card	1000BASE-LX	MT-RJ	9/125 micron singlemode fibre	3km (1.8mi) Increasing to 10km (6mi) if linking two 1000BASE-LX models
			50/125 or 62.5/125 micron multimode fibre	550m (1804ft) <sup>2</sup>

1. Refer to the IEEE 802.3 standards for further cable information.

2. Assumes a fibre optic cable rating of 500 Mhz/Km. (Maximum cable length is 500m at a cable rating of 400 Mhz/Km.)

3. Assumes a fibre optic cable rating of 200 Mhz/Km. (Maximum cable length is 220m at a cable rating of 160 Mhz/Km.)

## Using Windows Terminal and Windows Hyperterminal

You can use a PC running terminal emulation software as the manager console, instead of a terminal. There are many terminal emulation applications available for PCs, but the most readily available are the Terminal and HyperTerminal applications included in Microsoft Windows 95, 98, 2000, and Windows NT 4.0. In standard Windows installations, HyperTerminal is located in the Start > Programs > Accessories menu.

The key to successful use of terminal emulation software with the switch is to configure the software and switch with matching communications parameters. The following procedures describe how to configure Windows Terminal and HyperTerminal for the default ASYN0 settings on the switch controller, but the same principles apply to other terminal emulation programs.

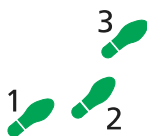

### To configure Windows HyperTerminal for Windows 95, 98, 2000, & NT 4.0

#### 1. In Windows, select:

- Programs > Accessories > HyperTerminal.
- Double-click the Hypertrm.exe icon.

#### 2. In the Connection Description dialog box:

- Enter a name for the connection (e.g., SwitchBlade1)
- Select an icon from the scrolling list.
- Click "OK".

**3. In the Phone Number dialog box:**

From the “Connect using:” drop-down list, select:

- “Direct to Com *n*” Where “COM *n*” is the COM port on the PC used to connect to the switch.
- Click “OK”.

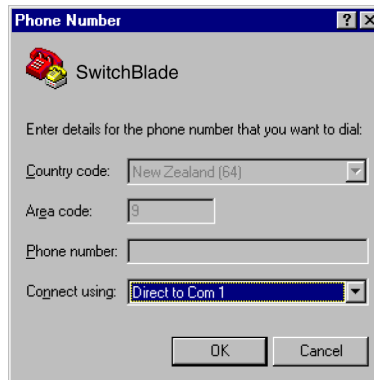
**4. In the COMn Properties dialog box, set:**

- Bits per second: 9600.
- Data bits: 8.
- Parity: None.
- Stop bits: 1.
- Flow control: Hardware.
- Click “OK”.

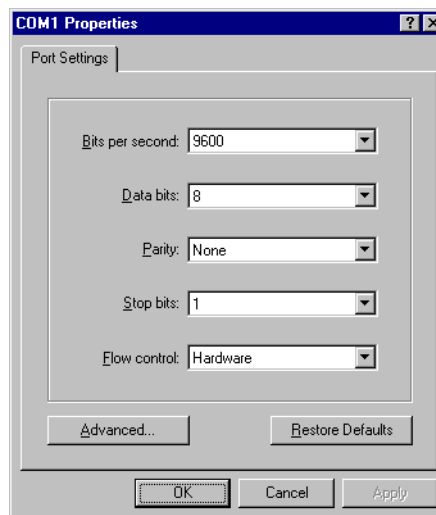
**5. From the File menu, select:**

- “Properties”

In the Connection Properties dialog box, click the Settings tab and set:

- “Function, arrow, and ctrl keys act as” to “Terminal keys”
- “Emulation” to VT100.

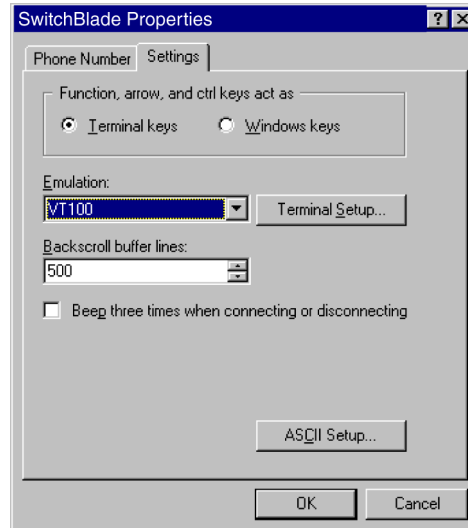

6. Click "ASCII Setup" to display the ASCII Setup dialog box. Uncheck:

- "Echo typed characters locally".
- "Append line feeds to incoming line ends".

Set other parameters as required.

- Click "OK" twice to close all dialog boxes.

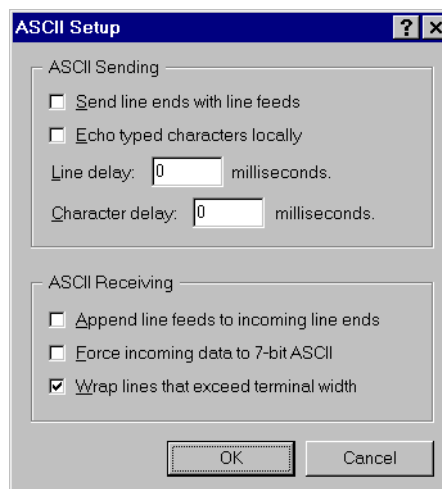

7. Save the current session. From the File menu, select:

- "Save".

This creates a connection icon with the name you assigned in the HyperTerminal group. To use the configuration:

- Double-click the connection icon in the HyperTerminal group.

When the HyperTerminal window appears, press:

- [Enter] a couple of times.

The switch's log in prompt will appear.

## Restricted Procedures

This section contains procedures that should only be performed by authorised service personnel. Unauthorised use of procedures in this section may cause danger of injury from electric shock, damage to the switch, and invalidation of the product warranty.

If you would like to know more about the procedures outlined in this section, please contact your authorised Allied Telesyn distributor or reseller.

### Diagnostics

The switch software includes a set of diagnostic programs. These programs perform basic level checks of all system components. They do not run in conjunction with the normal operating code, and require that the system be totally dedicated to their use. A detailed knowledge of the way the switch hardware functions is necessary if diagnostics are to be used effectively.



---

*The switch will not perform switching operations if diagnostics are running.*

---



---

*This section is not intended as a guide to the diagnostics software. Diagnostics are designed to be run by service personnel only. For more information, contact your Authorised Allied Telesyn distributor or reseller.*

---

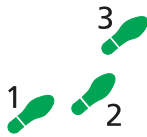

#### To enable diagnostics mode

**1. Connect a terminal to the RS-232 Terminal Port (ASYN0).**

Using a terminal cable, connect a terminal to RS-232 (ASYN0) on the master switch controller. See “Useful Cables” on page 34 for more information on terminal cables.

Set the terminal communication parameters to the following:

- Baud rate: 9600
- Data bits: 8
- Parity: None
- Stop bits: 1
- Flow control: Hardware

**2. Restart the switch.**

Restart the switch, either by using a pen or pencil to operate the recessed reset button on the switch controller’s front panel, or by using the terminal to log in and enter the command:

```
RESTART REBOOT
```

See “To log In” on page 28 for more information on how to log in.

**3. Enable diagnostics mode during start-up.**

During the switch start-up process, at the prompt:

```
Force EPROM download (Y)?
```

press [Ctrl/D] on the terminal to enter diagnostics mode. A banner page will be displayed on the terminal (Figure 14 on page 60). This can be used to check that the terminal is correctly connected.



**Performing a Full Flash Test or erasing flash will delete all configuration and release files. Make sure you know how to reload these files before erasing flash or performing a flash test.**

**Figure 14: SwitchBlade diagnostics banner page.**

```
* * * Diagnostic Mode * * *

version 16-Mar-98

Main Menu:
 0. Restart
 1. Full RAM test
 2. ROM checksum test
 3. Full FLASH test
 4. Totally Erase FLASH
 5. Battery backed RAM test
Enter selection ==>
```

To run a diagnostic program, enter the corresponding letter or number (or key). There are several sub-menus to cover all the available options. Table 21 on page 60 lists the control keys for diagnostic operations.

**Table 21: Basic commands for running the diagnostics.**

Key	Function
Q	Quits any running tests and displays the banner page.
S	Prints a summary of test results so far.

A reasonable understanding of the system's structure is needed to operate diagnostics and interpret the results.

To restore the switch to normal operation, use a pen or pencil to operate the recessed reset button on the front panel, or press "0" (zero) to restart.

## Contacting Us

With locations covering all of the established markets in North America, Latin America and Europe, Allied Telesyn provides localized sales and technical support worldwide. To find our representative nearest you, visit Allied Telesyn on the web at: <http://www.alliedtelesyn.com>.