

# Uplink Module Installation and Safety Guide



AT-A35/SX  
AT-A35/LX  
AT-A39/T  
AT-A40/SC  
AT-A40/MT  
AT-A41/SC  
AT-A41/MT  
AT-A42/GBIC

Uplink Module Installation and Safety Guide  
Document Number 613-000689 Rev A.

Copyright © 2006 Allied Telesis Inc. All rights reserved. No part of this publication may be reproduced without prior written permission from Allied Telesis, Inc.

Allied Telesis, Inc. reserves the right to make changes in specifications and other information contained in this document without prior written notice. The information provided herein is subject to change without notice. In no event shall Allied Telesis, Inc. be liable for any incidental, special, indirect, or consequential damages whatsoever, including but not limited to lost profits, arising out of or related to this manual or the information contained herein, even if Allied Telesis has been advised of, known, or should have known, the possibility of such damages.

All company names, logos, and product designs that are trademarks or registered trademarks are the property of their respective owners.

## Package Contents

---

The following items are included with each uplink module. Contact your authorised Allied Telesis distributor or reseller if any items are damaged or missing.

- One uplink module.
- One *Uplink Module Installation and Safety Guide*.
- One warranty card.

## Compatible Switches

---



**Caution** Attempting to install an expansion module into a switch which is not compatible may damage the switch and the expansion module. Compatible expansion modules are listed in your switch's Hardware Reference. If you are unsure of a module's compatibility, contact an authorised Allied Telesis distributor or reseller.

The following uplink modules are compatible with all Rapier switches, Rapier *i* switches, AT-8700XL switches and AT800 modular switching routers:

- AT-A35/SX
- AT-A35/LX
- AT-A39/T
- AT-A42/GBIC

The following uplink modules are compatible with Rapier G6 and G6F switches, all Rapier *i* switches and all AT-8700XL switches:

- AT-A40/SC
- AT-A40/MT
- AT-A41/SC
- AT-A41/MT

## Installing an Uplink Module

---

Follow these steps to install an uplink module into a switch or switching router:

### I. Read the safety information.

For safety information, see the *Safety and Statutory Information* booklet for your switch. A copy of this booklet is supplied with each switch, and can also be downloaded from [www.alliedtelesis.com/support/](http://www.alliedtelesis.com/support/).

## 2. Gather the tools and equipment you will need.

A medium-sized flat-bladed screwdriver may be useful when loosening the uplink module thumbscrews. You should also have any cables required for connecting the uplink module to other network devices.

AT-A42/GBIC uplink modules require a GBIC before they can be connected to a network.

## 3. Remove power to the switch or router.



**Warning** Do not install an uplink module into a switch without first removing power from the switch. Be sure to disconnect both the main power supply and any attached redundant power supply. Installing an uplink module with the switch powered ON can damage the module and the switch.

The power cord and the redundant power supply cable are used to disconnect AC switches. To de-energize the equipment, disconnect the power cord and the redundant power supply cable.

## 4. Remove the appropriate uplink bay face-plate on the switch's front panel.

Remove the appropriate face-plate as shown in the following figure. If your switch has multiple uplink bays, and no uplink modules are currently installed, then install the uplink module into the switch's top bay. This simplifies VLAN configuration.

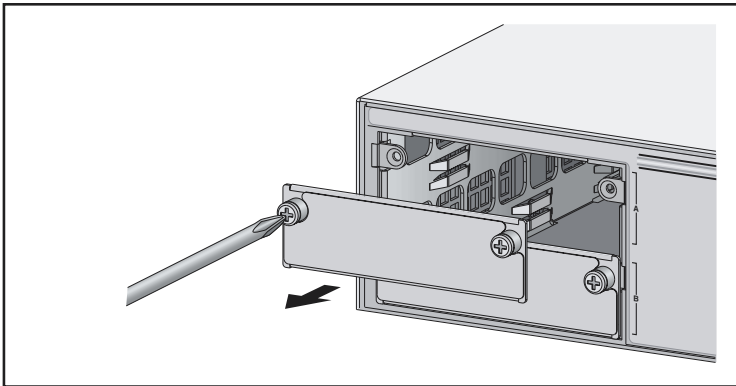

Keep the face-plate for future use. If you should remove the uplink module, replace the face-plate to prevent dust and debris from entering the switch and to maintain proper airflow.

### 5. Prepare the uplink module.

In an antistatic environment, remove the uplink module from its packing material. Be sure to observe ESD precautions.



**Warning** Do not attempt to install an uplink module or any other expansion option without observing correct antistatic procedures. Failure to do so may damage the switch or uplink module. If you are unsure what the correct procedures are, contact your authorised Allied Telesis distributor or reseller.

### 6. Slide the uplink module into place.

Make sure the module is aligned with the card guides on each side of the bay (see the following figure).

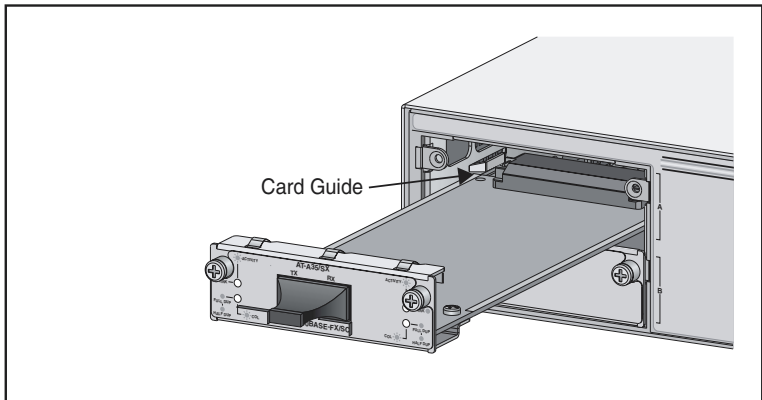

### 7. Secure the uplink module to the switch.

Firmly press the uplink module until its connectors engage the uplink bay connectors inside the switch.

Use a screwdriver to tighten the uplink module's screws. Do not over-tighten the screws.

### 8. For AT-A42/GBIC uplink modules, install the GBIC.

Slide the GBIC into the uplink's GBIC slot. Press the GBIC firmly into place.

A range of GBICs have been tested and approved for use with AT-A42 uplink modules. Contact your authorised Allied Telesis distributor or reseller for more information, or visit [www.alliedtelesis.com](http://www.alliedtelesis.com).

RX and TX terminal locations on SC fibre GBIC ports are the reverse of TX and RX terminal locations on fixed SC fibre ports. When looking at an SC fibre GBIC from the front, the RX terminal is on the left and the TX terminal is on the right.

**9. Apply power to the switch.**

The switch's Fault LED may flash for approximately 10 seconds as it runs internal tests.

**10. Check that the Power LED on the switch's front panel lights green.**

If the LED fails to light, refer to the Troubleshooting section of the *Uplink Module Hardware Reference*.

**11. Connect the data cables.**

If fitted, remove the uplink module's port dust cover, and connect the data cable. Make sure each cable connection is secure.

**12. Check the uplink module's LEDs.**

Use the tables in "[Uplink Module LEDs](#)" to check the module's LEDs. Information on switch system and switch port LEDs can be found in the Troubleshooting section of the Hardware Reference for your switch.

## Uplink Module LEDs

---

### LEDs for the AT-A40/SC, AT-AR40/MT, AT-A41/SC and AT-AR41MT:

LED	State	Function
Activity/ Link/ Fault	Green	A link is established and the port is enabled.
	Flashing green	100 Mbps activity is occurring.
	Flashing amber (and lower LED is off)	The link has failed at the remote end.
	Off	No link is present.
Full Dup/ Half Dup/ Col	Green	The port is operating at full-duplex.
	Amber	The port is operating at half-duplex.
	Flashing amber	Collisions are occurring.
	Off	No link is present.
Both LEDs	Alternating amber flashing of upper and lower LED	The switch does not support this model of uplink module.

**LEDs for the AT-A42/GBIC:**

<b>LED</b>	<b>State</b>	<b>Function</b>
L/A Link/Activity	Green	A 1000 Mbps link is established.
	Flashing green	1000 Mbps activity is occurring.
	Flashing amber (and GBIC LED is off)	A transmission fault has occurred.
	Off	No link is present.
GBIC	Green	The switch has recognised the GBIC, the GBIC is a valid model.
	Green (and L/A LED is flashing green)	The port is operating at full-duplex.
	Amber (and L/A LED is off)	The switch has not recognised the GBIC, the GBIC is not a valid model.
	Amber (and L/A LED is off)	The port is operating at half-duplex.
	Flashing amber (and L/A LED is flashing green)	Collisions are occurring.
	Off	No GBIC is installed, or a transmission fault has occurred.
Both LEDs	Slow alternate flashing of L/A and GBIC LED, amber	The switch has not recognised the GBIC, or the GBIC is not a valid model.

**LEDs for the AT-A35/SX and AT-A35/LX:**

<b>LED</b>	<b>State</b>	<b>Function</b>
Link	Green	An optical signal is reaching the port.
	Off	No link is present.
Activity	Flashing Amber	The port is transmitting or receiving frames.
	Off	No activity is occurring.

## LEDs for the AT-A39/T:

LED	State	Function
Full Dup/ Half Dup/ Col	Green	The port is operating at full-duplex.
	Amber	The port is operating at half-duplex.
	Flashing amber	Collisions are occurring.
	Off	No link is present.
Activity	Green	A 1000 Mbps link is established.
	Flashing green	1000 Mbps activity is occurring.
	Amber <sup>a</sup>	A 10/100 Mbps link is established.
	Flashing amber	10/100 Mbps activity is occurring.
	Off	No link is present.

- a. 10/100/1000 Mbps operation is available only if the AT-A39/T is installed in a Rapier G6 or G6F, Rapier *i* or AT-8700XL model, otherwise operation is fixed at 1000 Mbps. Early versions of the AT-A39/T operate at 1000 Mbps only, regardless of the switch model.

## Where To Find More Information

For further details about your uplink module or your switch, see:

- The *Uplink Module Hardware Reference* for detailed information on uplink modules. This reference can be found on the CD-ROM bundled with your switch, or at [www.alliedtelesis.co.uk/site/products/](http://www.alliedtelesis.co.uk/site/products/).
- The Installation Guide and Hardware Reference for your switch. These contain detailed information on the operational requirements of each switch or network configuration.

For other switch and router expansion options, see:

- The *Network Service Module Installation and Safety Guide*, which outlines the procedure for installing an NSM; and the *Network Service Module Hardware Reference*, which provides detailed information on NSMs.
- The *Port Interface Card Installation and Safety Guide*, which outlines the procedure for installing a PIC; and the *Port Interface Card Hardware Reference*, which provides detailed information on PICs.
- You can find these documents on the Documentation and Tools CD-ROM bundled with each switch or router, or at [www.alliedtelesis.com](http://www.alliedtelesis.com).

