

## Chapter 30

# Time Division Multiplexing (TDM)

Introduction .....	30-2
E1/T1 Time Division Multiplexing .....	30-3
Static E1/T1 TDM Versus ISDN Calling .....	30-4
BRI Time Division Multiplexing .....	30-5
Configuration Examples .....	30-5
Configuring static E1/T1 TDM on a PRI .....	30-5
Configuring TDM on a BRI .....	30-7
Command Reference .....	30-7
ADD TDM .....	30-8
CREATE TDM .....	30-8
DELETE TDM .....	30-10
DESTROY TDM .....	30-10
PURGE TDM .....	30-11
SHOW TDM .....	30-11

## Introduction

---

This chapter describes the Time Division Multiplexing (TDM) support provided by the switch, and how to configure the switch to use E1/T1 TDM and BRI TDM.

Time division multiplexing is a mechanism for dividing the bandwidth of a link into separate channels or time slots. The switch supports TDM in two forms—E1/T1 TDM and BRI TDM. BRI and PRI interfaces are available as optional Port Interface Cards (PICs).

E1 TDM provides a 2.048Mbps communications link divided into 32 slots of 64kbps each. T1 TDM provides a 1.544Mbps communication link divided into 24 slots of 64kbps each and an 8kbps channel for synchronisation and maintenance. E1 and T1 TDM were first used by telephone companies for the transport of digitised voice, but since there is no difference between digitised voice and other kinds of data E1 and T1 TDM are now also used for wide area network links.

Of the 32 time slots in a E1 TDM link, time slot 0 is usually reserved for framing. For Primary Rate ISDN running over E1 where calls need to be set up and cleared dynamically, time slot 16 is reserved for signalling. This leaves up to 30 time slots, each of 64kbps, for information transfer over ISDN calls and up to 31 time slots for static TDM links. A mixture of static and dynamic ISDN calls is also possible. An E1 TDM link may also be used in an unstructured mode where all of the 2.048Mbps of bandwidth is available for data transfer. In this mode only a single link of the full bandwidth is possible and slot 0 is not used to demarcate the slot structure.

For T1 Primary Rate ISDN, time slot 24 is reserved for signalling and the other 23 time slots are available for ISDN calls. When the T1 interface is not used for ISDN, slot 24 may be used for a TDM link. Unstructured mode is not supported for T1 TDM.

E1/T1 TDM support is provided on the switch by the Primary Rate interface (PRI) card. The E1/T1 TDM facility can be used as the data link layer transport mechanism for Primary Rate ISDN and as the data channel over which one or more static PPP links can be configured. It is this later functionality which is described in this chapter. See *Chapter 10, Integrated Services Digital Network (ISDN)* for more information about using a Primary Rate interface for Primary Rate ISDN connections.

BRI TDM support is provided by a switch Basic Rate Interface which can be used for Basic Rate ISDN and as a data channel for one or more static PPP links. The Basic Rate Interface has 2 time slots of 64kbps. See *Chapter 10, Integrated Services Digital Network (ISDN)* for detailed information about configuring ISDN Basic Rate interfaces.

A powerful feature of the switch's support for TDM is the ability to use an interface for ISDN and static PPP links simultaneously. The slots available on the interface are statically apportioned, by command, between static TDM and dynamic ISDN use. For example on an E1 Primary Rate interface slots 1 to 20 could be reserved for ISDN calls and slots 21 to 31 for static TDM links. Note that not every telecommunication service provider is able to support simultaneous static and dynamic use of Basic Rate and Primary Rate ISDN services.

## E1/T1 Time Division Multiplexing

An E1 or T1 TDM link is best thought of as a number of leased lines, each of which may have a different bandwidth (in 64 kbps increments) and a different destination, but all sharing a single physical connection to the network.

Figure 30-1 on page 30-3 illustrates how individual E1/T1 links into a digital network may be used to provide multiple wide area connections. Switch A uses three slots to connect to Switch B, eight slots to connect to Switch C, and one slot to connect to Switch D. There is also a connection between Switch C and Switch D using two slots.

The digital network may consist of a public Digital Data Network (DDN — the core of modern telephone networks), or it may be a private network built from equipment such as microwave links, E1/T1 switches and multiplexers. Within the digital network the individual time slots from each link are dropped from one data stream and inserted into another data stream to switch the time slots to their destination.



*Non-ISDN E1/T1 links are semipermanently configured by the network provider. The bandwidths and destinations can be changed to suit network requirements, however, this is done on a static basis, not dynamically.*

Figure 30-1: Illustration of an E1/T1 network.

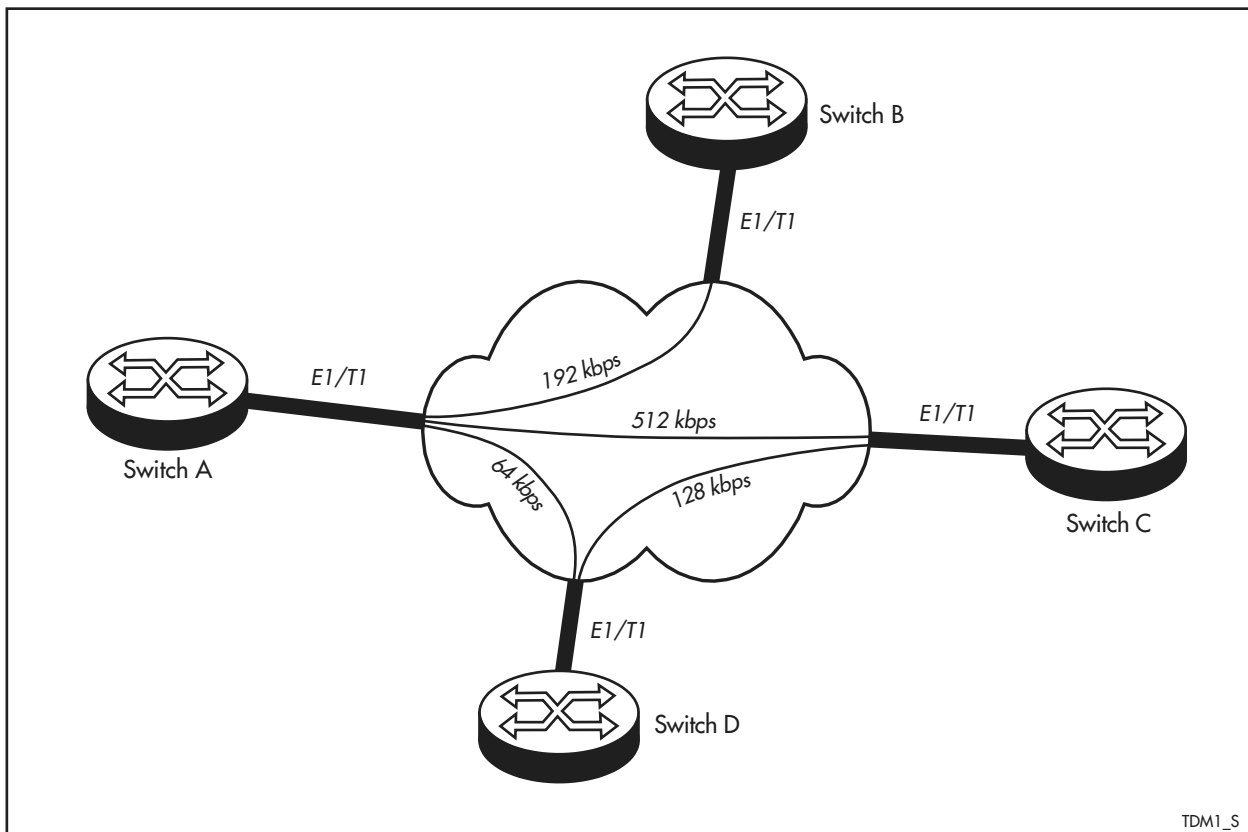

## Static E1/T1 TDM Versus ISDN Calling

In an E1/T1 TDM network a single HDLC communications controller channel is used by the network equipment for each link, irrespective of how many time slots are used by that link. By allowing links of any number of time slots up to a maximum of 31 (E1) or 24 (T1) to be configured, aggregate links of  $N \times 64$  kbps bandwidth are created.

Static E1/T1 TDM aggregation is different from other methods of combining time slots, such as creating bundles of ISDN call connections with PPP multilink. For aggregate links created using multiple ISDN calls and multilink, data on each of the calls may take a different path through the network and so arrive at the destination at a different time. Each ISDN call effectively operates as a separate HDLC link and extra overhead is required to reassemble the packets at the destination. Static E1/T1 does not have this differential delay problem, since when the link is commissioned, it is configured so that data on all time slots travels the same path. In effect, data for a single HDLC channel is *distributed* across all the time slots.

Static E1/T1 TDM also has the advantage that one end of a link can use E1/T1 while the other end of the link can use a simpler synchronous connection. This feature can be used to build a star network with a E1/T1 link to the central site and multiple lower speed links to remote sites (Figure 30-2 on page 30-4). Within the DDN the individual channels are switched to the required destination, but rather than using E1/T1 to the remote switch, a lower speed line and digital line driver are used to connect the switch via a synchronous interface.

Figure 30-2: A TDM star network.

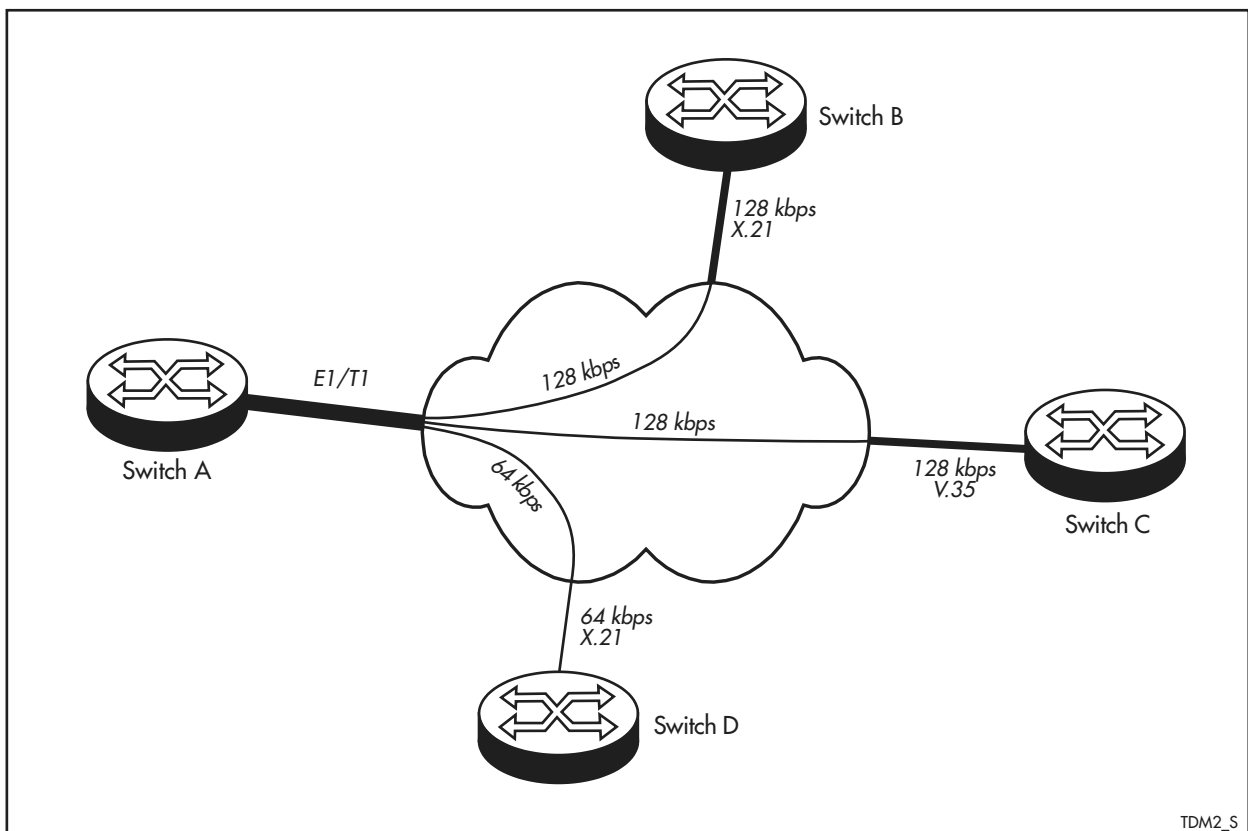

Subject to availability of the service from the telecommunications service provider, the switch is able to provide the flexibility of ISDN calls and the efficiency of static E1/T1 TDM links on a single Primary Rate interface. This offers a powerful mechanism for sharing the cost of an E1/T1 link while satisfying requirements for dynamic and static links. As the balance of those requirements change the switch can be reconfigured to apportion more or less slots to static and dynamic applications.

## BRI Time Division Multiplexing

A Basic Rate interface provides 2 x 64kbps links (called B1 and B2) and one 16kbps link (called the D channel). The D channel is used for call control in ISDN applications. Some service providers use the Basic Rate technology to provide static links in which case the D channel is not used at all. Other services (German Monopol for example) provide standard ISDN on one 64kbps link and the D channel as well as one static 64kbps link.

## Configuration Examples

---

The following examples illustrate some of the options for configuring TDM on the switch.

### Configuring static E1/T1 TDM on a PRI

The following example illustrates the steps required to configure the switch to provide static E1/T1 TDM. The TDM facility provides a mechanism for mapping one or more time slots, collectively referred to as a *TDM group*, to a single PPP interface. A TDM group is equivalent to a single physical synchronous interface or a single ISDN B channel. A TDM group may be associated with only one PPP interface at any one time, but a PPP interface can be configured to use one or more TDM groups, just as a PPP interface can be configured to use one or more synchronous interfaces and/or ISDN B channels.

Configuring a PPP interface to use one or more E1/T1 time slots consists of three steps:

- Configure a PRI port for static E1/T1 TDM
- Create a TDM group.
- Create a PPP interface over the TDM group.

Once a PPP interface has been configured, higher layer modules can use it to transport data.

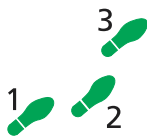

#### To configure a PRI port for static E1/T1 TDM:

##### 1. Configure the physical parameters of the PRI port.

The correct earthing configuration must be set for the PRI interface using the appropriate jumpers on the PRI interface card. See the *Rapier Switch Hardware Reference* for details.

The configuration of the PRI interface may need to be changed from the defaults. See *Configuring and Controlling the Primary Rate Interface on*

page 10-20 of Chapter 10, *Integrated Services Digital Network (ISDN)* for more information about configuring PRI interfaces.

## 2. Set the mode of the PRI interface.

The mode of the PRI port must be changed from ISDN to TDM, using the command:

```
SET PRI=0 MODE=TDM
```



*The MODE parameter affects the way the switch behaves when connected to a network to the extent that if configured inappropriately for the network to which it is connected it may not conform to the national standards applying to that network. Therefore care must be taken when using this command. Please seek the advice of your authorised distributor or reseller or telecommunications service provider when changing the mode of operation from the default, which is the correct mode for connecting to a standard ISDN network.*

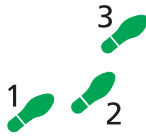

## To define a TDM group:

### 1. Create a group and assign it a name.

A TDM group comprises one or more slots (numbered 1 to 31), and is identified by a user-defined name up to 15 characters in length. The group name must be unique as it is used globally and not for just a single interface. Multiple slot groups can be created on a single PRI port, but each slot may only be used by one group at a time. In this example a TDM group named “foo” is created to use slot 2, using the command:

```
CREATE TDM GROUP=FOO INTERFACE=PRI0 SLOTS=2
```

### 2. Add or remove extra slots.

Slots may be added to or removed from a slot group. Add slot 3 to the TDM group “foo”, using the command:

```
ADD TDM GROUP=FOO SLOTS=3
```

Note that the network configuration will have to be altered by the network provider before any additional slots can be used to transport data.

### 3. Check the configuration.

To display the defined slot groups, use the command:

```
SHOW TDM GROUP
```

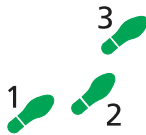

## To create a PPP interface over the TDM group:

### 1. Create the PPP interface and specify the TDM group as the physical interface.

A PPP interface must be created to use the TDM group, using the command:

```
CREATE PPP=0 OVER=TDM-foo
```

### 2. Add additional TDM groups to the PPP interface.

If more than one TDM group has been defined, the PPP interface can be configured to use additional TDM groups, using the command:

```
CREATE TDM=BAR INTERFACE=PRI0 SLOTS=7-9
ADD PPP=0 OVER=TDM-BAR
```

## Configuring TDM on a BRI

The following example illustrates how to configure a Basic Rate interface for ISDN on the B1 and D channels, and TDM on the B2 channel. Once the interface has been configured ISDN calls may be made over the interface in the same way as over a Basic Rate interface that is dedicated to ISDN operation. See *Chapter 10, Integrated Services Digital Network (ISDN)* for more information about ISDN calls. A TDM group is set up to use the B2 channel and a PPP interface is created to use the TDM group as its physical interface. The two steps of this process that are described here are:

- Configure a BRI port for ISDN and BRI TDM
- Create a TDM group

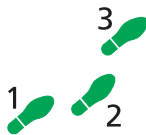

### To configure a BRI port for ISDN and TDM:

#### 1. Configure the physical parameters of the BRI port.

When a BRI link is used to provide a static link the service provider may disable normal activation and deactivation procedures since the presence of a static link implies that the interface should always be activated. This is accommodated with the command:

```
SET BRI=instance ACTIVATION=ALWAYS
```

where *instance* is the number of the BRI port.

#### 2. Set the mode of the BRI interface.

The mode of the BRI port must be changed from the default of ISDN to MIXED, using the command:

```
SET BRI=instance MODE=MIXED ISDNSLOTS=1 TDMSLOTS=2
```

where *instance* is the number of the BRI port. The ISDNSLOTS parameter identifies the slot (B1) that is available for an ISDN call and the TDMSLOTS parameter identifies slot B2 as available for a TDM group.

#### 3. Create a TDM group and assign a name.

The TDM group in this case will be called group2 and will use the B2 channel of the BRI0 interface. The group is created with the command:

```
CREATE TDM GROUP=group2 INTERFACE=bri0 SLOTS=2
```

## Command Reference

This section describes the commands available on the switch to configure and manage the TDM facility.

TDM requires the PRI or BRI module to be enabled and configured correctly. See *Chapter 10, Integrated Services Digital Network (ISDN)* for a detailed description of the commands required to enable and configure PRI and BRI interfaces.

See *Conventions on page xciii of Preface* at the front of this manual for details of the conventions used to describe command syntax. See *Appendix A, Messages* for a complete list of messages and their meanings.

## ADD TDM

---

**Syntax** `ADD TDM GROUP=groupname SLOTS=slotlist`

where:

- *groupname* is a character string, 1 to 15 characters in length. It may contain any alphanumeric character.
- *slotlist* is a character string defining a list of slots. For PRI interfaces it may include numbers 1 to 31 to indicate a time slot, commas to separate individual time slots and dashes to indicate an inclusive range. For example 1-6,17,27-30 would add slots 1,2,3,4,5,6,17,27,28,29 and 30. For BRI interfaces valid slot numbers are 1 and 2, corresponding to the B1 and B2 channels respectively.

**Description** This command adds the specified time slots to the specified TDM group.

The GROUP parameter specifies the name of the TDM group to which the time slots are to be added. The group must have been created previously with the CREATE TDM command on page 30-8.

The SLOTS parameter specifies a comma-separated list of time slots to be added to the TDM group. A range of consecutive slots can be indicated by separating the first and last slots by a hyphen. The time slots may not already be in use by another TDM group. Slots can not be added to an unstructured TDM group.

**Examples** To add slots 5, 7 and 15-20 to TDM group video, use the command:

```
ADD TDM GROUP=video SLOTS=5,7,15-20
```

**See Also** CREATE TDM  
DELETE TDM  
DESTROY TDM  
PURGE TDM  
SHOW TDM

## CREATE TDM

---

**Syntax** `CREATE TDM GROUP=groupname INTERFACE=interface  
{SLOTS=slotlist|UNSTRUCTURED}`

where:

- *groupname* is a character string, 1 to 15 characters in length. It may contain any alphanumeric character.
- *interface* is the name of a PRI or BRI physical interface (e.g. PRI0).
- *slotlist* is a character string defining a list of slots. For PRI interfaces it may include numbers 1 to 31 to indicate a time slot, commas to separate individual time slots and dashes to indicate an inclusive range. For example 1-6,17,27-30 would add slots 1,2,3,4,5,6,17,27,28,29 and 30. For BRI

interfaces valid slot numbers are 1 and 2, corresponding to the B1 and B2 channels respectively.

**Description** This command creates a new TDM group for the specified PRI or BRI interface, and associates one or more time slots of the interface with the group.

The GROUP parameter specifies the name of the TDM group to create. The name must be globally unique, that is, no other TDM group for any interface on the switch may have the same name. More than one TDM group may be associated with the same interface, provided the TDM groups have different names and different lists of time slots.

The INTERFACE parameter specifies the interface with which the group is associated. The interface must be set to TDM or MIXED mode, using the SET PRI command on page 10-105 of *Chapter 10, Integrated Services Digital Network (ISDN)* or the SET BRI command on page 10-95 of *Chapter 10, Integrated Services Digital Network (ISDN)*.

The SLOTS parameter specifies the time slots to be assigned to the TDM group. The time slots may not already be in use by another TDM group. The SLOTS and UNSTRUCTURED parameters are mutually exclusive and may not be specified together in the same command.

The UNSTRUCTURED parameter specifies that the group should use all the available bandwidth on an E1 TDM link. The E1 PRI interface must be set to TDM mode, not MIXED mode (see *Configuring and Controlling the Primary Rate Interface on page 10-20 of Chapter 10, Integrated Services Digital Network (ISDN)* and the SET PRI command on page 10-105 of *Chapter 10, Integrated Services Digital Network (ISDN)*). Unstructured mode is not supported on a T1 or BRI link. An unstructured group may be the only group on an interface as it effectively uses all the time slots. The UNSTRUCTURED and SLOTS parameters are mutually exclusive and may not be specified together in the same command.

**Examples** To create a TDM group named "video", with slots 2-7 and 11-15 of PRI port 1, use the command:

```
CREATE TDM GROUP=video INTERFACE=PRI1 SLOTS=2-7,11-15
```

To create a TDM group named "bigpipe" that uses all the bandwidth of PRI interface 0, use the command:

```
CREATE TDM GROUP=bigpipe INTERFACE=PRI0 UNSTRUCTURED
```

To create a TDM group named "video" with slot 1 of the BRI port 1, use the command:

```
CREATE TDM GROUP=video INTERFACE=BRI1 SLOTS=1
```

**See Also** ADD TDM  
DELETE TDM  
DESTROY TDM  
PURGE TDM  
SHOW TDM

## DELETE TDM

---

**Syntax** DELETE TDM GROUP=*groupname* SLOTS=*slotlist*

where:

- *groupname* is a character string, 1 to 15 characters in length. It may contain any alphanumeric character.
- *slotlist* is a character string defining a list of slots. For PRI interfaces it may include numbers 1 to 31 to indicate a time slot, commas to separate individual time slots and dashes to indicate an inclusive range. For example 1-6,17,27-30 would add slots 1,2,3,4,5,6,17,27,28,29 and 30. For BRI interfaces valid slot numbers are 1 and 2, corresponding to the B1 and B2 channels respectively.

**Description** This command deletes one or more time slots from the specified TDM group.

The GROUP parameter specifies the name of the TDM group from which the time slots are to be deleted. The group must already exist.

The SLOTS parameter specifies the time slots to be assigned to the TDM group. The time slots may not already be in use by another TDM group. The SLOTS and UNSTRUCTURED parameters are mutually exclusive and may not be specified together in the same command.

**Examples** To delete slots 11-15 from the TDM group video, use the command:

```
DESTROY TDM GROUP=video SLOTS=11-15
```

**See Also** ADD TDM  
CREATE TDM  
DESTROY TDM  
PURGE TDM  
SHOW TDM

## DESTROY TDM

---

**Syntax** DESTROY TDM GROUP=*groupname*

where:

- *groupname* is a character string, 1 to 15 characters in length. It may contain any alphanumeric character.

**Description** This command destroys the specified TDM group and releases all the time slots used by the group.

The GROUP parameter specifies the name of the TDM group to delete. The group must already exist, and no user modules may be attached to the group.

**Examples** To destroy the TDM group video, use the command:

```
DESTROY TDM GROUP=video
```

**See Also** ADD TDM  
CREATE TDM  
DELETE TDM  
PURGE TDM  
SHOW TDM

---

## PURGE TDM

---

**Syntax** PURGE TDM GROUP

**Description** This command destroys all TDM groups. If any TDM group has a user module attached to it, the command will fail.

**Examples** To remove all TDM groups, use the command:

```
PURGE TDM GROUP
```

**See Also** ADD TDM  
CREATE TDM  
DELETE TDM  
DESTROY TDM  
SHOW TDM

---

## SHOW TDM

---

**Syntax** SHOW TDM GROUP [=groupname] [INTERFACE=interface]

where:

- *groupname* is a character string, 1 to 15 characters in length. It may contain any alphanumeric character.
- *interface* is the name of a PRI or BRI physical interface (e.g. PRI0).

**Description** This command displays information about the TDM groups configured on the switch (Figure 30-3 on page 30-12, Table 30-1 on page 30-12). Only groups associated with PRI or BRI ports set to TDM or MIXED mode will be displayed. If a TDM group name is specified then only information about that group will be displayed. The specified group must exist.

If the INTERFACE parameter is specified then only TDM groups associated with the specified PRI or BRI interface will be displayed. The specified interface must exist and be set to TDM mode.

If both the group name and interface are specified, then the TDM group must be defined for the interface and the interface must be in TDM or MIXED mode.

**Figure 30-3: Example output from the SHOW TDM GROUP command.**

Interface	Group Name	User	Speed	Slots
-----				
pri0	group1	Yes	512K	1, 5, 7-12
	group2	No	256K	2-4, 6
	group3	Yes	512K	13-20
pri1	group4	Yes	320K	3, 9-13
	group5	No	320K	2-5, 6
	group6	Yes	576K	1, 7-8, 25-29, 31
-----				

**Table 30-1: Parameters displayed in the output of the SHOW TDM GROUP command.**

Parameter	Meaning
Group name	The name of the TDM group.
User	Whether or not a user module is attached to the TDM group; one of "Yes" or "No".
Speed	The aggregate speed of the group of slots.
Slots	The slots assigned to the TDM group, or "unstructured" if the group is an unstructured TDM group on an E1 PRI interface.

**Examples** To display all the TDM groups that are defined on the switch, use the command:

```
SHOW TDM GROUP
```

To display the TDM groups that are defined only for BRI interface 0, use the command:

```
SHOW TDM GROUP INTERFACE=BRI0
```

To display only the TDM group video, use the command:

```
SHOW TDM GROUP=video
```

**See Also** ADD TDM  
CREATE TDM  
DELETE TDM  
DESTROY TDM  
PURGE TDM