

PORT INTERFACE CARD

HARDWARE REFERENCE

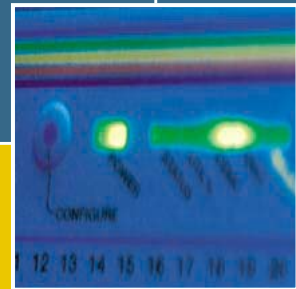
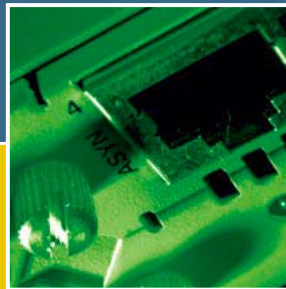
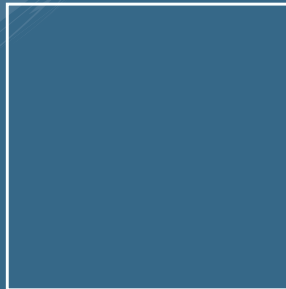

Port Interface Card Hardware Reference
Document Number C613-03023-00 REV H.

Copyright © 1999-2003 Allied Telesyn International, Corp.
19800 North Creek Parkway, Suite 200, Bothell, WA 98011, USA.

All rights reserved. No part of this publication may be reproduced without prior written permission from Allied Telesyn.

Allied Telesyn International, Corp. reserves the right to make changes in specifications and other information contained in this document without prior written notice. The information provided herein is subject to change without notice. In no event shall Allied Telesyn be liable for any incidental, special, indirect, or consequential damages whatsoever, including but not limited to lost profits, arising out of or related to this manual or the information contained herein, even if Allied Telesyn has been advised of, known, or should have known, the possibility of such damages.

All trademarks are the property of their respective owners.

Contents

Models Covered By This Reference	4
Why You Should Read This Reference	4
Where To Find More Information	4
PIC Overview	5
Hardware Features Common to All Models	5
PIC Model Descriptions	6
AT-AR020 PRI E1/T1 PIC	6
AT-AR021(S) BRI-S/T PIC	7
AT-AR021(U) BRI-U PIC	9
AT-AR022 ETH PIC	10
AT-AR023 SYN PIC	11
AT-AR024 ASYN4 PIC	12
AT-AR026 4ETH PIC	13
AT-AR027 VoIP-FXS PIC	17
PIC Interfaces	18
Asynchronous Interface	18
Synchronous Interface	19
Ethernet Interfaces	20
Primary Rate ISDN Interface	21
VoIP FXS Interface	22
Hot Swapping	22
Hot Swapping the AR040 NSM with PICs	23
How to Hot Swap a PIC	23
Behaviour of Hot Swapped Interfaces	25
PIC Testing and Verification	27
Cables and Loopback Plugs for PICs	30
Transition Cables for the AT-AR023 PIC	30
ISDN Interface Cables	37
BT Adaptor Cable for the AT-AR027 PIC	39
Terminal and Modem Cables	39
Loopback Plugs for Testing Interfaces	41
Test Facility	43
Asynchronous Interface Tests	44
WAN Port Tests	44
Troubleshooting	45
Contacting Us	45

Models Covered By This Reference

This Hardware Reference includes information on the following models:

- AT-AR020 PRI E1/T1
- AT-AR021 (S) BRI- S/T
- AT-AR021 (U) BRI-U
- AT-AR022 ETH
- AT-AR023 SYN
- AT-AR024 ASYN4
- AT-AR026 4ETH
- AT-AR027 VoIP-FXS

The latest Hardware Reference can be found at www.alliedtelesyn.co.nz/support/support.html.

Why You Should Read This Reference

This Reference has been developed to familiarise you with the hardware features of Port Interface Cards (PICs). The Reference provides information that will assist you with the process of using and maintaining PICs.

Where To Find More Information

There are several sources of further information:

- The *Port Interface Card Quick Install Guide*, which outlines the procedure for installing PICs. This Guide is bundled with each PIC, and is also on the CD-ROM bundled with recently purchased switches or routers. The guide can also be downloaded from www.alliedtelesyn.co.nz/support/support.html.
- The Hardware Reference or Software Reference for your switch or router, which provide detailed information on the operational requirements of each switch, router, or network configuration.
- www.alliedtelesyn.co.nz.

PIC Overview

PICs provide a cost effective and flexible mechanism for adding new or additional network interfaces to switches or routers. By adding or changing PICs, network interface capabilities can be upgraded without replacing the switch or router. A PIC can provide additional network interfaces, or can be replaced with a different PIC to provide alternative interface types.

The following PICs are currently available:

- AT-AR020 PRI E1/T1 PIC with primary rate ISDN
- AT-AR021 (S) BRI- S/T PIC with basic rate ISDN
- AT-AR021 (U) BRI-U PIC with basic rate ISDN
- AT-AR022 ETH PIC with a dual Ethernet 10BASE-T/AUI port
- AT-AR023 SYN PIC with a single 2Mbps synchronous port
- AT-AR024 ASYN4 PIC with four asynchronous ports
- AT-AR026 4ETH PIC with four 10BASE-T/100BASE-TX ports
- AT-AR027 VoIP-FXS with two Foreign Exchange Voice over IP ports

See the following hardware descriptions for more information on each PIC.

Hardware Features Common to All Models

This section outlines the hardware features that are common to all PIC models.

Environmental Conditions

- Operating temperature range: 0 to 40° C (32 to 104° F)
- Storage temperature range: -25 to 70° C (-13 to 158° F)
- Relative humidity range: 5 to 95% non-condensing

Regulatory Standards

- EMC: CISPR22 class A, FCC class A, and VCCI class I
- Immunity testing to EN50082 levels 2 (ESD), 3 (susceptibility), 4 (fast transients), 5 (power surge), and 6 (RF immunity)
- Safety: UL1950, CSA22.2, EN60950 and CE

PIC Model Descriptions

This section provides detailed information on the features of each PIC model.

AT-AR020 PRI E1/T1 PIC

The AT-AR020 PRI E1/T1 PIC provides a single G.703/Primary Rate ISDN WAN port with an RJ-45 connector.

The card supports both E1 and T1 operation. A jumper selects the required option and impedance. A second jumper selects NT (*Network Terminator*) or TE (*Terminal Equipment*) mode, and the current mode is displayed by the NT LED. The normal operating mode is LT. Jumper locations are shown in Figure 2 on page 7, and jumper functions are listed in Table 2 on page 7.

The AT-AR020 PRI E1/T1 PIC is shown in Figure 1 on page 6, and the functions of the LEDs are listed in Table 1 on page 6.

Figure 1: AT-AR020 PRI E1/T1 PIC.

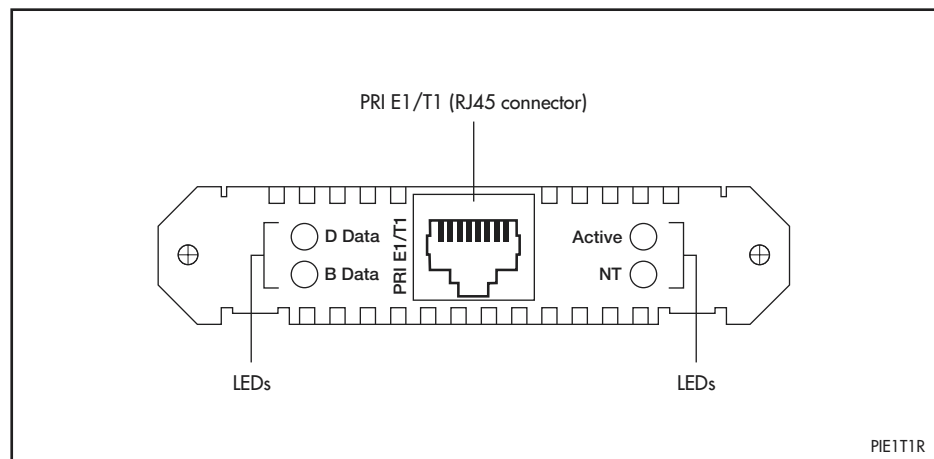
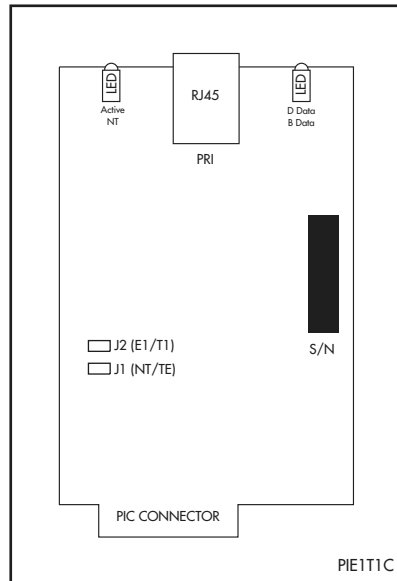

Table 1: AT-AR020 PRI E1/T1 PIC LED functions.

LED	Function
D Data	[ISDN mode only] Lit when HDLC packets are being exchanged between the switch or router and the ISDN switch over the D (signalling) channel.
B Data	Lit when HDLC packets are being exchanged between the switch or router and another end system device (normally another switch or router) over any of the B (data) channels.
Active	Lit whenever operational (i.e., no RAI or AIS) frames are being received.
NT	[ISDN mode only] Lit when the PRI1 is operating in NT mode. This LED should not be lit during normal operation.

Figure 2: Location of jumpers on the AT-AR020 PRI E1/T1 PIC board.**Table 2: Functions of jumpers on the AT-AR020 PRI E1/T1 PIC board.**

Jumper	Function	Default
J1	Selects ISDN NT mode (installed) or TE mode (not installed).	Not installed.
J2	Selects T1 mode (installed) or E1 mode (not installed).	Not installed.



Jumper J1 is factory set to ISDN TE mode for normal operation and should not be changed without contacting your ISDN service provider, or Authorised Allied Telesyn distributor or reseller.



Earlier versions of this card also have a J3 interface jumper. If present, this jumper must be installed for E1 mode and removed for T1 mode.



Remove the data cable from the RJ-45 connector before attempting to remove the PIC from the switch or router.

AT-AR021(S) BRI-S/T PIC

The AT-AR021(S) BRI-S/T PIC provides a single Basic Rate ISDN S/T WAN port. The BRI port has an RJ-45 connector.

The AT-AR021(S) PIC is shown in Figure 3 on page 8 and the functions of the LEDs are listed in Table 3 on page 8. Jumper locations are shown in Figure 4 on page 8, and jumper functions are listed in Table 3 on page 8.

Figure 3: AT-AR021(S) BRI-S/T PIC.

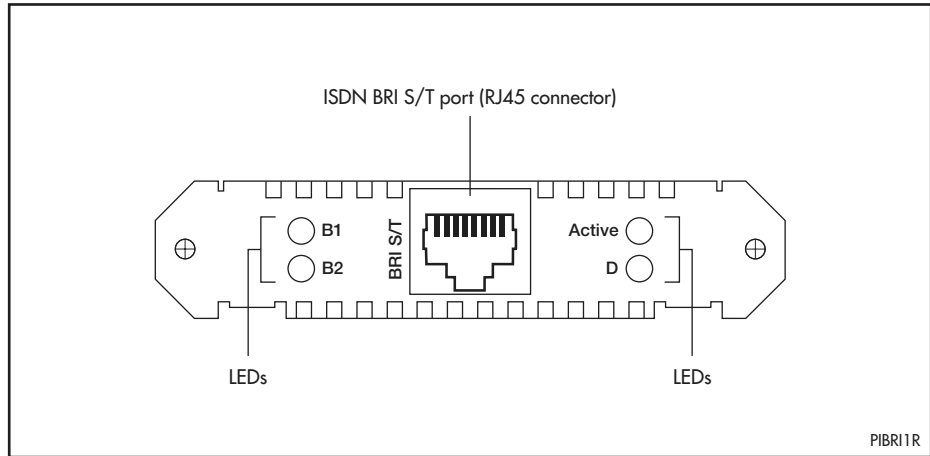

Figure 4: Location of jumpers on the AT-AR021(S) BRI-S/T PIC board.

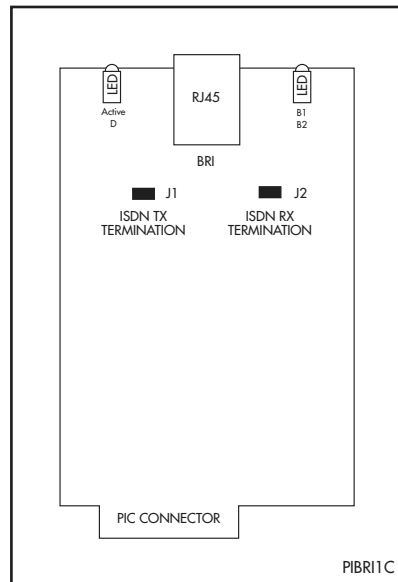

Table 3: AT-AR021(S) BRI-S/T PIC LED functions.

LED	Function
B1, B2	For on-demand ISDN, lit when there is a call up over the respective B channel and flashing when data is being exchanged. For permanent circuits, lit when HDLC packets are being exchanged between the switch or router and another TE end system device (normally another switch or router) over the respective B (data) channel.
Active	Lit when the BRI has successfully completed the exchange of INFO 1 and INFO 2 signals, and INFO 3 and INFO 4 signals are present on the link. This means that the ISDN interface is correctly connected to a working NT device.
D	Lit when HDLC packets are being exchanged between the switch or router and the ISDN switch over the D (signalling) channel.

Table 4: Functions of jumpers on the AT-AR021(S) BRI-S/T PIC board.

Jumper	Function
J1	100Ω termination for TX.
J2	100Ω termination for RX.

The termination jumpers (J1 and J2) are normally removed as the building wiring will provide the correct termination for an ISDN TE-to-NT circuit. When the BRI is connected in a point-to-point configuration, J1 and J2 may need to be installed to terminate the line pairs with internal 100Ω resistors. For detailed information, see the *Integrated Services Digital Network (ISDN)* chapter of the Software Reference or Reference Manual for your switch or router.



If you are unsure of whether to terminate the line or not, contact your ISDN service provider, or your Authorised Allied Telesyn distributor or reseller.

AT-AR021(U) BRI-U PIC

The AT-AR021(U) BRI-U PIC provides a single Basic Rate ISDN U Interface WAN port. The BRI port has an RJ-45 connector.

There are no user-configurable jumpers or dip switches on the AT-AR021(U) BRI-U PIC board.

The AT-AR021(U) PIC is shown in Figure 5 on page 9, and the functions of the LEDs are listed in Table 5 on page 10.

Figure 5: AT-AR021(U) BRI-U PIC.

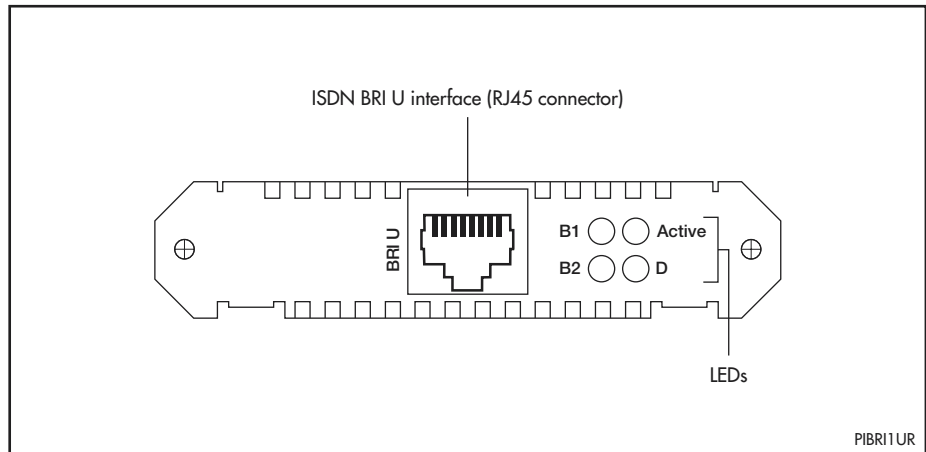

Table 5: AT-AR021(U) BRI-U PIC LED functions.

LED	Function
B1, B2	Lit when HDLC packets are being exchanged between the switch or router and another TE end system device (normally another switch or router) over the respective B (data) channel For ISDN, lit when there is a call up over the respective B channel and flashing when data is being exchanged.
Active	Lit when the U interface is in the <i>Activated</i> state (i.e., it is fully operational at layer 1).
D	Lit when HDLC packets are being exchanged between the switch or router and the ISDN switch over the D (signalling) channel.



Before removing this PIC, ensure that the power to the switch or router has been disconnected and that the ISDN connection has been removed from the BRI U interface connector. Dangerous voltages may be present on an ISDN line interface.

AT-AR022 ETH PIC

The AT-AR022 ETH PIC provides a dual Ethernet 10BASE-T/AUI port. Only one interface type can be active at any one time and the PIC automatically senses which interface is in use. The 10BASE-T interface uses an RJ-45 connector and the AUI interface uses a DB15 connector.



AT-AR022 ETH PICs are not recommended for use in AT-AR040 NSM PIC bays, as performance of these interfaces is likely to be reduced and packet loss may occur.

The AT-AR022 ETH PIC is shown in Figure 6 on page 10, and the functions of the LEDs are listed in Table 6 on page 11.

Figure 6: AT-AR022 ETH PIC.

Table 6: AT-AR022 ETH PIC LED functions.

LED	Function
Link	Lit when the Ethernet interface is connected to a device (e.g. a hub) which is generating link pulses.
Data	Lit when data is being transmitted or received over the Ethernet interface.

The AT-AR022 PIC is a single card. Figure 7 on page 11 shows the layout of the board.

Figure 7: Location of main components on the AT-AR022 ETH PIC.

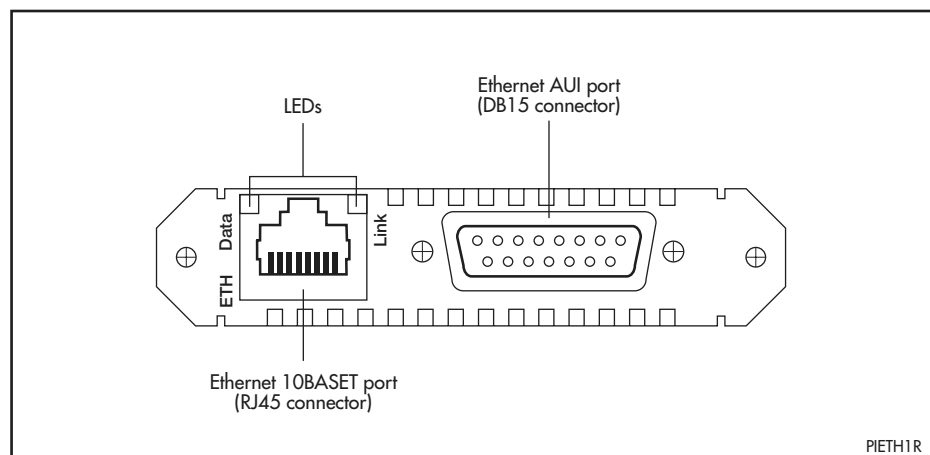
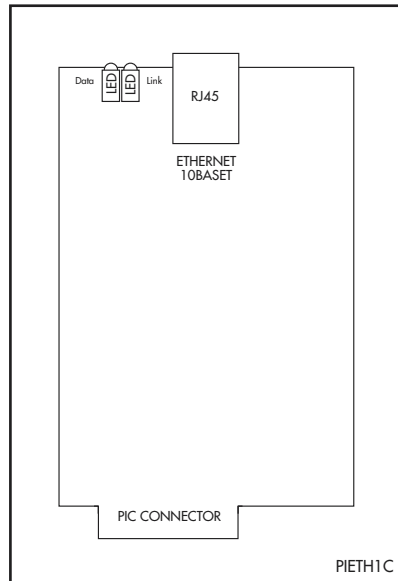
AT-AR023 SYN PIC

The AT-AR023 SYN PIC provides a single synchronous port operating at speeds up to 2Mbps. The synchronous port has a 50-way AMPLIMITE universal connector which supports RS-232/V.28, V.35 and X.21 interface standards in DTE and DCE modes.

A transition cable is required to convert the AMPLIMITE connector to the correct physical interface. The switch does not need to be rebooted to change the interface type.

There are no user-configurable jumpers or dip switches on the AT-AR023 SYN PIC board.

The AT-AR023 SYN PIC is shown in Figure 8 on page 12, and the functions of the LEDs are listed in Table 7 on page 12.

Figure 8: AT-AR023 SYN PIC.

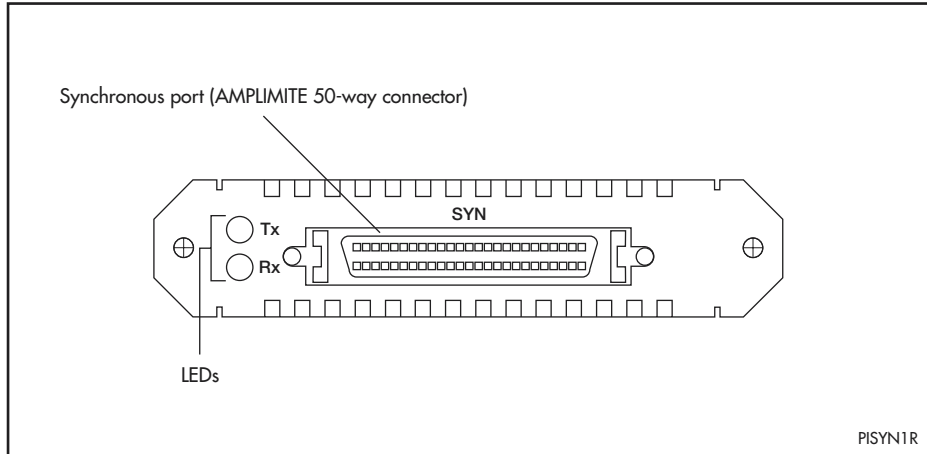

Table 7: AT-AR023 SYN PIC LED functions.

LED	Function
Tx	Lit when data is being transmitted over the synchronous interface.
Rx	Lit when data is being received on the synchronous interface.

AT-AR024 ASYN4 PIC

The AT-AR024 ASYN4 PIC provides four additional asynchronous RS-232 ports with RJ-45 connectors for use up to 115 Kbps.

There are no user-configurable jumpers or dip switches on the AT-AR024 ASYN4 PIC board.

The AT-AR024 ASYN4 PIC is shown in Figure 9 on page 12. The ASYN4 PIC does not have LEDs.

Figure 9: AT-AR024 ASYN4 PIC.

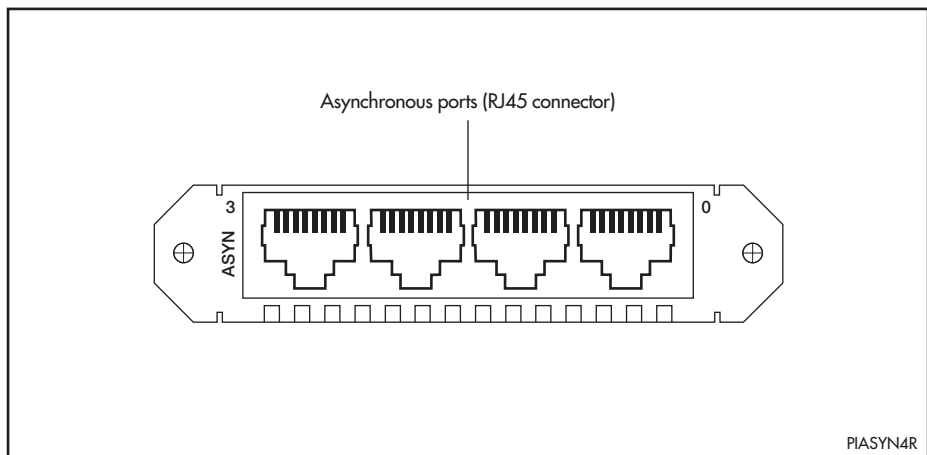

AT-AR026 4ETH PIC

The AT-AR026 4ETH PIC provides four 10BASE-T/100 BASE-TX auto-negotiating ports. The ports support wire speed unmanaged layer 2 switching and have RJ-45 connectors.

The AT-AR026 4ETH PIC is shown in Figure 10 on page 13, and the functions of the LEDs are listed in Table 8 on page 14.



AT-AR026 4ETH PICs are not recommended for use in AT-AR040 NSM PIC bays, as performance of these interfaces is likely to be reduced and packet loss may occur.

Figure 10: AT-AR026 4ETH PIC.

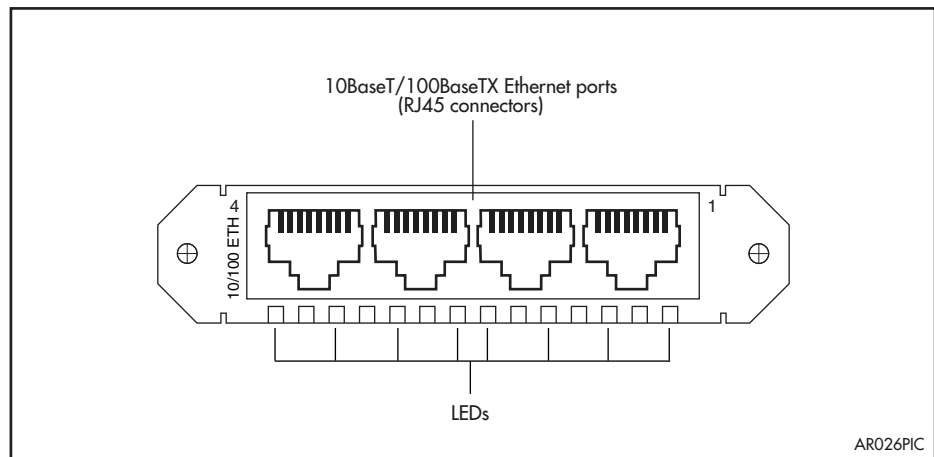

AT-AR026 features include:

- Five integrated switch ports with physical layer transceivers (four 10/100 Ethernet switch ports, and one fixed 10 Mbps port acting as the PIC to base unit connector)
- 128 kbytes of frame buffering SRAM
- 1.4 Gbps high performance memory bandwidth
- 10BASE-T and 100BASE-TX modes of operation
- LED indicators for link, activity, full/half duplex, and port speed
- Hardware based 10/100, full/half duplex, flow control, and auto-negotiation
- Individual port forced modes (full duplex, 100BASE-TX) when auto-negotiation is disabled
- Wire speed reception and transmission
- Integrated address look-up engine, supporting 1K absolute MAC addresses
- Automatic address learning, address aging, and address migration
- Broadcast storm protection
- Full duplex IEEE 802.3x flow control
- Half duplex back pressure flow control
- MDI/MDI-X auto cross over support

Some features (such as auto-negotiation, buffer size, and MAC address aging) are configured by adding or removing links on the PIC's PCB. Table 9 on page 16 lists the configurable features, their respective links, and their default settings.

Table 8: AT-AR026 4ETH PIC LED functions (Two LEDs per port).

LED	Function
Left	Lit when the port is operating at 100Mbps and full duplex.
Right	Lit when a link has been established. Flashing when data is being transmitted through the port.

The AT-AR026 PIC is a single card. Figure 11 on page 15 shows the layout of its board and configurable links.



AT-AR026 PICs do not support the Allied Ware Diagnostic or Test Facility modules.



AT-AR026 PICs include a switch chip that switches independently of the switch, router, or NSM that the PIC is installed in. The SHOW INTERFACE command will show each correctly installed AT-AR026 as a single interface (the PIC connector). The 10/100 'front side' Ethernet ports will not be shown.

Figure 11: Location of user configurable links on the AR026 4ETH PIC.

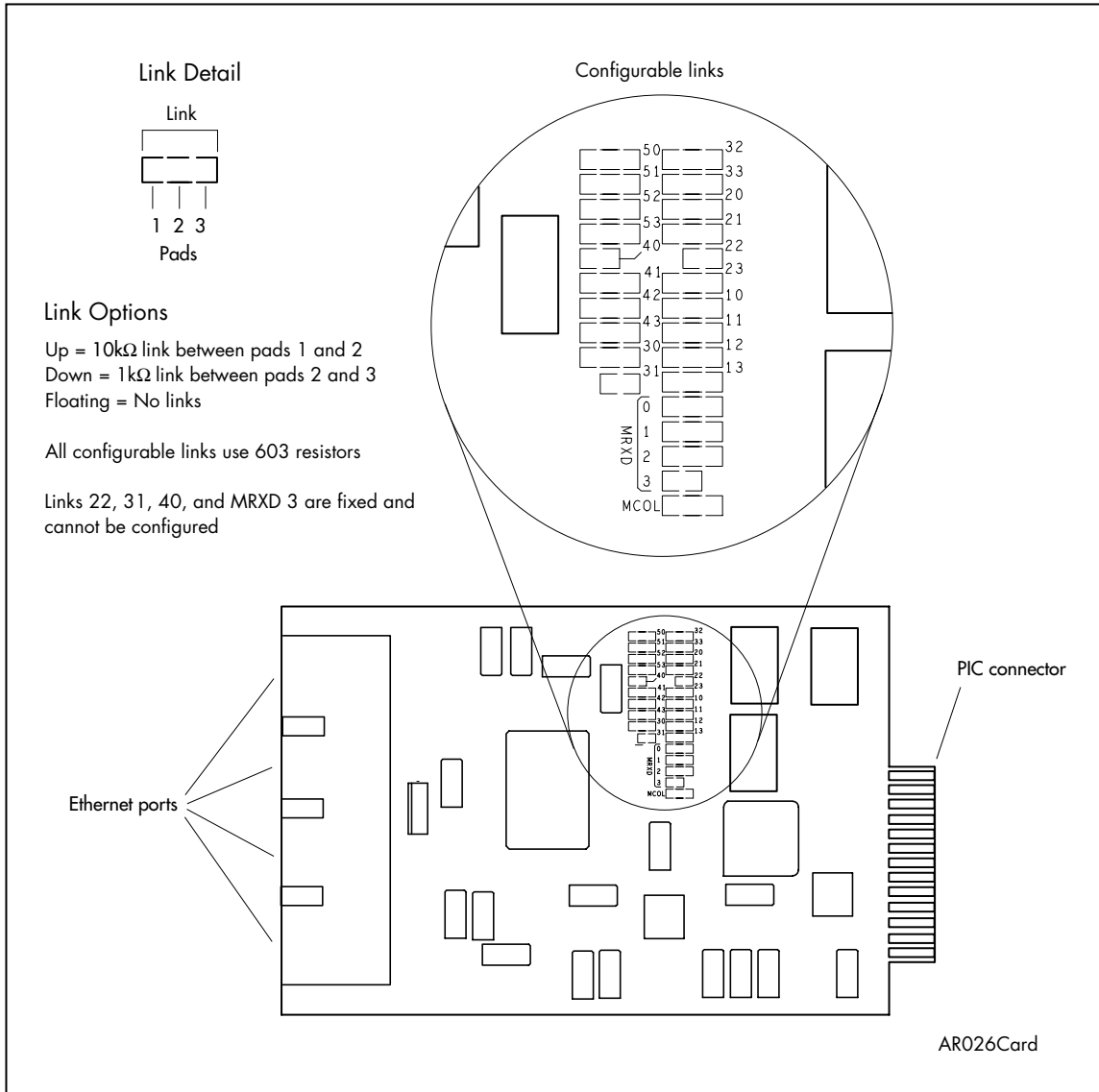

Table 9: Configurable links on the AT-AR026 4ETH PIC .

Function	Link	Up ¹	Down ²	Floating ³	Default
Set flow control on all Ethernet ports	13	Flow control	No flow control	NA	Up
Force 10BASE-T ⁴ , 100BASE-TX ⁴ , or auto-negotiation on port 1	41	100BASE-TX	10BASE-T	Auto-negotiation	Floating
Force 10BASE-T ⁵ , 100BASE-TX ⁵ , or auto-negotiation on port 2	42	100BASE-TX	10BASE-T	Auto-negotiation	Floating
Force 10BASE-T ⁶ , 100BASE-TX ⁶ , or auto-negotiation on port 3	43	100BASE-TX	10BASE-T	Auto-negotiation	Floating
Force 10BASE-T ⁷ , 100BASE-TX ⁷ , or auto-negotiation on port 4	30	100BASE-TX	10BASE-T	Auto-negotiation	Floating
Force full duplex ⁴ , half duplex ⁴ , or auto-negotiation on port 1	50	Full duplex	Half duplex	Auto-negotiation	Floating
Force full duplex ⁵ , half duplex ⁵ , or auto-negotiation on port 2	51	Full duplex	Half duplex	Auto-negotiation	Floating
Force full ⁶ , half duplex ⁶ , or auto-negotiation on port 3	52	Full duplex	Half duplex	Auto-negotiation	Floating
Force full duplex ⁷ , half duplex ⁷ , or auto-negotiation on port 4	53	Full duplex	Half duplex	Auto-negotiation	Floating
Set aggressive back-off mode in half duplex	20	Aggressive back-off	Standard back-off	NA	Up
Set back pressure in half duplex	21	Back pressure enabled	No back pressure	NA	Up
Set aging in MAC address look-up table	23	Addresses age out after 5 minutes	No address age out	NA	Up
Set a maximum limit for broadcast frames	32	Broadcast frames are limited to a maximum of 25% of frames	No limit on broadcast frames	NA	Up
Drop packets if excessive collisions occur	33	Packet transmission will continue regardless of collisions	Packets will be dropped after 16 collisions	NA	Down
Enable or disable auto-negotiation on port 1	MCOL	Disable auto-negotiation	Enable auto-negotiation	NA	Down
Enable or disable auto-negotiation on port 2	MRXD 0	Disable auto-negotiation	Enable auto-negotiation	NA	Down
Enable or disable auto-negotiation on port 3	MRXD 1	Disable auto-negotiation	Enable auto-negotiation	NA	Down
Enable or disable auto-negotiation on port 4	MRXD 2	Disable auto-negotiation	Enable auto-negotiation	NA	Down
Set 205 buffers (maximum) per port	10 & 11	NA	1k (link 10), 1k (link 11)	NA	NA
Set 512 buffers (maximum) per port	10 & 11	10k (link 11)	1k (link 10)	NA	NA
Set 768 buffers (maximum) per port	10 & 11	10k (link 10)	1k (link 11)	NA	NA
Set 512 buffers (adaptive) per port	10 & 11	10k (link 10), 10k (link 11)	NA	NA	Up (link 10) Up (link 11)

Notes for Table 9 on page 16.

1. Up = 10k Ω link between pads 1 and 2.
2. Down = 1k Ω link between pads 2 and 3
3. Floating = no link
4. Requires auto-negotiation on port 1 to be disabled (using link MCOL).
5. Requires auto-negotiation on port 2 to be disabled (using link MRXD 0).
6. Requires auto-negotiation on port 3 to be disabled (using link MRXD 1).
7. Requires auto-negotiation on port 4 to be disabled (using link MRXD 2).



Links 22, 31, 40, and MRXD 3 are fixed and should not be changed. Attempting to change these links will cause the PIC to cease functioning.

AT-AR027 VoIP-FXS PIC

The AT-AR027 VoIP-FXS PIC provides two Foreign Exchange Subscriber (FXS) ports. The ports use RJ-11 connectors and can be connected to standard analog telephony equipment such as telephones, fax machines and modems. The FXS interface supplies ring, voltage and dial tone.

The AT-AR027 VoIP-FXS PIC is shown in Figure 12 on page 17, and functions of the LEDs are listed in Table I-1 on page 18.

Figure 12: AT-AR027 VoIP-FXS PIC.

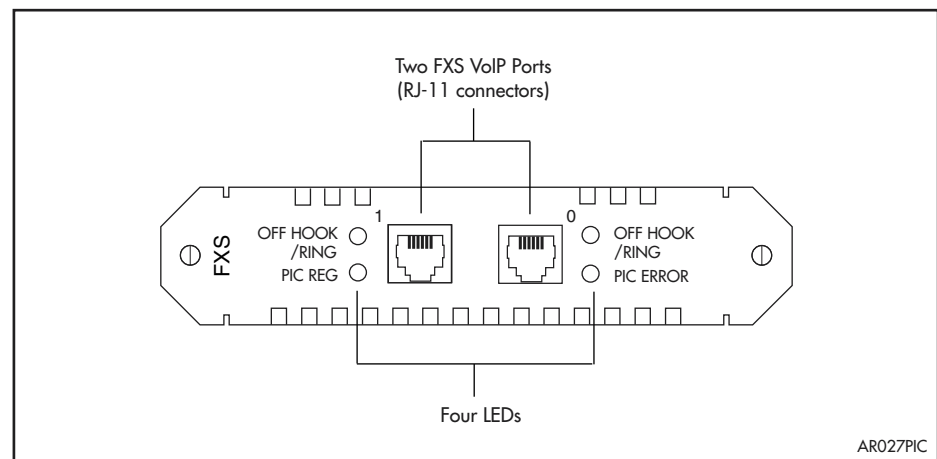

AT-AR027 features include:

- Settable ring wave form
- Settable tone generation
- Settable port gain/attenuation for transmit and receive on each port
- 600r, 600c, 900c, Cplx and Cplx2 port impedance.
- Frame buffer management
- Voice activation and silence detection
- Compatible with H.233, Session Initiation Protocol (SIP) and Media Gateway Control Protocol (MGCP)



When using AT-AR027 PICs with an AR740 router and NSM, a maximum of four AT-AR027 PICs can be installed in the router and NSM.

More information on protocols and how to configure them on the PIC can be found in the Software Reference for your switch or router.

Table I-1: AT-AR027 VoIP-FXS PIC LED functions.

LED	State	Function
Off Hook/Ring	Off	The port is on-hook
	Green	The port is off-hook
	Flashing	An incoming call is present on the port
PIC Reg	Off	The PIC is not registered with a gatekeeper and external phone calls cannot be made
	Flashing	The PIC is registered with a gatekeeper or gatekeeper has been set to "None". External calls can only be made if the PIC is registered with a gatekeeper
PIC Error	Off	The PIC is okay
	Green	An internal error has occurred. Reset the PIC using the RESET VOIP command

PIC Interfaces

This section provides detailed information on the physical and operational characteristics of PIC interfaces.

Asynchronous Interface

The AT-AR024 ASYN4 PIC provides an asynchronous interface with four ports. The interface follows the RS-232 standard and uses RJ-45 connectors. Table 10 on page 18 lists the port pin assignments.

Table 10: Pinout of the RJ-45 connectors on the AT-AR024 ASYN4 PIC (pins are numbered from left to right).

Pin	Function	Signal Direction
1	RING	Input to PIC
2	DCD	Input to PIC
3	DTR	Output from PIC
4	GND	
5	RXD	Input to PIC
6	TXD	Output from PIC
7	CTS	Input to PIC
8	RTS	Output from PIC

A range of speeds is selectable using the SET PORT command if using a router, or the SET ASYN command if using a switch. More information on these commands can be found in the *Interfaces* chapter of the Software Reference or Reference Manual for your switch or router.

Not all signals need to be connected. In particular, both DCD and CTS are not required unless the interface has been specifically set up to use them. The *Terminal Server* and *Printer Server* chapters of the Software Reference or Reference Manual for your switch or router have more details. A typical terminal connection will only require RXD, TXD and GND, but refer to the equipment manual for the connected device for more specific data.



If LPD-based printer ports are required, then the switch or router may expect to 'see' the DTR signal from the printer connected to the DCD pin of the switch. This is used to detect both the fact that the printer is 'online' and that it is 'powered-on'. This prevents print jobs being sent to a disconnected printer and lost. The Printer Server chapter of the Software Reference or Reference Manual for your switch or router has more information.

Synchronous Interface

The AT-AR023 SYN PIC provides a synchronous interface with a single AMPLIMITE 50-way port. The AMPLIMITE port is wired as a universal connector for RS-232/V.28, V.35 and X.21 interface standards in both DTE and DCE modes. A transition cable is required to convert the AMPLIMITE to the correct physical interface for the standard required (e.g., DB15 for X.21). The transition cable can be ordered from your supplier, or you can construct your own cable.

The transition cable does more than simply change the physical connector. The switch or router hardware reads the cable type from the AMPLIMITE plug and enables or disables the internal driver electronics as required. To function correctly, the cables must be identical to the cables described in "Cables and Loopback Plugs for PICs" on page 30.



The DCE cable type reverses the direction of the data lines as well as the clock lines. This cable is intended to be used when the switch or router supplies the clock for the attached device. This is commonly used when the switch or router is connected to the synchronous interface of another device or a host, without using an intermediate modem or NTU (Network Terminating Unit). Therefore, the DCE cable must only be connected to a switch or router interface that is set to generate the clock. The Interfaces chapter of the Software Reference or Reference Manual for your switch or router has more information.

The transition cable can be changed at any time. It is not necessary to power-down the switch.

When an RS-232 DCE transition cable is connected to a synchronous interface configured to generate clocks, the maximum clock speed is 38400 bps. When an X.21 DCE or V.35 DCE transition cable is connected to a synchronous interface configured to generate clocks, the maximum clock speed is 2 Mbps.

Ethernet Interfaces

Dual 10BASE-T/AUI Interfaces

The AT-AR022 ETH PIC has a dual 10BASE-T/AUI Ethernet interface. Only one Ethernet interface type can be active at any one time. The PIC auto-senses which Ethernet interface type is in use.

For performance reasons, the AT-AR022 PIC is not recommended for use in the AT-AR040 NSM. When the AT-AR040 NSM is installed in a switch or switching router, Ethernet connections should be made through the Ethernet ports. When the AT-AR040 NSM is installed in a router, AT-AR022 PICs should be installed in base-unit (router) PIC bays.

10Base-T/100Base-TX Interfaces

The AT-AR026 4ETH PIC has four 10BASE-T/100BASE-TX ports with RJ-45 connectors. Port characteristics such as speed, flow control, half/full duplex, and auto-negotiation can be set by configuring links on the PIC's PCB. See "AT-AR026 4ETH PIC" on page 13 for more information.

Basic Rate ISDN Interfaces

The AT-AR021(S) BRI-S/T and AT-AR021(U) PICs provide Basic Rate ISDN (BRI) interfaces. In both cases the connector type is RJ-45. The interfaces support two 64K B channels and one D channel.

For the AT-AR021(S) BRI-S/T PIC, the operational mode of the BRI ISDN interface (TE or NT) is determined by jumpers mounted on its board. See the AT-021(S) description on page 7 for locations and names of the jumpers. The AT-AR021(U) PIC only supports TE mode. The *Integrated Services Digital Network (ISDN)* chapter of the Software Reference or Reference Manual for your switch or router has detailed descriptions of the two operational modes. The switch or router should be configured as a TE for normal operation.

For the AT-AR021(S) BRI-S/T PIC, the termination provided by the interface may also be determined by jumpers mounted on its board. The jumpers are normally removed as the building wiring will provide the correct termination for an ISDN TE-to-NT circuit.

When the BRI is connected in a point-to-point configuration, the jumpers may need to be installed to terminate the line pairs with internal 100Ω resistors. See the AT-021(S) description on page 7 for locations and names of the jumpers. The *Integrated Services Digital Network (ISDN)* chapter of the Software Reference or Reference Manual for your switch or router has additional information. The pinout of the BRI interface is shown in Table 11 on page 21.



If you are unsure of whether to terminate the line or not, contact your ISDN service provider or your Authorised Allied Telesyn distributor or reseller.

Table 11: Pinout of the Basic Rate ISDN interface.

Pin	S/T Interface Functions	U Interface Functions
1	-	-
2	-	-
3	TX+	-
4	RX+	positive (+)
5	RX-	negative (-)
6	TX-	-
7	-	-
8	-	-

Primary Rate ISDN Interface

The AT-AR020 PRI E1/T1 PIC provides a Primary Rate ISDN interface with a single RJ-45 connector. The interface supports connection to either 100Ω T1 or 120Ω E1 networks.

Table 2 on page 7 lists the network jumper settings for the different network types.

Table 12: Connection standard for Primary Rate ISDN RJ-45 connectors (from left to right, with latch down, as viewed from the rear).

Pin	Signal
1	RX+
2	RX-
3	RX ground selection from jumper
4	TX+
5	TX-
6	TX ground selection from jumper
7	<i>Not connected</i>
8	<i>Not connected</i>

VoIP FXS Interface

The AT-AR027 VoIP-FXS PIC uses standard RJ-11 telephone sockets that provide a Tip and Ring A/B pair (Table 13 on page 22). An RJ-11 to BT adaptor cable can be used to connect telephones with BT-style plugs to the RJ-11 ports (Figure 24 on page 39).

Table 13: Pinout of the voice port RJ-11 connectors.

Pin	Function
1	Not connected
2	Not connected
3	RING
4	TIP
5	SHUNT
6	Not connected



When using AT-AR027 PICs with an AR740 router and NSM, a maximum of four AT-AR027 PICs can be installed in the router and NSM.

Hot Swapping

Hot Swapping is the installation or removal of a component (such as a PIC) without powering down or restarting the switch or router.

The following PICs can be hot swapped only if they are to be installed or removed from an AR040 NSM, and the AR040 is installed in a switch or router running Software Release 2.3.1 or later.

- AT-AR021 (S) BRI- S/T
- AT-AR021 (U) BRI-U
- AT-AR023 SYN

The following PICs cannot be hot swapped at this time.

- AT-AR020 PRI E1/T1
- AT-AR024 ASYN4
- AT-AR027 VoIP-FXS

These PICs, PICs installed directly into routers (i.e., PICs not installed in an AR040 NSM), or PICs installed in any device running Software Release 2.2.3 or earlier must be installed or removed using the Standard Method (as outlined below).

To find out which software release your switch or router is running, use the command:

```
SHOW RELEASE
```

Hot Swapping the AR040 NSM with PICs

The AT-AR040 NSM can be hot swapped with PICs installed in its PIC bays. There is no need to remove the PICs before hot swapping the NSM.

When an AR040 NSM with PIC cards is hot swapped out, and an identical combination of AR040 and PICs is hot swapped into the same bay, the software configurations for the PIC interfaces are preserved across the hot swap. In this case, modules configured to the PIC interfaces transfer to the newly swapped in interfaces.

When an AR040 NSM with PICs is hot swapped out and a different combination of AR040 and PICs is hot swapped into the same bay, new interface instances are created for any new PIC types or PIC types that are in different bays (the old interface instances are discarded). For any PIC in the combination that is replaced by a PIC of the same type, interface instances are preserved.



The recessed Hot Swap button must be used when hot swapping NSMs. See the NSM Quick Install Guide or NSM Hardware Reference for the correct procedure for hot swapping PICs.

How to Hot Swap a PIC

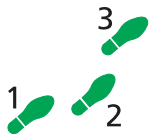

Hot Swap Installation Method:

Only use this method if the PIC is to be installed or removed from an AR040 NSM, and the NSM is installed in a switch or router running Software Release 2.3.1 or later.



WARNING: *Failure to follow this procedure when hot swapping a PIC will cause the router to crash, and may damage files stored in FLASH.*

1. Gather the tools and equipment you will need

A medium-sized flat-bladed screwdriver may be useful when loosening the PIC thumbscrews.

You should also have any cables required for connecting the PIC to a wide area network or other network devices.

2. Prepare the PIC bay for hot swap



Do not attempt to hot swap while the contents of FLASH are being modified; for instance, during FLASH compaction or when files are being loaded onto the switch or router. If the switch or router crashes while FLASH is being modified, configuration files, software release files, feature licences and other files may be damaged.

If the In Use LED (next to the NSM bay) is lit, use a pencil tip or similar object to press the recessed Hot Swap button. The In Use LED should go out and the Swap LED should light.

If the In Use LED remains lit, or if neither the In Use or Swap LED are lit, the software release does not support hot swapping, and the Standard Installation Method must be used to install or remove the PIC.

3. Remove the PIC-bay face-plate, NSM PIC-bay face-plate, or existing PIC

Loosen the thumbscrews to remove the face-plate or PIC.



Keep the face-plate for future use. If you remove the PIC, replace the face-plate to prevent dust and debris from entering the switch or router and to maintain proper airflow.

4. Unpack the PIC

In an antistatic environment, remove the PIC from its packing material. Be sure to observe ESD precautions.



Do not attempt to install a PIC or any other expansion option without observing correct antistatic procedures. Failure to do so may damage the switch or router, PIC, or expansion option. If you are unsure what the 'correct' procedures are, contact your authorised Allied Telesyn distributor or reseller.

5. If the PIC has jumpers, check that they are correctly set

AT-AR020 PRI E1/T1 and AT-AR021(S) BRI-S/T PICs have user-configurable jumpers. Check that all jumpers and other hardware configurations are set correctly on the new PIC (Table 14 on page 24 and Table 15 on page 24).

AT-AR026 4ETH PICs have user configurable links that set features such as auto-negotiation, buffer size, and MAC address aging. Descriptions of the links can be found in the *PIC Hardware Reference*.

Table 14: Functions of jumpers on the AT-AR020 PRI E1/T1 PIC board.

Jumper	Function	Default
J1	Selects ISDN NT mode (installed, test only) or TE mode (not installed).	Not installed.
J2	Selects T1 mode (installed) or E1 mode (not installed).	Not installed.



Earlier versions of the AT-AT020 PIC also have a J3 interface jumper. If present, this jumper must be installed for E1 mode and removed for T1 mode.

Table 15: Functions of jumpers on the AT-AR021(S) BRI-S/T PIC board.

Jumper	Function
J1	100Ω termination for TX.
J2	100Ω termination for RX.



Do not attempt to change any jumpers, DIP switches or other hardware configurations while the switch or router is connected to a power supply, redundant power supply, or a 'live' network. Dangerous voltages may be present on some parts of the board, even if the switch or router is not turned on.

6. Slide the PIC into place

PIC bays should be filled in numerical order, starting with the lowest available bay (e.g., bay 0) followed by bays with progressively higher numbers.

7. Secure the PIC by tightening its thumbscrews

8. Return the NSM bay to use

Press the recessed Hot Swap button. The Swap LED will go out and the In Use LED will light.

If the In Use LED lights only briefly and the Swap LED then lights continuously, the software release does not support hot swapping of this type of PIC.

9. Test the PIC

There are several ways to check that the PIC is installed and functioning correctly.

The SHOW SYSTEM command displays general system information about PICs and any other hardware installed, as well as memory, software release and patches loaded on the switch or router.

“PIC Testing and Verification” on page 27 describes the recommended procedure for testing PICs, and the Troubleshooting section on page 45 outlines possible faults and their solutions.

Behaviour of Hot Swapped Interfaces

When an interface (PIC or NSM) is hot-swapped out, its interface instances become dormant. They stay dormant until either another interface of the same type is hot-swapped into the bay, in which case they are reactivated, or an interface of a different type is hot-swapped into the bay, in which case they are discarded.

Dormant interfaces are included in the SHOW INTERFACE command output and in the SNMP interfaces MIB, marked as swapped out. In other router or switch commands, however, the router or switch behaves as though dormant interfaces do not exist.

Instances of higher-level modules (such as LAPD and Q931, ISDNCC, PPP, and IP) do not become dormant when an interface becomes dormant. Instead they behave as if the interface has stopped communicating, for example, as if the cable has been unplugged.



The configuration script is not scanned for commands relating to hot-inserted interfaces until the switch or router is restarted. These interfaces must be configured manually.



The switch or router does not update the MAC address of any hot-swapped Ethernet interface until the switch or router is restarted.

The SHOW INTERFACE command is modified to show “Swapped out” in the ifOperStatus column for dormant interface instances.

All other commands that show or set interface properties behave as if swapped-out interfaces do not exist. Commands that operate on multiple

interfaces skip swapped-out interfaces. Commands specified explicitly to a dormant interface display an error message.

Figure 13: Example output from the SHOW INTERFACE command.

```

Interfaces                                     sysUpTime:           00:00:46

DynamicLinkTraps.....Disabled
TrapLimit.....20

Number of unencrypted PPP/FR links.....0

ifIndex Interface      ifAdminStatus ifOperStatus      ifLastChange
-----
 1      eth0             Up             Up                 00:00:03
 2      eth1             Up             Down                00:00:00
 3      bri0             Up             Swapped out        00:00:43
 4      eth2             Up             Swapped out        00:00:42
-----

Interface name summary

Interface Full name
-----
asyn0    asyn0
asyn1    asyn1
eth0     eth0
eth1     eth1
-----

```

Figure 14: Example output from the SHOW INTERFACE command for a specific interface.

```

Interface..... bri0
ifIndex..... 3
ifMTU..... 1712
ifSpeed..... 144000
ifAdminStatus..... Up
ifOperStatus..... Swapped out
ifLinkUpDownTrapEnable... Disabled
TrapLimit..... 20

Interface Counters

ifInOctets ..... 52190      ifOutOctets ..... 52190
ifInUcastPkts ..... 3070    ifOutUcastPkts ..... 3071
ifInNUcastPkts ..... 0      ifOutNUcastPkts ..... 0
ifInDiscards ..... 0        ifOutDiscards ..... 0
ifInErrors ..... 0          ifOutErrors ..... 0

```

PIC Testing and Verification

There are several ways to check that a PIC is installed and operating correctly. First, check that the switch or router has recognised the card. Turn on the switch or router and enter the command:

```
SHOW SYSTEM
```

to display system information (Figure 15 on page 27).

Figure 15: Example output from the SHOW SYSTEM command for a switch or router with PICs installed.

```
Router System Status                               Time 17:10:06 Date 25-Sep-2000.
Board      ID  Bay Board Name                               Rev    Serial number
-----
Base       62      AR720                               M1-0   6845218
IC Module  40   0  AR022 PIC Eth                               M2-0   6844595
IC Module  38   1  AR023 PIC Sync                             M1-1   6844715
MAC        67      AR012 CMAC                             M2-0   33636409
-----
Memory -   DRAM : 16384 kB   FLASH : 4096 kB
-----
SysDescription
CentreCOM AR720 version 1.8.1-00 08-Sep-1999
SysContact
David Johns, ext 8331
SysLocation
Laboratory, First Floor, Head Office Building
SysName
LAB
SysUpTime
250074 ( 00:41:40 )
Software Version: 1.8.1-00 08-Sep-1999
Release Version : 1.8.1-00 08-Sep-1999
Patch Installed : NONE
Territory      : europe
Help File      : help.hlp

Boot configuration file: load.cfg (exists)
Current configuration: load.cfg
Security Mode  : Disabled

Warning (248283): No patches found.
```

The first part of the display shows details of cards installed in the switch or router. There should be one entry for the switch's or router's base card and one entry for each PIC installed. Both the serial number and the part name should also be displayed.

If there is no entry for a PIC, then the boot process has not correctly detected the presence of the PIC. The most likely cause is that the connector on the PIC is not plugged into the PIC slot on the base card correctly. Repeat the installation process, paying particular attention to Steps 9 and 10 of the *Port Interface Card Quick Install Guide*. Use the SHOW SYSTEM command from the Operation chapter of the Software Reference or Reference Manual for your switch or router. If the display is still not correct, contact your Authorised Allied Telesyn distributor or reseller.



If you have any difficulty with the PIC at any time, contact your Authorised Allied Telesyn distributor or reseller and quote the serial numbers of both the base CPU card and the PIC. These numbers are printed on the cards, and can also be read using the SHOW SYSTEM command. It's a good idea to record this information for later reference.

The functionality of all PICs except the AT-AR026 can be checked using the Test Facility software that is built-in to the switch or router, or alternatively, the PIC's interfaces can be attached to known working networks and devices.



AT-AR026 PICs do not support the Allied Ware Diagnostic or Test Facility modules.



AT-AR026 PICs include a switch chip that switches independently of the switch, router, or NSM that the PIC is installed in. The SHOW INTERFACE command will show each correctly installed AT-AR026 as a single interface (the PIC connector). The 10/100 'front side' Ethernet ports will not be shown.

For PIC testing using existing networks and devices, the interfaces must be configured correctly to route packets. For more information about configuring interfaces, see the relevant chapter in your switch's Software Reference or the relevant chapter in your router's Reference Manual.

Using a terminal to verify operation

PICs with asynchronous ports can be tested using a terminal set to:

- 9600 bps
- 8 data bits
- 1 stop bit
- No parity
- Hardware flow control

Verify that the terminal functions correctly by connecting it to the management port (the Console Port or RS-232 Terminal Port) and then pressing [Return] several times until the prompt is displayed.

Then connect the terminal to one of the PIC's ports, and press [Return] several times. If the prompt is displayed, the port is functioning correctly. If the prompt is not displayed, the most likely cause is that the PIC's ports are set to different operational parameters. This can be verified by reconnecting the terminal to the management port and using the command:

```
SHOW PORT=ALL
```

Compare the PIC's port settings with the settings for the management port. Any differences should be corrected by modifying the PIC card settings using the SHOW ASYN command (from the *Interfaces* chapter of the Software Reference or Reference Manual for your switch or router). Reconnect the terminal to one of the PIC's ports and press [Return] several times. If the prompt is still not displayed, contact your Authorised Allied Telesyn distributor or reseller.

Using the test facility to verify operation

The built-in Test Facility software provides the best method to properly verify the correct operation of PIC interfaces. For more information on using the Test Facility, see “Test Facility” on page 43.

In order for the Test Facility to operate, on some interfaces, you will need to install a loopback plug or cable. See Table 16 on page 29 for a list of interface types and their loopback requirements. The “Loopback Plugs for Testing Interfaces” section beginning on page 41 outlines how to construct a loopback plug or cable.

To run the Test Facility for a specific interface, use the command:

```
ENABLE TEST INTERFACE={ ALL | BASE | EXPANSION | ETH $n$  | SYN $n$  | PORT $n$  |
  BRI $n$  | PRI $n$  | ENGINE | MAC | MAC0 | MAC1 | MAC2 }
```

where n is the interface number. To run the Test Facility for all interfaces on a PIC, use the command:

```
ENABLE TEST INTERFACE=EXP
```

The tests will run for 4 minutes.

Table 16: Loopback plugs, cables and devices required for testing PIC interfaces.

Switch Interface	Loopback plug, cable or test device required
Asynchronous	RJ-45 asynchronous loopback plug. Use one plug to individually test each port one by one, or all ports can be tested simultaneously if sufficient loopback plugs are available.
Ethernet LAN (AT-AR022 ETH PIC only)	Ethernet loopback plug. The Test Facility software will detect (by looking for traffic) if the transceiver is connected to a working LAN. If it detects traffic, the transceiver test will abort.
Basic Rate ISDN	The BRI PIC does not support the NT mode, so a loopback plug can not be used. Internal loopback tests can be run without a loopback plug. For more complete testing, connect the BRI interface to an external ISDN test device and use the ENABLE BRI CTEST command and the DISABLE BRI CTEST command from the <i>Integrated Services Digital Network (ISDN)</i> chapter (of the Software Reference or Reference Manual for your switch or router) to execute conformance loopback tests and to generate packets.
Primary Rate ISDN	PRI loopback plug.
Synchronous	External test unit. This can be purchased through authorised Allied Telesyn distributors or resellers. It contains custom-built electronics to allow all interface types (RS-232, V.35 and X.21) to be automatically tested using a single cable.

If the tests are run without a loopback plug, they will stop after about 30 seconds and display a warning message to that effect. To view the results of the tests at any time, use the command:

```
SHOW TEST
```

The status of the tests for each interface will be shown in the right-most column of the output. For more information on the meanings of the other figures, see the *Test Facility* chapter of the Software Reference or Reference Manual for your switch or router.

If you are unsure about running the Test Facility, or have difficulty evaluating the results, contact your Authorised Allied Telesyn distributor or reseller.

Cables and Loopback Plugs for PICs

This section describes how to make cables for connecting PIC interfaces to networks, terminals, printers and other devices. How to make loopback plugs for testing PIC interfaces is also described.

Transition Cables for the AT-AR023 PIC

The synchronous port on the AT-AR023 SYN PIC uses an AMPLIMITE 50-way connector wired as a universal connector to support RS-232/V.28, V.35 and X.21 interface standards in DTE and DCE modes.

A transition cable is required to convert the AMPLIMITE to the correct physical interface for the standard required (e.g. DB15 for X.21). The transition cable can be ordered from your distributor or reseller, or you can construct your own cable by following the wiring diagrams in this section.

The transition cable does more than simply change the physical connector. The switch or router hardware 'reads' the cable type from the AMPLIMITE plug and enables or disables the internal driver electronics as required. To function correctly, the cables must be identical to the cables described in this section.



The DCE cable type reverses the direction of the data lines as well as the clock lines. This cable is intended to be used when the switch or router supplies the clock for an attached device. This is commonly used when the switch or router is connected to the synchronous port of another switch, router, or host, without using an intermediate modem or NTU (Network Terminating Unit). Therefore, the DCE cable must only be connected to a port which is set to generate the clock. The Interfaces chapter of the Software Reference or Reference Manual for your switch or router has more information. The AMPLIMITE connector supports both DTE and DCE modes for all three physical standards.



Please pay particular attention to V.35 connections. The switch or router interface is fully compliant to V.35 but many DCE (DSU/CSU) devices are not. Because of the low signal levels used for V.35 (500mV point-to-point), issues such as ground loops and excess cable length become more important than with X.21. In particular, some DCE devices connect the cable ground to chassis or safety ground. This can create an earth loop condition through the shield wire of the V.35 interface. The symptom of this condition is unexpectedly high received packet errors (CRC, Abort etc.) as seen in the output of the `SHOW SYN=n COUNT` command. In these cases the suggested remedy is to break the earth loop by disconnecting (and isolating) pin A inside the M34 connector. This action does not compromise the safety of the product in any way.

The transition cable can be changed at any time. It is not necessary to power-down the switch or router.



Good quality data grade cables should be used for all cables. All transition cables must be made from paired cable with an overall foil shield. Metalised backshells must also be used. Poor quality cables will limit the maximum speed or the maximum length of the cable, or both.



It is very important that the cables do not degrade the EMC emission standards of the switch, router, or PIC (e.g., FCC, CISPR). The cable foil shield must be connected to the AMPLIMITE metalised backshell with a 360 degree ferrule. In addition, on specified cables, a clip-on cable ferrite must be attached to the cable at the AMPLIMITE end, no more than 25 mm from the rear of the backshell of the AMPLIMITE connector. Contact your Authorised Allied Telesyn distributor or reseller for a list of approved ferrites.

Table 17 on page 31 lists the wiring diagrams to follow when constructing transition cables for each physical interface standard.

Table 17: Transition cable pin wiring diagrams for the AT-AR023 SYN PIC.

Physical Interface Standard	Pin Wiring Diagram
RS-232 DTE	Figure 16 on page 32
RS-232 DCE	Figure 17 on page 33
V.35 DTE	Figure 18 on page 34
V.35 DCE	Figure 19 on page 35
X.21 DTE	Figure 20 on page 36
X.21 DCE	Figure 21 on page 37

Figure 16: Pin wiring diagram for an RS-232 DTE transition cable to an AMPLIMITE 50-way connector.

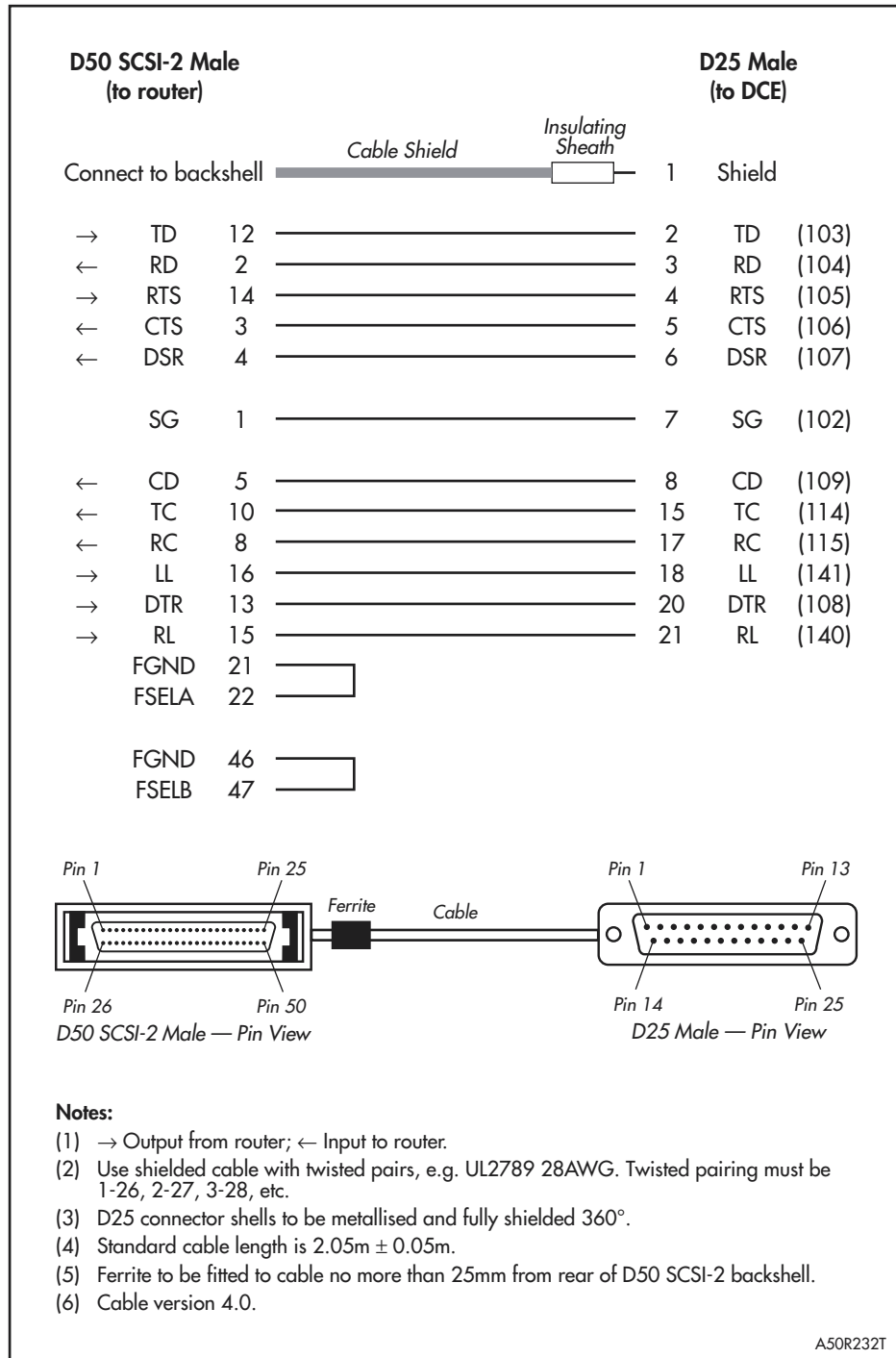

Figure 17: Pin wiring diagram for an RS-232 DCE transition cable to an AMPLIMITE 50-way connector.

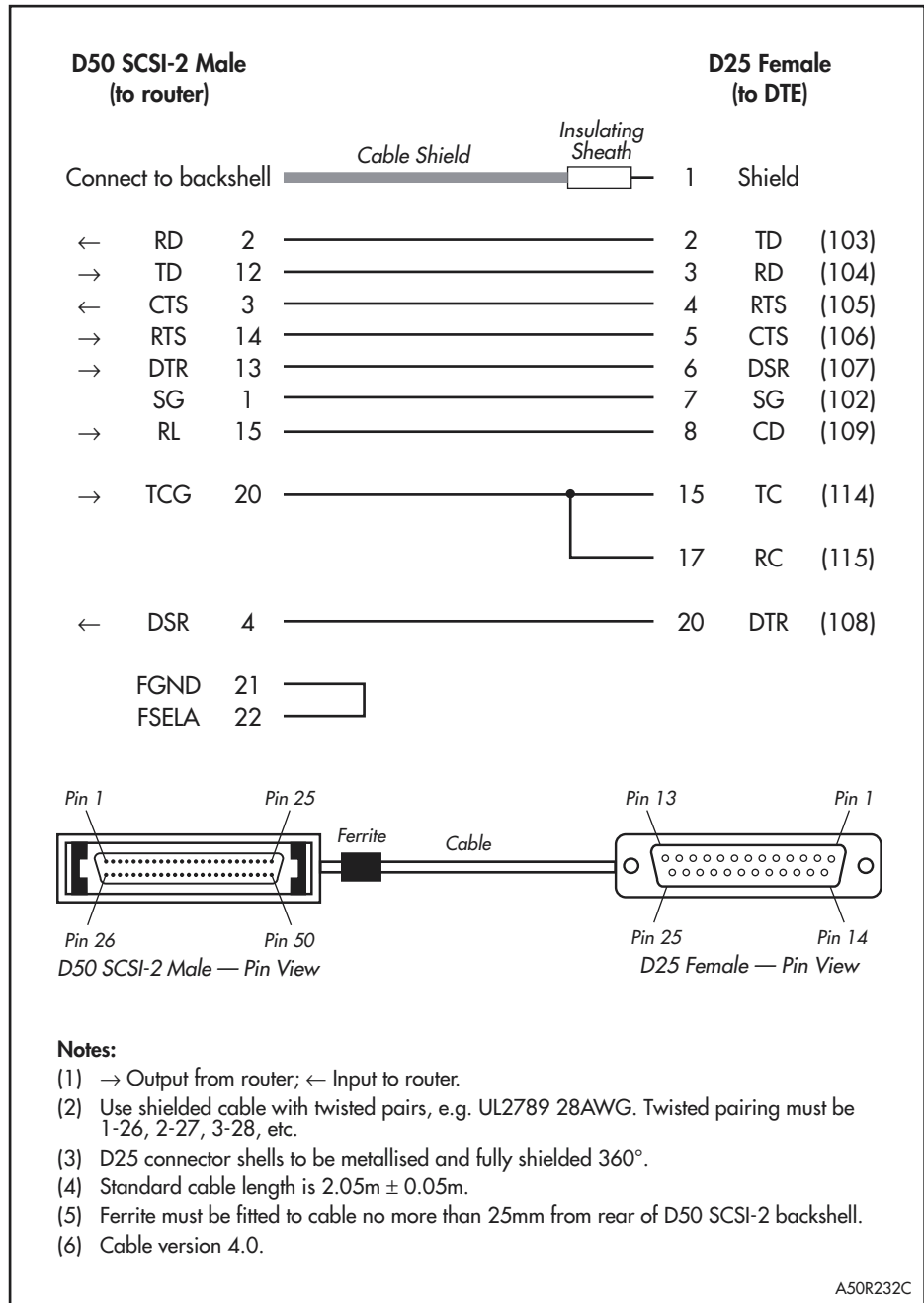

Figure 18: Pin wiring diagram for a V.35 DTE transition cable to an AMPLIMITE 50-way connector.

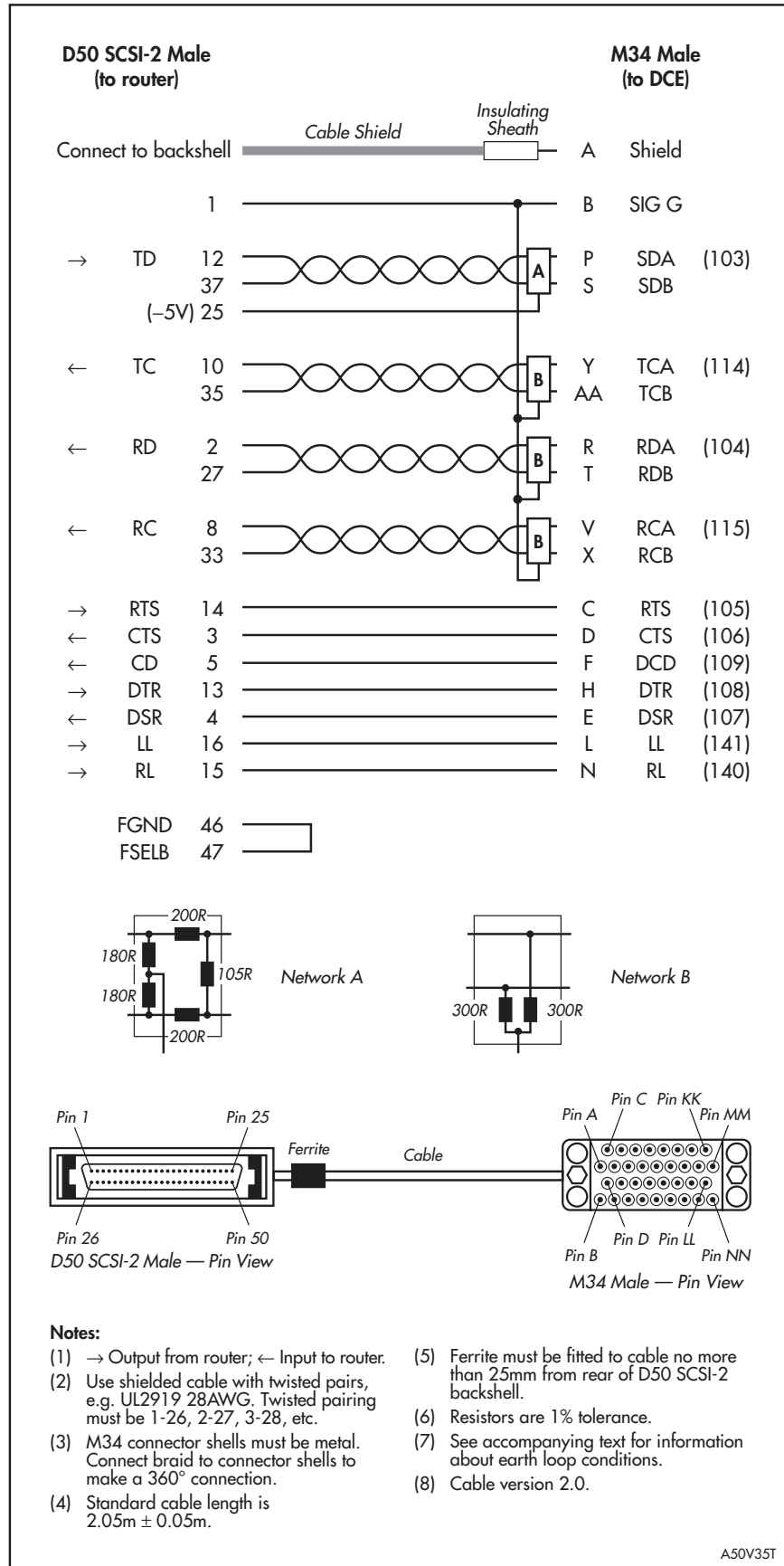

Figure 19: Pin wiring diagram for a V.35 DCE transition cable to an AMPLIMITE 50-way connector.

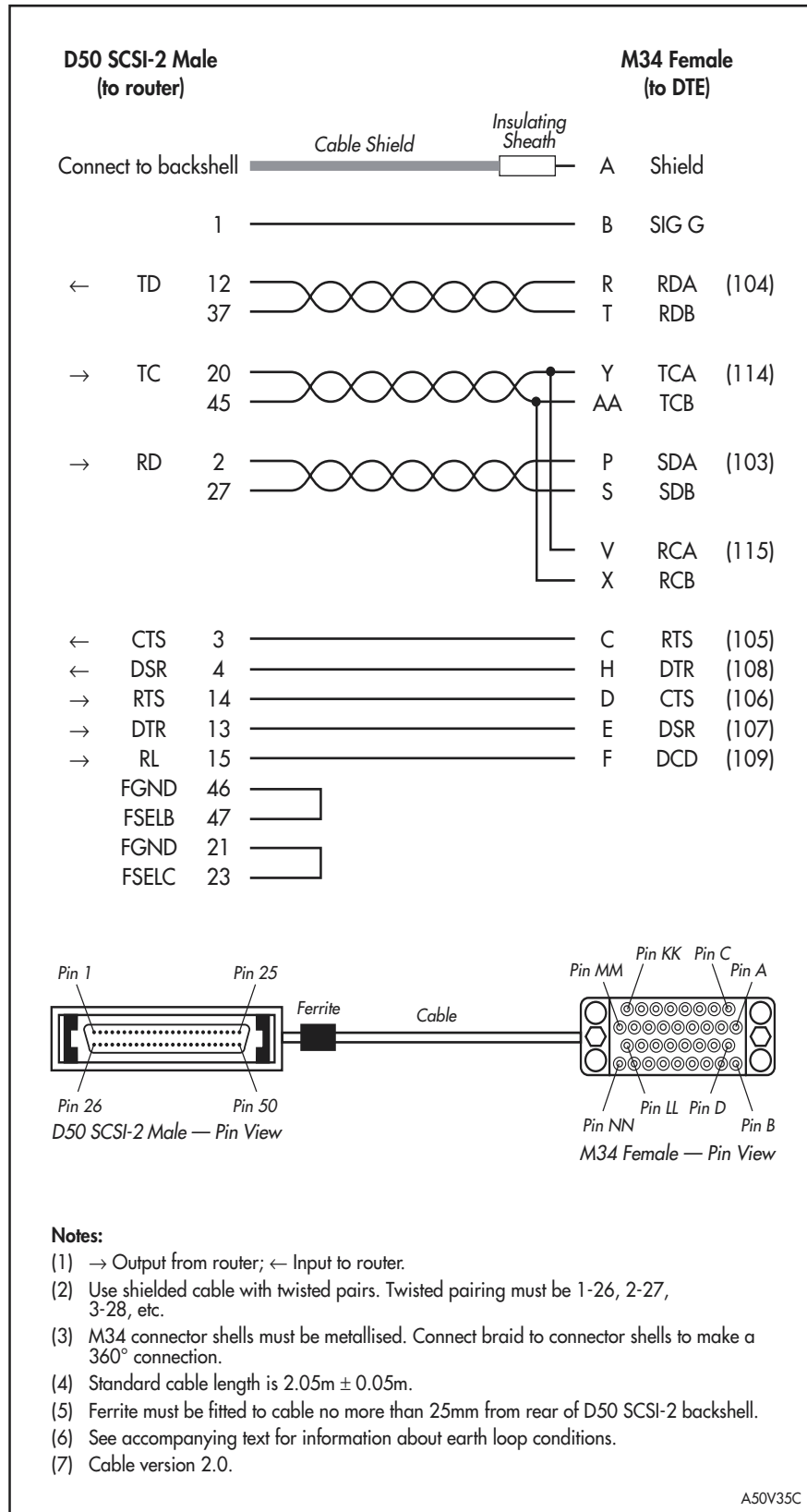

Figure 20: Pin wiring diagram for an X.21 DTE transition cable to an AMPLIMITE 50-way connector.

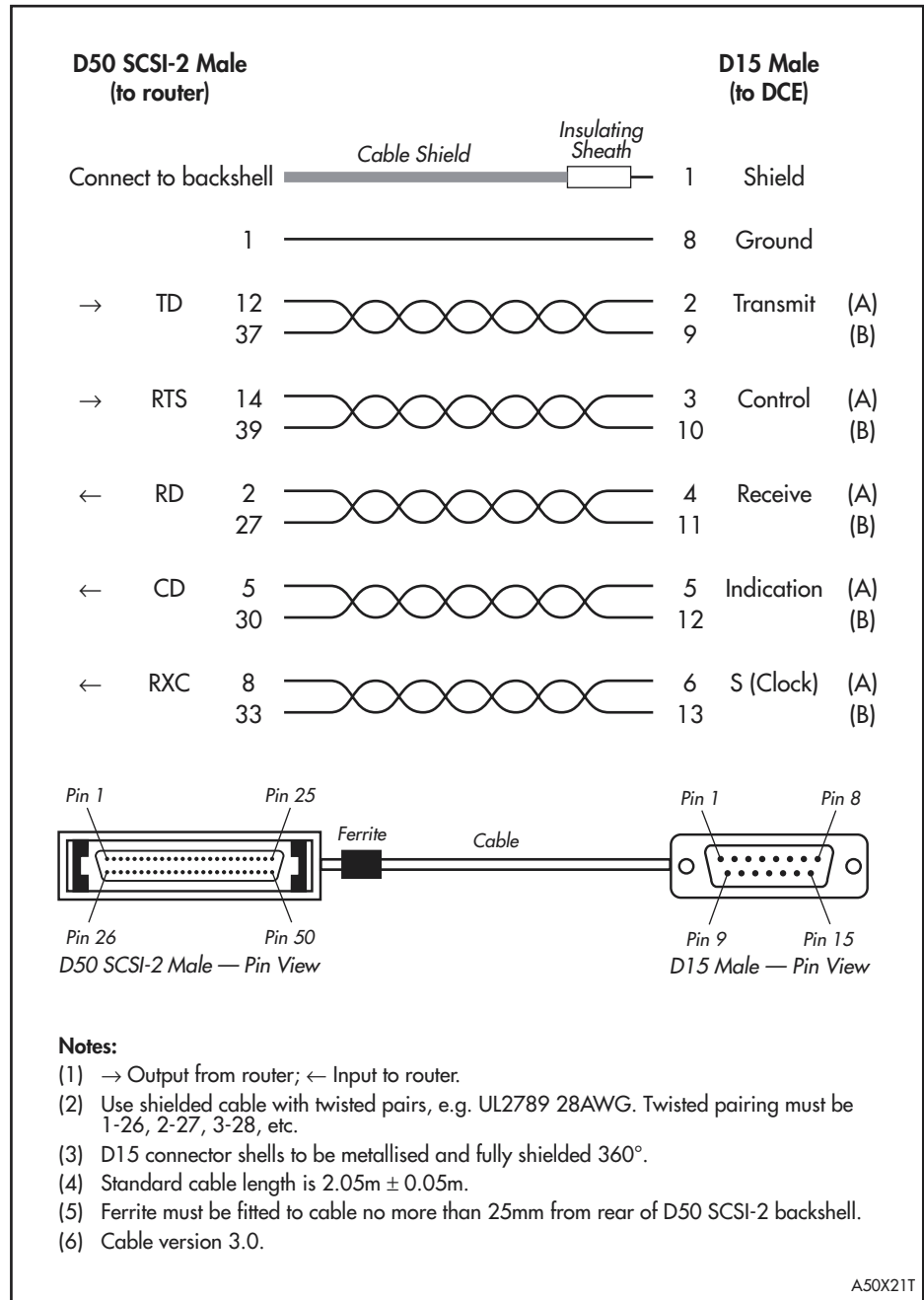
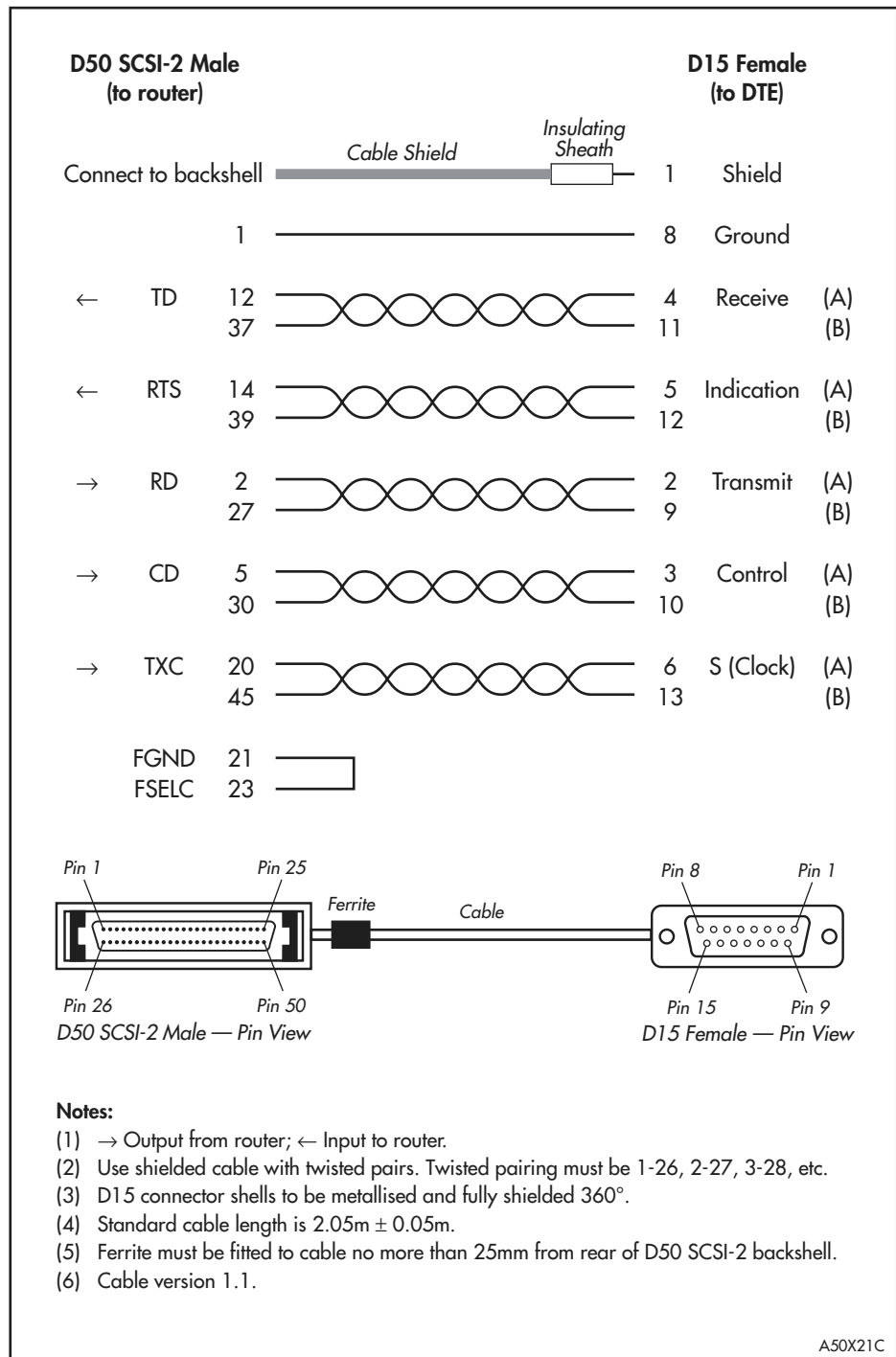

Figure 21: Pin wiring diagram for an X.21 DCE transition cable to an AMPLIMITE 50-way connector.



ISDN Interface Cables

PICs provide two ISDN interface options. The AT-AR021(S) BRI-S/T and AT-AR021(U) BRI-U PICs provide Basic Rate ISDN interfaces, while the AT-AR020 PRI E1/T1 provides a Primary Rate ISDN interface.

Figure 22 on page 38 shows how to wire a cable to connect a Basic Rate Interface (BRI) to the ISDN network terminating equipment (NT).

Figure 22: Pin wiring diagram for an ISDN Basic Rate straight-through Interface cable.

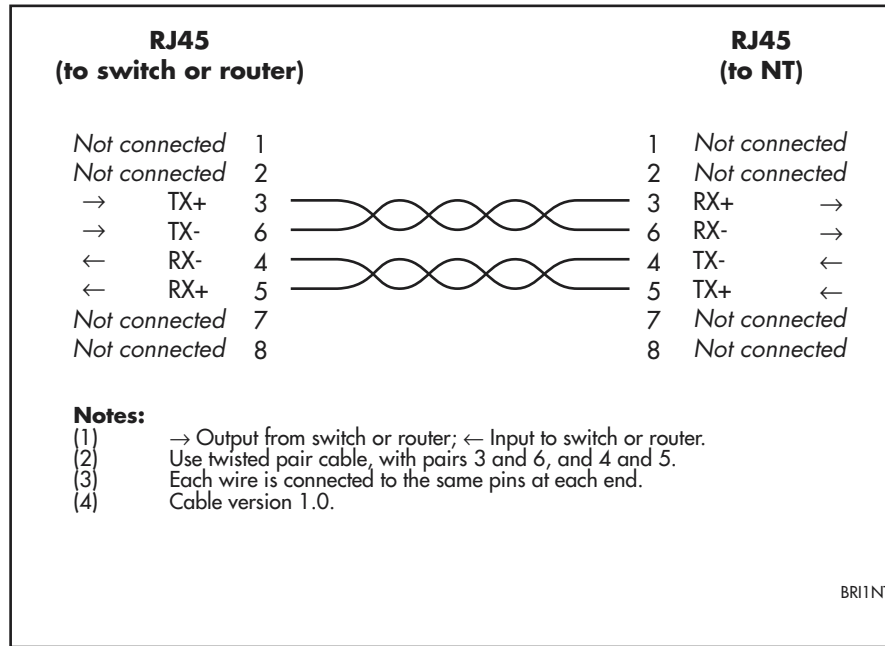
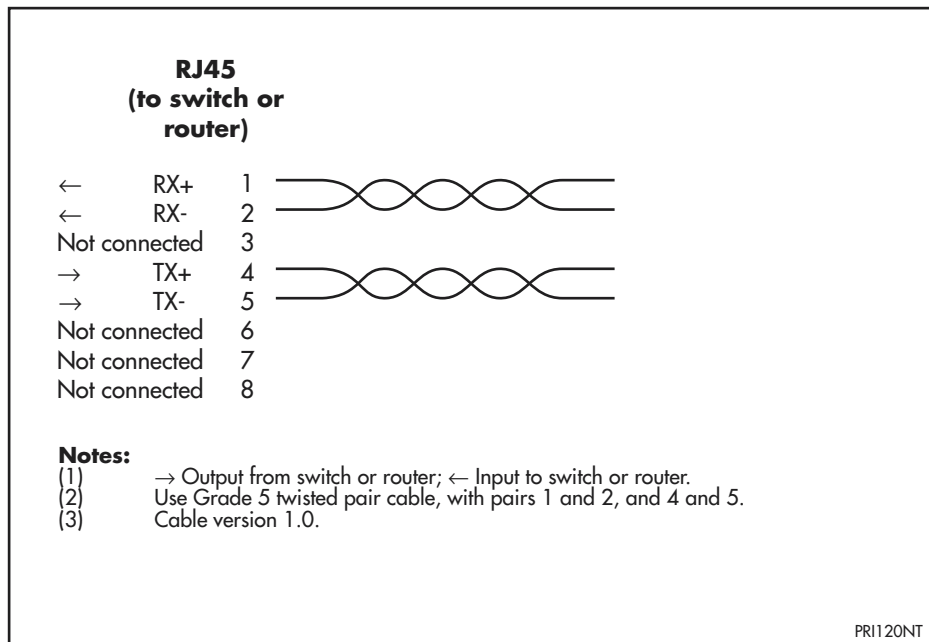

Figure 23 on page 38 shows how to wire a cable to connect to the RJ-45 connector of a Primary Rate Interface (PRI). Currently there is no accepted standard for the connector at the network termination end, so only the switch end of the cable is shown. Consult your ISDN service provider for more information.

Figure 23: Pin wiring diagram for an ISDN Primary Rate Interface (120Ω) cable.



BT Adaptor Cable for the AT-AR027 PIC

The AT-AR027 VoIP-FXS PIC uses a standard R-J11 connector. To connect telephones with a BT-style connector, use an RJ-11 to BT adaptor cable (Figure 24 on page 39).

Figure 24: Pin wiring diagram for an RJ-11 to BT adaptor cable.

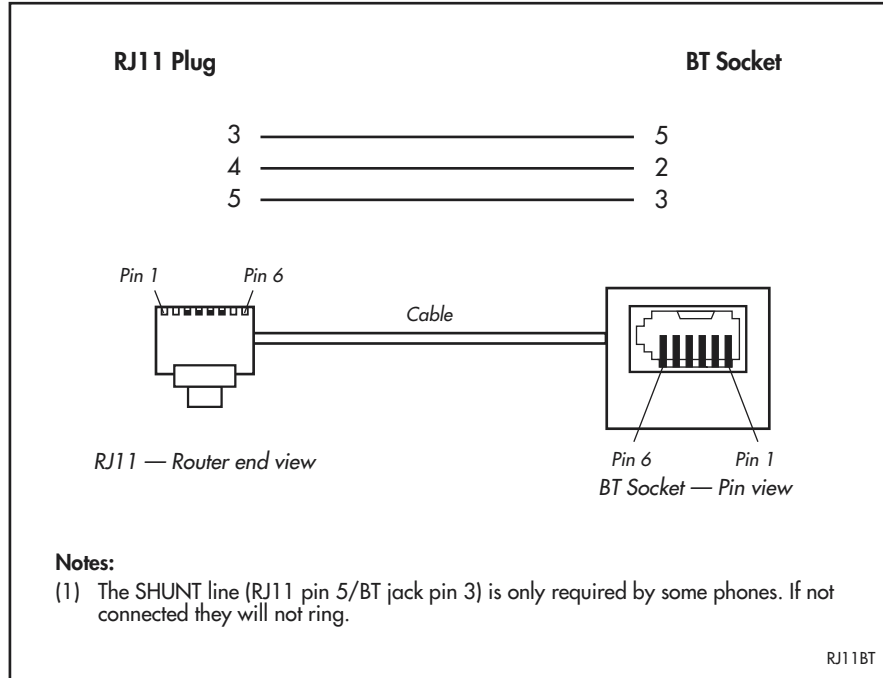

Terminal and Modem Cables

Figure 25 on page 40 shows how to wire a cable to connect a standard VT100-compatible terminal to an asynchronous (RJ-45) port. Some terminals are fitted with a DB25 female connector rather than a DB25 male connector. In this case the cable should be fitted with a DB25 male connector.

Figure 26 on page 40 shows how to wire a cable to connect an asynchronous (RJ-45) port to a modem.

An alternative method, for both terminal and modem cables, is to wire an RJ-45 patch cord (a straight pin-to-pin cable with RJ-45 connectors on both ends) and then use an RJ-45-to-DB25 adaptor wired internally as a crossed cable. These adaptors are available in both DB25 female and male versions from data cabling suppliers, and are supplied with wires terminated on the RJ-45 socket and pins on the free ends. The pins are inserted into the appropriate positions in the DB25 shell.

Figure 27 on page 41 shows how to wire a cable to connect an asynchronous (RJ-45) port on the switch to the COM port on a Macintosh.

Figure 25: Pin wiring diagram for a standard RJ-45 terminal cable.

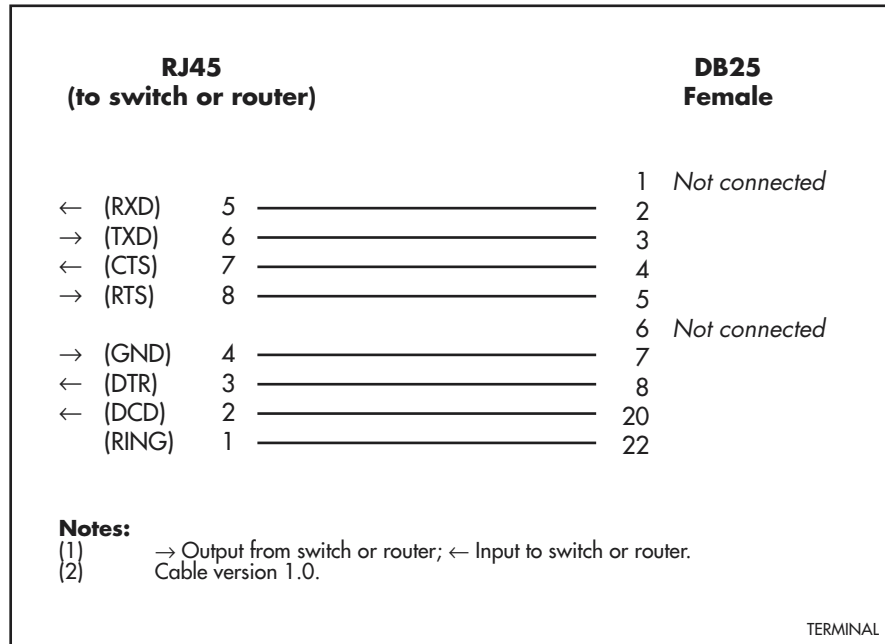

Figure 26: Pin wiring diagram for a standard modem cable.

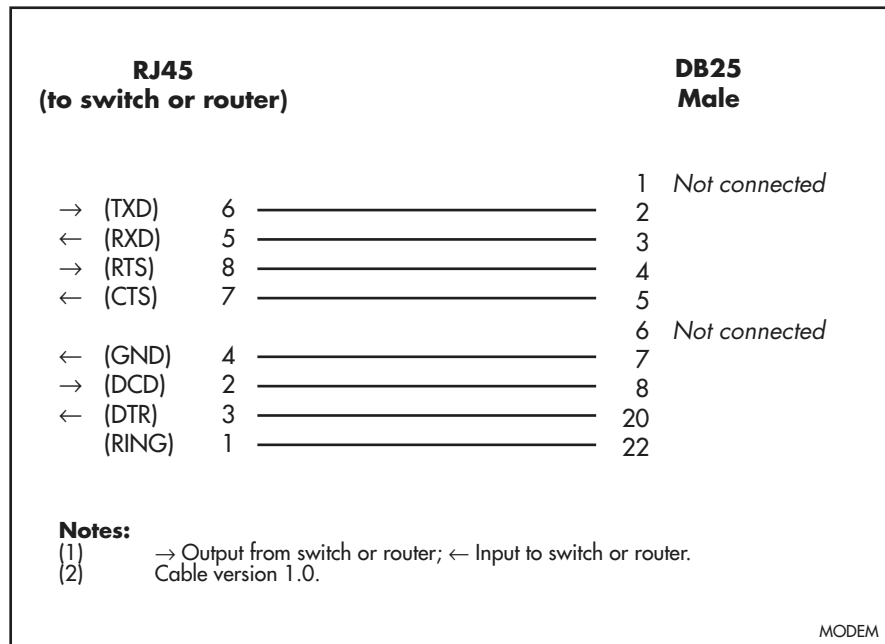
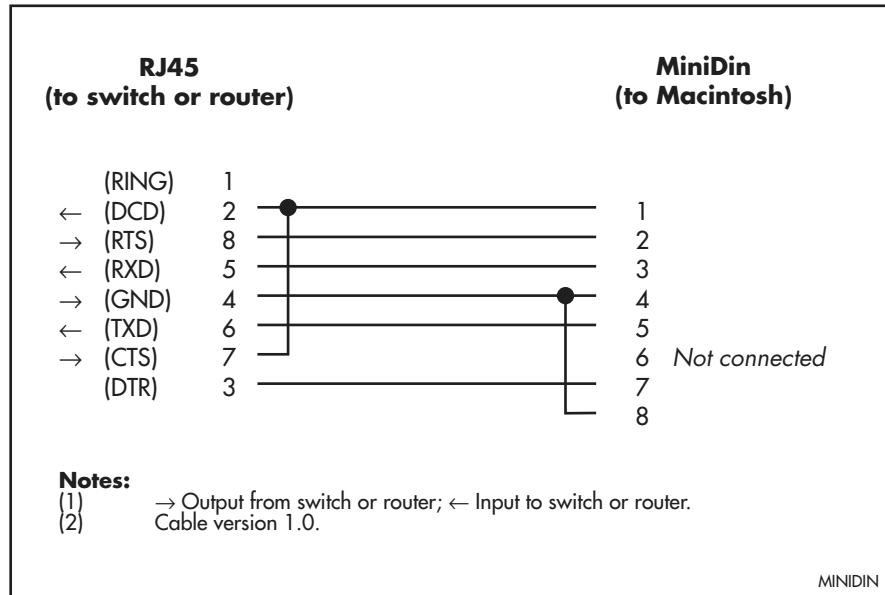

Figure 27: Pin wiring diagram for a Macintosh serial cable.



Loopback Plugs for Testing Interfaces

Loopback plugs are used in conjunction with the Test Facility software to test the physical interfaces on all PICs except the AT-AR026 and AT-AR027 (see the “Test Facility” section beginning on page 43 of this Reference, and the *Test Facility* chapter of the *Software Reference Manual* or *Reference Manual*).

The purpose of a loopback plug is to connect the output pins on the interface to the input pins so that any data transmitted over the interface is looped back (hence *loopback* plug) and received at the same interface.

On interfaces with control signals, these are also looped back. The data received on the interface is compared with the data transmitted on the interface to determine whether or not the interface is functioning correctly. In order to produce a comprehensive test report for the interface being tested, most tests performed by the Test Facility require a loopback plug to be inserted.

Some interfaces (e.g., synchronous ports) require a specially built external testing device (available from your Authorised Allied Telesyn distributor or reseller) to be used in conjunction with the Test Facility.

The BRI interfaces do not require loopback plugs. The Test Facility will perform an internal loopback test on these interfaces.

Table 18 on page 41 lists the loopback plug wiring diagrams for each PIC interface type.

Table 18: Loopback plug pin wiring diagrams.

Physical Interface	Loopback Method/Pin Wiring Diagram
RJ-45 asynchronous interface	Figure 28 on page 42
Ethernet AUI interface	Figure 29 on page 42
Ethernet TP interface	Figure 30 on page 42
Basic Rate ISDN S/T and U interfaces	No loopback plug required
Primary Rate interface	Figure 31 on page 43

Figure 28: RJ-45 loopback plug for testing asynchronous interfaces.

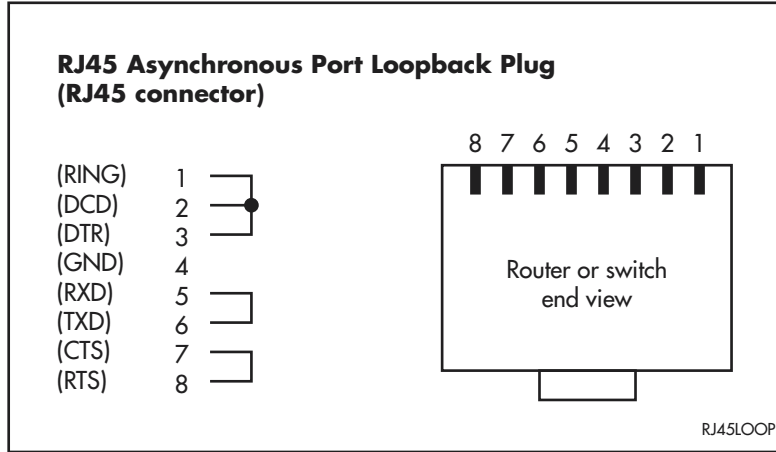

Figure 29: Ethernet AUI loopback plug.

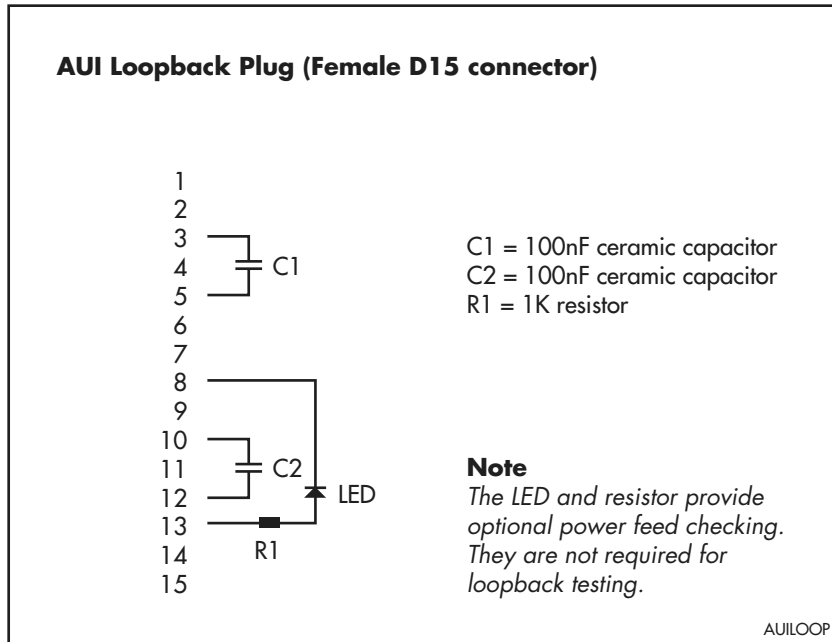

Figure 30: Ethernet twisted pair (TP) loopback plug.

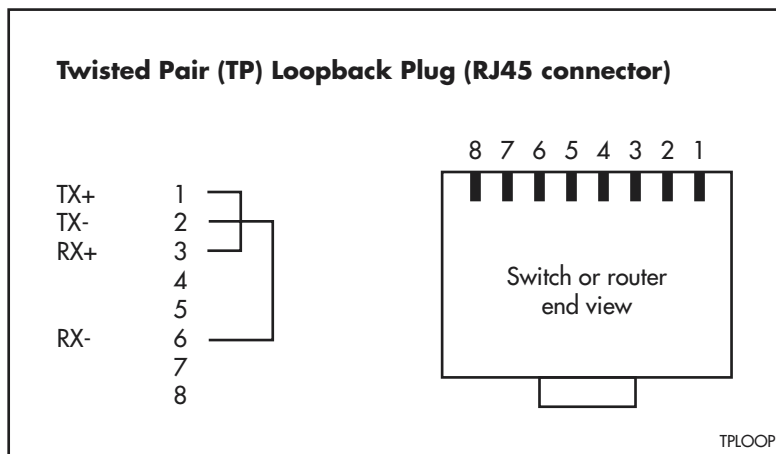
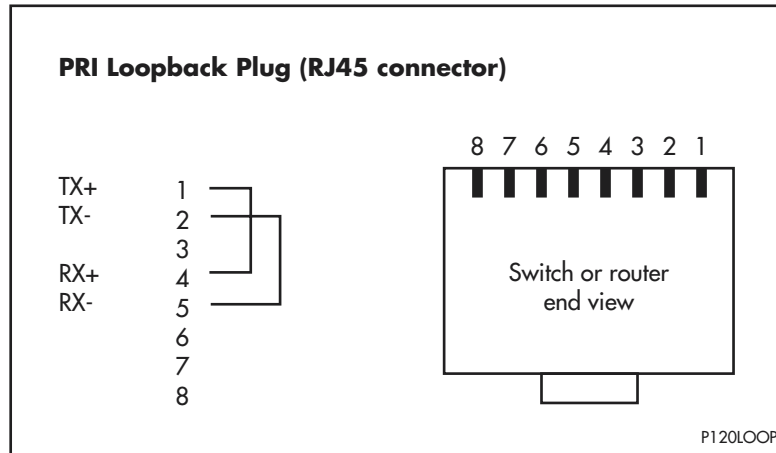

Figure 31: Primary Rate ISDN loopback plug.



Test Facility

The Test Facility is designed to test physical interfaces on all PICs except the AT-AR026. Testing can be performed while the switch or router is operational, but any interfaces being tested are dedicated to the Test Facility. The Test Facility can be thought of as a specialised interface module like PPP or Frame Relay.



AT-AR026 PICs do not support the Allied Ware Diagnostic or Test Facility modules.

The Test Facility is built into all switch and router software. For more information on the Test Facility's operation, see the *Test Facility* chapter of the Software Reference or Reference Manual for your switch or router.

Allied Telesyn PICs support a wide range of interface types, including Ethernet, asynchronous, synchronous, Basic Rate ISDN and Primary Rate ISDN. Each interface type can be tested independently using the Test Facility software. The following examples show how to test specific interfaces.

Test results are displayed with the command:

```
SHOW TEST
```

which produces a display like that shown in Figure 32 on page 44.

Figure 32: Example output from the SHOW TEST command.

Board	ID	Bay	Board Name	Rev	Serial number
Base	62		AR720	M1-0	6845181
IC Module	38	0	AR023 PIC Sync	M1-1	5917086
IC Module	44	1	AR025 PIC E1 PRI	M1-0	6843626
MAC	68		AR011 ECMAC	P1-1	6804365

Interface	State	Result	Type	Duration (minutes)	Details Data(%OK)	Control
eth0	halted	* Active LAN	trans	< 1	BAD (0.0)	-
			TP	0	-	-
			ENDEC	0	-	-
			MAC	0	-	-
port0	complete	good	-	1000	good(99.0)	good
port1	complete	good	-	1000	good(99.0)	good
syn0	testing	wait continuous	RS-232dte	355	good(100.0)	good
			dce	355	good(100.0)	good
			X.21 dte	354	good(100.0)	good
			dce	0	-	-
			V.35 dte	354	good(100.0)	good
			dce	0	-	-
PRI0	halted		-	< 1	BAD (0.0)	-
mac0	complete	good	DES	4	good(100.0)	-
mac1	complete	good	STAC	4	good(100.0)	-
mac2	complete	good	ALL	4	good(100.0)	-

Asynchronous Interface Tests

The asynchronous interfaces require a loopback plug to be installed before the test will operate. See “Cables and Loopback Plugs for PICs” on page 30 for details of how to make a loopback plug. To start an asynchronous interface test, use the command:

```
ENABLE TEST INT=PORTn
```

where *n* is the interface number. The test will run for 4 minutes. Use the SHOW TEST command to observe the test progress.

WAN Port Tests

An external tester is required to fully test synchronous interfaces. External testers are available from authorised Allied Telesyn distributors or resellers. To start a WAN interface test, use the command:

```
ENABLE TEST INT=SYNn
```

or

```
ENABLE TEST INT=BRIn
```

where *n* is the WAN interface number. The test will run for 4 minutes. Use the SHOW TEST command to observe the test progress.



If a test fails, please contact your Authorised Allied Telesyn distributor or reseller.

For more information on using the Test Facility, see the Software Reference or Reference Manual for your switch or router.

Troubleshooting

This section provides information on how to detect and resolve problems with PICs.

Other sources of troubleshooting information are:

- www.alliedtelesyn.co.nz
- The Test Facility section on page 43.
- The user documentation for your switch or router.

Performing the following tasks will eliminate the most common faults.

1. Check that the PIC is correctly installed. See the *Port Interface Card Quick Install Guide* for a step by step guide to installing PICs.
2. Make sure the power cord is securely connected to the switch or router.
3. Check that the power supply voltage to the switch or router is stable.
4. Check that the correct data cables are being used and that their connections are secure.
5. Make sure that other network devices are working properly.
6. Use the SHOW INSTALL command to check that the latest software release is loaded. The Software Reference or Reference Manual for your switch or router has more information about obtaining and installing the latest software release.
7. If the switch is malfunctioning, reboot it by pressing the recessed Reset button or entering the command RESTART REBOOT. Alternatively, power OFF and ON the switch by disconnecting and reconnecting the main power supply (including, if connected, the RPS power).

Contacting Us

With locations covering all of the established markets in North America, Latin America and Europe, Allied Telesyn provides localized sales and technical support worldwide. To find our representative nearest you, visit Allied Telesyn on the web at: <http://www.alliedtelesyn.com>.