

# NETWORK SERVICE MODULE

## HARDWARE REFERENCE

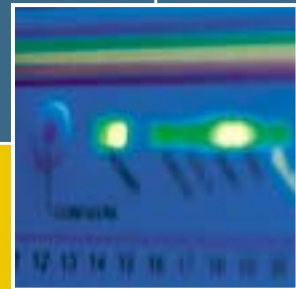
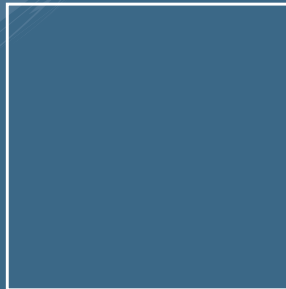
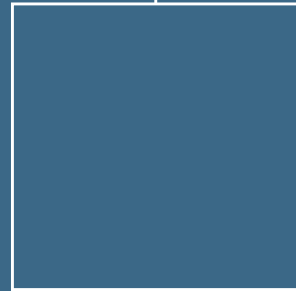

Network Service Module Hardware Reference  
Document Number C613-03022-00 REV E.

Copyright © 1999-2001 Allied Telesyn International, Corp.  
19800 North Creek Parkway, Suite 200, Bothell, WA 98011, USA.

All rights reserved. No part of this publication may be reproduced without prior written permission from Allied Telesyn.

Allied Telesyn International, Corp. reserves the right to make changes in specifications and other information contained in this document without prior written notice. The information provided herein is subject to change without notice. In no event shall Allied Telesyn be liable for any incidental, special, indirect, or consequential damages whatsoever, including but not limited to lost profits, arising out of or related to this manual or the information contained herein, even if Allied Telesyn has been advised of, known, or should have known, the possibility of such damages.

All trademarks are the property of their respective owners.

# Contents

---

Models Covered By This Reference .....	4
Why You Should Read This Reference .....	4
Where To Find More Information .....	4
Compatible Base Units .....	5
What NSMs do .....	5
Hardware Description .....	5
Hardware Features Common To All NSM Models .....	5
Hardware Features For Specific NSM Models .....	6
AT-AR040 NSM .....	6
AT-AR041 and AT-AR042 NSMs .....	7
Basic Rate ISDN Interfaces .....	8
ISDN S/T Interface Cables .....	10
Testing a BRI NSM .....	10
Hot Swapping .....	12
Hot Swapping the AR040 NSM with PICs .....	13
How to Hot Swap an NSM .....	13
Behaviour of Hot Swapped Interfaces .....	15
Troubleshooting .....	17
Fault Indicators and What They Mean .....	17
Contacting Us .....	21

---

## Models Covered By This Reference

---

This Hardware Reference includes information on the following models:

- AT-AR040
- AT-AR041
- AT-AR042

The latest Hardware Reference can be found at [www.alliedtelesyn.co.nz/support/support.html](http://www.alliedtelesyn.co.nz/support/support.html).

---

## Why You Should Read This Reference

---

This Reference has been developed to familiarise you with the hardware features of Network Service Modules (NSMs). The Reference provides information that will assist you with the process of managing and servicing an NSM. For information about installing an NSM, see the *Network Service Module Quick Install Guide*.

The Reference also introduces Port Interface Card (PIC) expansion options. Detailed information on PICs can be found in the *Port Interface Card Hardware Reference*. This Reference can be found on the CD-ROM bundled with every switch or router, or at [www.alliedtelesyn.co.nz/support/support.html](http://www.alliedtelesyn.co.nz/support/support.html).



---

*This Reference does not cover software configuration or physical installation procedures. For information on software, refer to the Installation Guide or Reference Manual for your switch or router. For information on installing an NSM, refer to the Network Service Module Quick Install Guide. These guides and manuals can be found on the CD-ROM bundled with every switch or router, or at [www.alliedtelesyn.co.nz/support/support.html](http://www.alliedtelesyn.co.nz/support/support.html).*

---

---

## Where To Find More Information

---

There are several sources of further information:

- The *Network Service Module Quick Install Guide*, which outlines the procedure for installing NSMs.
- The Installation Guides or Reference Manuals for your switch or router, which provide information on related hardware and software features.
- The *Port Interface Card Quick Install Guide*, which outlines the procedure for installing PICs; and the *Port Interface Card Hardware Reference*, which provides detailed information on PICs.

All of these documents can be found on the CD-ROM bundled with your switch or router, or at [www.alliedtelesyn.co.nz/support/support.html](http://www.alliedtelesyn.co.nz/support/support.html).

---

## Compatible Base Units

---

NSMs can be installed in the following switches, switching routers, and routers:

### Rapier Switches

- Rapier 8/8MT
- Rapier 8/8SC
- Rapier 16F-FX/MT-RJ
- Rapier 16F-FX/SC
- Rapier 24

### Rapier *i* Switches

- Rapier 24*i*

### AR800 Modular Switching Routers

- AR816F-FX/MT-RJ
- AR816F-FX/SC
- AR824

### Routers

- AR740 Family

---

## What NSMs do

---

NSMs are expansion options for those switch and router models that have an NSM bay. NSMs slot into a base-unit switch or router and either directly provide additional WAN interfaces, or provide multiple slots where additional WAN interfaces can be added.

---

## Hardware Description

---

This section provides an overview of NSM hardware features. Hardware descriptions for switches, routers, and PICs can be found in their respective Installation Guides or Reference Manuals.

### Hardware Features Common To All NSM Models

These hardware specifications apply to all NSM models. For model specific information, see “Hardware Features For Specific NSM Models” on page 6.

#### Environmental Conditions

- Operating temperature range: 0 to 40° C (32 to 104° F)
- Storage temperature range: -25 to 70° C (-13 to 158° F)
- Relative humidity range: 5 to 95% non-condensing

## Regulatory Standards

### AT-AR040

- EMC: CISPR22 class A, FCC class A, and VCCI class I
- Immunity testing to EN50082 levels 2 (ESD), 3 (susceptibility), 4 (fast transients), 5 (power surge), and 6 (RF immunity)
- Safety: UL1950, CSA22.2, EN60950

### AT-AR041 and AT-AR042

- EMC: CISPR22 class A, FCC class A, and VCCI class I
- Immunity testing to EN50082 levels 2 (ESD), 3 (susceptibility), 4 (fast transients), 5 (power surge), and 6 (RF immunity)
- Safety: EN60950

## Hardware Features For Specific NSM Models

This section lists all NSM models and the hardware specifications that are specific to each. For general hardware information, see “Hardware Features Common To All NSM Models” on page 5.

### AT-AR040 NSM

The AT-AR040 provides four Port Interface Card (PIC) slots (Figure 1 on page 6).

**Figure 1: AT-AR040 NSM with three PICs.**

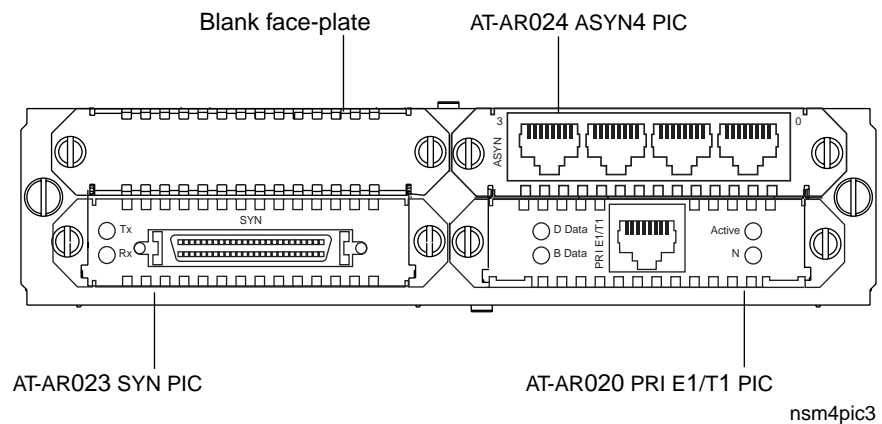

This NSM supports combinations of the following PICs (with a maximum of 2 E1/T1/PRI cards):

- AT-AR020 PRI E1/T1 (Primary Rate ISDN)<sup>1</sup>
- AT-AR021 (S) BRI-S/T (Basic Rate ISDN S/T)
- AT-AR021 (U) BRI-U (Basic Rate ISDN U)
- AT-AR022 ETH PIC (Ethernet 10BASE-T/AUI port)<sup>2</sup>
- AT-AR023 SYN (Synchronous RS-232/X21/V35 DCE/DTE to 2Mbps)
- AT-AR024 ASYN4 (Four Asynchronous ports)
- AT-AR026 4ETH PIC (Four 10BASE-T/100BASE-TX Ethernet ports)

1. Up to two PRI E1/T1 PIC cards (AT-AR020) can be installed in the NSM. A maximum of 32 TDM slots are allowed in each NSM row, and the maximum aggregate bandwidth for each row is 2.6 Mbps. If two PRI E1/T1 PICs are installed, the first must be in the lower row (bay 0 or 1), and the second must be in the upper row (bay 2 or 3). If an AT-AR020 PRI E1/T1 PIC is installed in one of the rows in the NSM and operating in E1 mode, then this row cannot also have an AT-AR021(S) BRI-S/T PIC or an AT-AR021(U) BRI-U PICU PIC installed.

2. The AT-AR022 ETH PIC is not recommended for use in the NSM PIC bays when the NSM is installed in an AR740 Router, as performance of these interfaces is likely to be reduced. The AT-AR022 ETH PIC is not designed for use in the NSM PIC bays when the NSM is installed in a Rapier or AR800 Series switch.

## Interface numbering for NSMs

Interface numbering for each interface type (e.g., BRI, PRI, SYN, ETH, PORT) begins at 0 on the base switch or router, and continues until all interfaces of that type on the base unit are numbered. For AR740 routers, the numbering then continues with the PIC interfaces installed directly in the router's PIC bays, starting at PIC bay 0. For switches and routers, the numbering then continues with the interfaces installed in the NSM, starting with NSM PIC bay 0, and ending with NSM PIC bay 3.

We therefore recommend installing PICs in the router's PIC bays and NSM's PIC bays in this sequential order, so that interface numbering is not changed when a new PIC is installed.

## AT-AR041 and AT-AR042 NSMs

The AT-AR041 NSM provides eight Basic Rate ISDN S/T WAN ports (Figure 2 on page 7), while the AT-AR042 NSM provides four Basic Rate ISDN S/T WAN ports (Figure 3 on page 8). In both cases the ports use RJ45 connectors and provide TE interfaces. There are two status LEDs per port (Table 2 on page 18).



*AT-AR041 and AT-AR042 NSMs support point-to-point links. Point-to-multi-point links are not supported.*

**Figure 2: AT-AR041 NSM.**

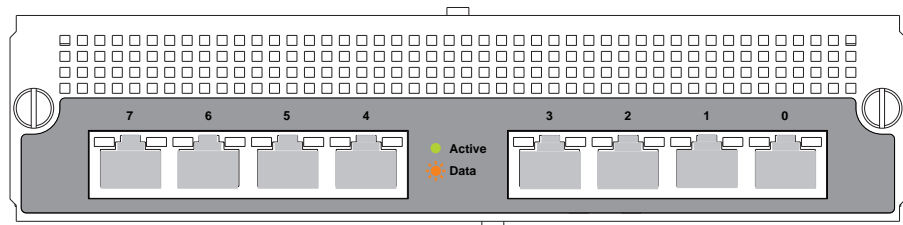
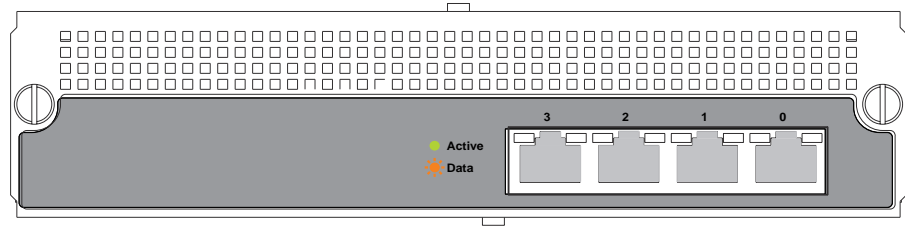

Figure 3: AT-AR042 NSM.



*More NSMs are planned, contact your Authorised Allied Telesyn distributor or reseller, or visit [www.alliedtelesyn.co.nz/support/support.html](http://www.alliedtelesyn.co.nz/support/support.html) to see if new models have been released.*

## Basic Rate ISDN Interfaces

The AT-AR041 and AT-AR042 NSMs provide Basic Rate ISDN (BRI S/T) interfaces, which support two 64kbit/s channels and one 16kbit/s D channel.

Both BRI NSMs support only TE mode. The switch or router should be configured as a TE for normal operation.

Board-mounted jumpers determine the interface termination. By default, the jumpers are set in the Terminated position (bridging terminals 2 and 3) when NSMs leave the factory (Figure 4 on page 9). To set the line pairs to Not Terminated, remove the jumper and replace it so that it bridges terminals 1 and 2. If the building wiring provides the correct termination for an ISDN TE-to-NT circuit, the jumper should be set in the Not Terminated position.

Figure 4: Location of jumpers on BRI NSMs.

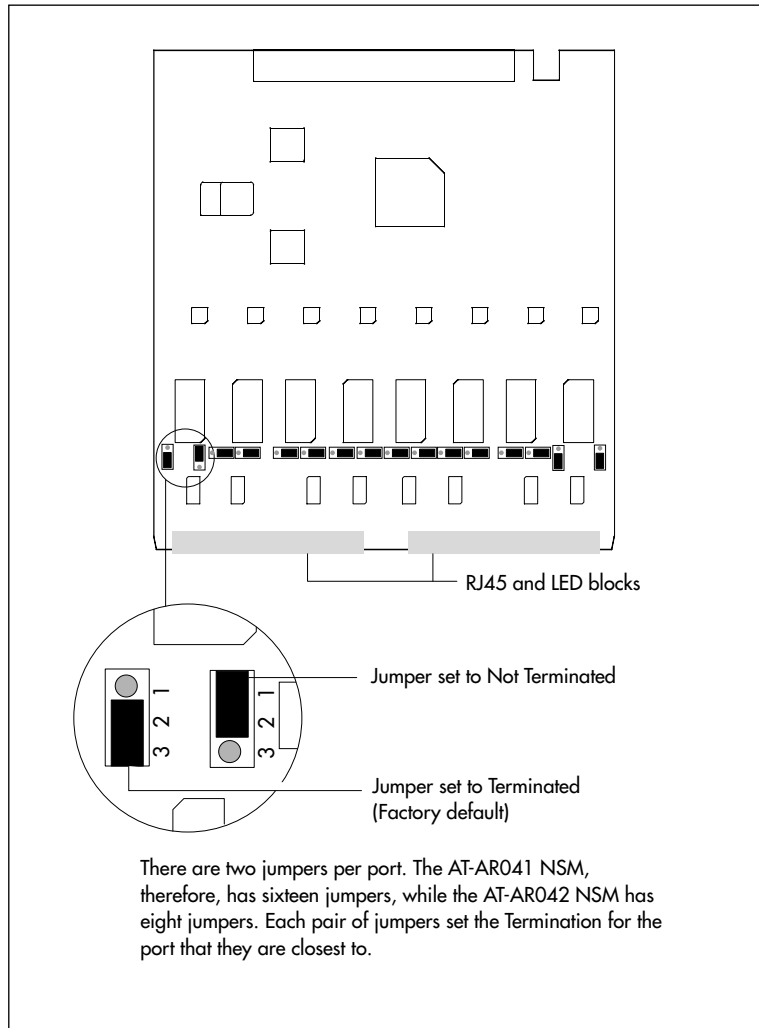

***If the building wiring provides the correct termination for an ISDN TE-to-NT circuit, the jumper should be set in the NotTerminated position***

The *Integrated Services Digital Network (ISDN)* chapter of the Software Reference or Reference Manual for your switch or router has additional information termination of ISDN lines.



*If you are unsure of whether to terminate the line or not, contact your ISDN service provider or your Authorized Allied Telesyn distributor or reseller.*

The pinout of the BRI interface is shown in Table 1 on page 10.

Table 1: Pinout of the Basic Rate ISDN S/T interface .

Pin	S/T Interface Functions
1	-
2	-
3	TX+
4	RX+
5	RX-
6	TX-
7	-
8	-

## ISDN S/T Interface Cables

Figure 5 on page 10 shows how to wire a cable to connect a Basic Rate Interface (BRI) to the ISDN network terminating equipment (NT).

Figure 5: Pin wiring diagram for an ISDN Basic Rate straight-through Interface cable.

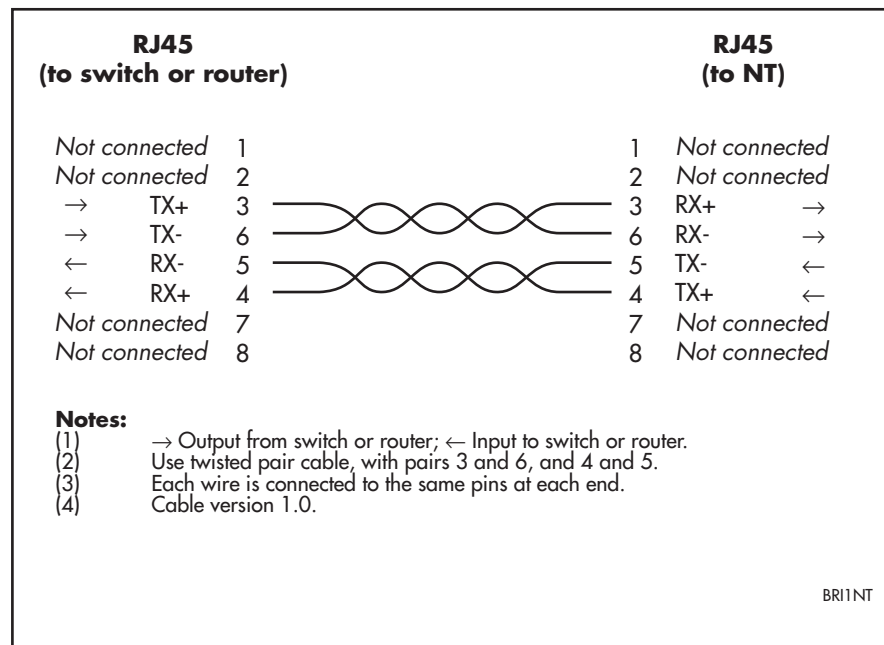

## Testing a BRI NSM

A Test Facility is built into all switch and router software. The Test Facility is designed to test physical interfaces. Testing can be performed while the switch or router is operational, but any interfaces being tested are dedicated to the Test Facility. The Test Facility can be thought of as a specialised interface module like PPP or Frame Relay.

When testing BRI interfaces, the Test Facility is used in conjunction with a BRI S/T loopback plug. A loopback plug must be inserted into each interface that you wish to test. Figure 6 on page 11 shows how to wire the loopback plug.

**Figure 6: BRI S/T loopback plug.**

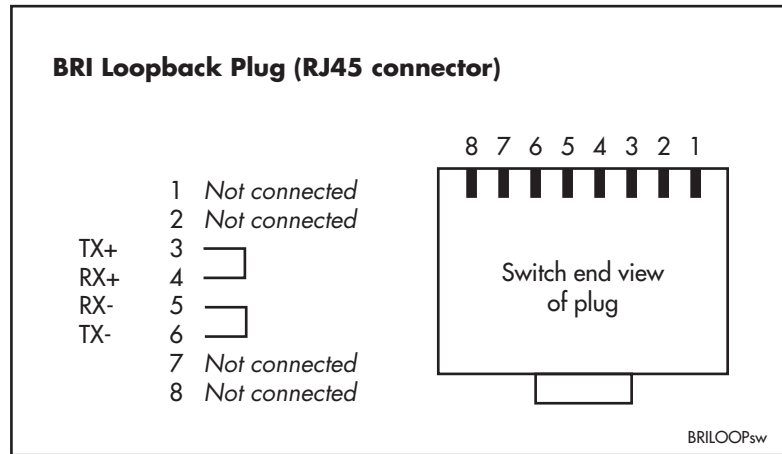

For more information on the Test Facility's operation, see the *Test Facility* chapter of the Software Reference or Reference Manual for your switch or router.

To test a specific AT-AR041 or AT-AR042 interface, insert a BRI S/T loopback plug into the interface and enter the command:

```
ENABLE TEST INTERFACE=BRIn
```

where *n* is the interface number.

To test all AT-AR041 or AT-AR042 interfaces at once, insert BRI S/T loopback plugs into all NSM BRI interfaces and enter the command:

```
ENABLE TEST INTERFACE=EXPANSION
```

In both cases the tests will run for 4 minutes.

Test results are displayed with the command:

```
SHOW TEST
```

which produces a display like that shown in Figure 7 on page 12.

The status of the tests for each interface will be shown in the right-most column of the output. For more information on the meanings of the other figures, see the *Test Facility* chapter of the Software Reference or Reference Manual for your switch or router.

If you are unsure about running the Test Facility, or have difficulty evaluating the results, contact your Authorised Allied Telesyn distributor or reseller.

Figure 7: Example output from the SHOW TEST command.

Board	ID	Bay	Board Name	Rev	Serial number
Base	78		AR740	M1-15	46625812
PIC	38	0	AT-AR023-00 PIC Sync	M1-1	5918255
NSM	95		AT-AR041-00 NSM 8BRI	P1-3	46624968
Interface	State	Result	Type	Duration (minutes)	Details Data( %OK )
Control					
eth0	complete	good	trans	0	- - -
			TP	1	good(100.0) -
			ENDEC	1	good(100.0) -
eth1	complete	good	MAC	1	good(100.0) -
			trans	0	- - -
			TP	2	good(100.0) -
			ENDEC	0	- - -
			MAC	2	good(100.0) -
syn0	complete	* BAD	RS-232dte	1	good(100.0) BAD
			dce	1	good(100.0) BAD
			X.21 dte	1	good(100.0) BAD
			dce	1	good(100.0) BAD
			V.35 dte	1	good(100.0) BAD
			dce	1	good(100.0) BAD
asyn0	complete	check this screen	-	4	- - -
asyn1	complete	good	-	4	good(100.0) good
BRI0	complete	good	-	4	good(100.0) -
BRI1	complete	good	-	4	good(100.0) -
BRI2	complete	good	-	4	good(100.0) -
BRI3	complete	good	-	4	good(100.0) -
BRI4	complete	good	-	4	good(100.0) -
BRI5	complete	good	-	4	good(100.0) -
BRI6	complete	good	-	4	good(100.0) -
BRI7	complete	good	-	4	good(100.0) -

For more complete testing, connect the BRI interface to an external ISDN test device and use the ENABLE BRI CTEST command and the DISABLE BRI CTEST command from the *Integrated Services Digital Network (ISDN)* chapter (of the Software Reference or Reference Manual for your switch or router). This test will execute conformance loopback tests and generate packets.



*If a test fails, please contact your Authorised Allied Telesyn distributor or reseller.*

For more information on using the Test Facility, see the Software Reference or Reference Manual for your switch or router.

## Hot Swapping

Hot Swapping is the installation or removal of a component (such as an NSM) without powering down or restarting the switch or router.

NSMs can be hot swapped in and out of switches and routers that are running Software Release 2.3.1 or later.

To find out which software release your switch or router is running, use the command:

```
SHOW RELEASE
```



---

*PICs can be swapped only if they are installed in an AR040 NSM. PICs installed in bays on base units (e.g., the chassis PIC bays on AR720 and AR740 routers) cannot be hot swapped.*

---

## Hot Swapping the AR040 NSM with PICs

When an AR040 NSM with PIC cards is hot swapped out, and an identical combination of AR040 and PICs is hot swapped into the same bay, the software configurations for the PIC interfaces are preserved across the hot swap. In this case, modules configured to the PIC interfaces transfer to the newly swapped in interfaces.

When an AR040 NSM with PICs is hot swapped out and a different combination of AR040 and PICs is hot swapped into the same bay, new interface instances are created for any new PIC types or PIC types that are in different bays (the old interface instances are discarded). For any PIC in the combination that is replaced by a PIC of the same type, interface instances are preserved.



---

*The recessed Hot Swap button must be used when hot swapping PICs. See the PIC Quick Install Guide or PIC Hardware Reference for the correct procedure for hot swapping PICs.*

---

## How to Hot Swap an NSM



---

*This procedure requires Software Release 2.3.1 or later.*

---



---

**WARNING:** *Failure to follow this procedure when hot swapping an NSM will cause the router to crash, and may damage files stored in FLASH.*

---



---

*The AT-AR040 NSM can be hot swapped with PICs installed in its PIC bays. There is no need to remove the PICs before hot swapping. See "Behaviour of Hot Swapped Interfaces" on page 15 for information on the operational characteristics of hot swapped interfaces.*

---

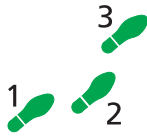

### To hot swap an NSM:

#### 1. Prepare the NSM bay for hot swap

If the In Use LED (next to the NSM bay) is lit, use a pencil tip or similar object to press the recessed Hot Swap button. The In Use LED should go out and the Swap LED should light.

If the In Use LED remains lit, or if neither the In Use or Swap LED are lit, the router software release does not support hot swapping, and the Standard Installation Method must be used to install or remove the NSM.



*Do not attempt to hot swap while the contents of FLASH are being modified; for instance, during FLASH compaction or when files are being loaded onto the router. If the router crashes while FLASH is being modified, configuration files, software release files, feature licences and other files may be damaged.*

#### 2. Prepare the NSM

In an antistatic environment, remove the NSM from its packing material. Be sure to observe ESD precautions.



*Do not attempt to install an NSM without observing correct antistatic procedures. Failure to do so may damage the switch, router, or NSM. If you are unsure what the 'correct' procedures are, contact your authorised Allied Telesyn distributor or reseller.*

#### 3. Remove the switch or router NSM-bay face-plate or existing NSM

If the switch or router does not have an NSM installed, remove the blank NSM-bay face-plate by loosening the two M4 Phillips screws.

If an NSM is already installed, disconnect its network cables and TNV lines before removing it from the switch or router.

Remove the NSM by unscrewing both thumbscrews at the same time. As the thumbscrews are turned, they will push the NSM out of the bay.



*When removing an NSM, take care to turn each thumbscrew by an equal amount to ensure that the NSM does not become misaligned. Forcing a jammed thumbscrew may damage the NSM card.*

If a thumbscrew becomes tight, it must not be forced. Instead, screw it in or out slightly to loosen it and then try again, taking care to unscrew both thumbscrews at the same rate.



*Keep the face-plate for future use. If you remove an NSM, replace the face-plate to prevent dust and debris from entering the switch or router and to maintain proper airflow.*

#### 4. Slide the NSM into place

Slide the NSM into the NSM bay, making sure that the ends of the thumbscrews are aligned with the screw holes on the switch or router.

#### 5. Secure the NSM

When the thumbscrews hit the threaded bushes, preventing the NSM from being pushed in further, turn the thumbscrews to engage their threads. Tighten both thumbscrews at the same rate to pull the NSM into position.

The screws will both tighten when the NSM panel is in its installed position, about .5mm proud of the switch or router rear panel. The thumbscrews should be firm, but not over-tight.

If one thumbscrew becomes tight before the other, loosen it slightly before proceeding.

#### 6. Installing PICs in the AT-AR040 NSM

If you have PICs to install, install them now by following the *Port Interface Card Quick Install Guide*. If there are more PIC bays than PICs, use the bays on the switch or router base unit first, then fill the NSM PIC bays, starting with bay 0.

#### 7. Return the NSM bay to use

Press the recessed Hot Swap button. The Swap LED will go out and the In Use LED will light.

If the In Use LED lights only briefly and the Swap LED then lights continuously, the NSM is of a type that the software release does not support.

#### 8. Verify the installation

Check that the switch or router has recognised the NSM. Use the SHOW SYSTEM command. If there is no NSM entry in the output, the switch or router has failed to recognise the NSM.

If the In Use LED fails to light or Recognition fails, repeat the installation process, paying particular attention to steps 4 and 5.

If the reinstallation fails, use the Standard Installation Method or see the "Troubleshooting" on page 17.

## Behaviour of Hot Swapped Interfaces

When an interface (PIC or NSM) is hot-swapped out, its interface instances become dormant. They stay dormant until either another interface of the same type is hot-swapped into the bay, in which case they are reactivated, or an interface of a different type is hot-swapped into the bay, in which case they are discarded.

Dormant interfaces are included in the SHOW INTERFACE command output and in the SNMP interfaces MIB, marked as swapped out. In other router or switch commands, however, the router or switch behaves as though dormant interfaces do not exist.

Instances of higher-level modules (such as LAPD and Q931, ISDNCC, PPP, and IP) do not become dormant when an interface becomes dormant. Instead they behave as if the interface has stopped communicating, for example, as if the cable has been unplugged.



---

*The configuration script is not scanned for commands relating to hot-inserted interfaces until the switch or router is restarted. These interfaces must be configured manually.*

---



*The switch or router does not update the MAC address of any hot-swapped Ethernet interface until the switch or router is restarted.*

The SHOW INTERFACE command is modified to show “Swapped out” in the ifOperStatus column for dormant interface instances.

All other commands that show or set interface properties behave as if swapped-out interfaces do not exist. Commands that operate on multiple interfaces skip swapped-out interfaces. Commands specified explicitly to a dormant interface display an error message.

**Figure 8: Example output from the SHOW INTERFACE command.**

```

Interfaces                               sysUpTime:           00:00:46

DynamicLinkTraps.....Disabled
TrapLimit.....20

Number of unencrypted PPP/FR links.....0

ifIndex Interface      ifAdminStatus ifOperStatus          ifLastChange
-----
 1      eth0             Up             Up                    00:00:03
 2      eth1             Up             Down                  00:00:00
 3      bri0             Up             Swapped out          00:00:43
 4      eth2             Up             Swapped out          00:00:42
-----

Interface name summary

Interface Full name
-----
asyn0    asyn0
asyn1    asyn1
eth0     eth0
eth1     eth1
-----

```

**Figure 9: Example output from the SHOW INTERFACE command for a specific interface.**

```

Interface..... bri0
ifIndex..... 3
ifMTU..... 1712
ifSpeed..... 144000
ifAdminStatus..... Up
ifOperStatus..... Swapped out
ifLinkUpDownTrapEnable... Disabled
TrapLimit..... 20

Interface Counters

ifInOctets ..... 52190          ifOutOctets ..... 52190
ifInUcastPkts ..... 3071        ifOutUcastPkts ..... 3071
ifInNUcastPkts ..... 0          ifOutNUcastPkts ..... 0
ifInDiscards ..... 0            ifOutDiscards ..... 0
ifInErrors ..... 0              ifOutErrors ..... 0

```

## Troubleshooting

---

This section provides information on how to detect and resolve problems with NSMs.

Other sources of troubleshooting information are:

- The Installation Guide or Reference Manual for your switch or router.
- [www.alliedtelesyn.co.nz/support/support.html](http://www.alliedtelesyn.co.nz/support/support.html)

### Performing the following tasks will eliminate the most common faults.

1. Check that the NSM is correctly installed. See the *Network Service Module Quick Install Guide* for a step by step guide to installing an NSM.
2. Make sure the power cord is securely connected to the switch or router and the power outlet.
3. Check that the power supply voltage to the switch or router is stable.
4. Check that the correct data cables are being used and that their connections are secure.
5. Make sure that other network devices are working properly.
6. Use the SHOW INSTALL command to check that the latest software release is loaded. The Reference Manual or Software Reference for your switch or router has more information about obtaining and installing the latest software release.
7. If the switch or router is malfunctioning, reboot it by pressing the recessed Reset button or entering the command RESTART REBOOT. Alternatively, power OFF and ON the switch or router by disconnecting and reconnecting the main power supply (including, if connected, the RPS power).

## Fault Indicators and What They Mean

This section provides information on LEDs for NSMs and related hardware.

### AT-AR040 NSM

The AT-AR040 NSM unit has no independent LEDs. See Table 3 on page 18 for information about related LEDs found on the base-unit switch or router.

## AT-AR041 and AR042 NSMs

The AT-AR041 and AT-AR042 have two LEDs per port. The LEDs are located on the NSM's face-plate.

**Table 2: AT-AR041 and AT-AR042 LEDs.**

LED	State	Function
Active	Green	Lit when the BRI has successfully completed the exchange of INFO 1 and INFO 2 signals, and INFO 3 and INFO 4 signals are present on the link. This means that the ISDN interface is correctly connected to a working NT device
	Off	There is no connection to the ISDN, or the ISDN has deactivated the connection
Data	Amber	For on-demand ISDN, lit when there is a call up over the respective B channel For permanent circuits, lit when HDLC packets are being exchanged between the switch or router and another TE end system device (normally another switch or router) over the respective B (data) channel
	Flashing Amber	For on-demand ISDN, flashing when data is being exchanged
	Off	For on-demand ISDN, Off when there is no active connection or when continuous data exchange is occurring For permanent ISDN circuits, Off when no data exchange is occurring

## Switch and router LEDs related to NSMs

Switches and routers with NSM bays have the LEDs outlined in Table 3 on page 18 built into their chassis.

**Table 3: Base-unit NSM LEDs.**

These LEDs are located on the rear panel of switches or routers that have NSM bays.

LED	State	Function
In use (Rear panel)	Green	An NSM is installed, is receiving power, and is operational. The NSM and its PICs are not ready for hot swap
	Off	No NSM is installed, or the NSM is not installed correctly (the switch or router has not recognised the NSM)

**Table 3: Base-unit NSM LEDs.**

These LEDs are located on the rear panel of switches or routers that have NSM bays.

LED	State	Function
Swap (Rear panel)	Green	The NSM and its PICs are ready to be hot swapped
	Off	The Hot Swap button must be pressed before the NSM or its PICs can be hot swapped, or the software release does not support hot swapping <sup>1</sup>

1. Hot swapping is supported by software release 2.3.1 or later.

### PIC LEDs

The following tables may be helpful when diagnosing possible AT-AR040 NSM operational faults. These LEDs are located on the face-plate of the respective PIC. PICs are expansion options and must be purchased separately.

**Table 4: PIC LEDs (AT-AR020 PRI E1/T1).**

LED	Function
D Data	[ISDN mode only] Lit when HDLC packets are being exchanged between the switch or router and the ISDN switch over the D (signalling) channel
B Data	Lit when HDLC packets are being exchanged between the switch or router and another end system device (normally another switch or router) over any of the B (data) channels
Active	Lit whenever operational (i.e., no RAI or AIS set) frames are being received on the respective interface (PRI 0 or PRI 1) from another source
NT	[ISDN mode only] Lit when the PRI1 is operating in NT mode. This LED should not be lit during normal operation

**Table 5: PIC LEDs (AT-AR021(S) BRI-S/T).**

LED	Function
B1, B2	For on-demand ISDN, lit when there is a call up over the respective B channel and flashing when data is being exchanged For permanent circuits, lit when HDLC packets are being exchanged between the switch or router and another TE end system device (normally another switch or router) over the respective B (data) channel
Active	Lit when the BRI has successfully completed the exchange of INFO 1 and INFO 2 signals, and INFO 3 and INFO 4 signals are present on the link. This means that the ISDN interface is correctly connected to a working NT device
D	Lit when HDLC packets are being exchanged between the switch or router and the ISDN switch over the D (signalling) channel

**Table 6: PIC LEDS (AT-AR021(U) BRI-U).**

LED	Function
B1, B2	Lit when HDLC packets are being exchanged between the switch or router and another TE end system device (normally another switch or router) over the respective B (data) channel  For ISDN, lit when there is a call up over the respective B channel and flashing when data is being exchanged
Active	Lit when the U interface is in the <i>Activated</i> state (i.e., it is in a fully operational at layer 1)
D	Lit when HDLC packets are being exchanged between the switch or router and the ISDN switch over the D (signalling) channel

**Table 7: PIC LEDS (AT-AR023 SYN).**

LED	Function
Tx	Lit when data is being transmitted over the synchronous interface
Rx	Lit when data is being received on the synchronous interface

**Table 10: AT-AR026 4ETH PIC LED functions (Two LEDs per port).**

LED	Function
Left	Lit when the port is operating at 100Mbps and full duplex.
Right	Lit when a link has been established. Flashing when data is being transmitted through the port.

The AT-AR024 ASYN4 PIC does not have LEDs.

# Contacting Us

---

## Allied Telesyn Offices and Locations

**UNITED KINGDOM**

Tel: (+44) 1235 442500  
Fax: (+44) 1235 442590

**SWEDEN**

Tel: 08 131414

**NORWAY**

Tel: 2211 1181

**DENMARK**

Tel: 3332 3006

**FRANCE**

Tel: (+33) 01 60 92 15 25  
Fax: (+33) 01 69 28 37 49

**BELGIUM**

Tel: (+32) 2 481 60 60  
Fax: (+32) 2 463 17 06

**GERMANY**

Tel: (+49) 30 435 90 00  
Fax: (+49) 30 435 706 50

**GERMANY - SOUTH**

Tel: (+49) 8161 99 060  
Fax: (+49) 8161 99 0622

**EAST EUROPE - AUSTRIA**

Tel: (+43) 1 8762441  
Fax: (+43) 1 8762572

**ITALY**

Tel: (+39) 02 416047  
Fax: (+39) 02 419282

**SPAIN**

Tel: (+34) 91 5591055  
Fax: (+34) 91 5592644

**U.S.A.**

Fax: (425) 489-9191  
<http://www.alliedtelesyn.com>

**CANADA**

Tel: (905) 709-7444  
Fax: (905) 709-7400

**LATIN AMERICA**

Tel: 1-425-481-3852  
Fax: 1-425-489-9191

**SINGAPORE**

Tel: (+65) 383-3832  
Fax: (+65) 383-3830

**AUSTRALIA**

Tel: (+61) 2-9438-5111  
Fax: (+61) 2-9438-496

**NEW ZEALAND**

Tel: (+64) 3 339 3000  
Fax: (+64) 3 339 3001  
<http://www.alliedtelesyn.co.nz>