

Hardware Reference for AT-8900, AT-9900 and AT-9900s Series Switches
Document Number C613-03092-00 REV C

© 2003-2005 Allied Telesyn Inc. All rights reserved. No part of this publication may be reproduced without prior written permission from Allied Telesyn Inc.

Allied Telesyn Inc. reserves the right to change specifications and other information in this document without prior written notice. The information provided herein is subject to change without notice. In no event shall Allied Telesyn Inc. be liable for any incidental, special, indirect, or consequential damages whatsoever, including but not limited to lost profits, arising out of or related to this manual or the information contained herein, even if Allied Telesyn Inc. has been advised of, known, or should have known, the possibility of such damages.

All company names, logos, and product designs that are trademarks or registered trademarks are the property of their respective owners.

Contents

Models Covered by this Document	3
Why You Should Read This Document	3
Hardware Overview	4
Dimensions	4
Mounting system	4
Asynchronous serial port	4
AT-8900 Series Switch	5
Environmental conditions	5
Regulatory standards	5
Switching core	5
Processing core	5
Optional IPv6 accelerator card	5
AT-8948 model	6
AT-9900 Series Switch	7
Environmental conditions	7
Regulatory standards	7
Switching core	7
Processing core	7
Network processor accelerator card	7
AT-9924T/4SP model	8
AT-9924T model	8
AT-9924SP model	8
AT-9900s Series Switch	9
Environmental conditions	9
Regulatory standards	9
Switching core	9
Processing core	9
AT-9924Ts model	9
Switch LEDs	10
SFP port LEDs	10
RJ-45 port LEDs	10
Ethernet port LEDs	11
System LEDs	11
Using Online Documentation	12
Using AT-TFTP Server	13
Using Windows Terminal and HyperTerminal	14
How the Switch Starts Up	17
AT-8900 and AT-9900 Switches	17
Process flow	17
Overrides	17
Regular output	18
Types of messages	18
AlliedWare messages	18
AT-9900s Switches	20
Process flow	20
Overrides	20
Regular output	21
Fallback output	21
Bootloader messages	22
AlliedWare messages	23
SFP Ports	26
Approved SFP transceivers	26
Types of SFP transceivers	26
To insert or remove an SFP transceiver	27

Management Ports	28
RS-232 Terminal Port (ASYNO)	28
Out-of-Band Ethernet Management Port	28
Cables	29
RS-232 Terminal and Modem Cables	29
RJ-45 to DB9 female terminal cable	29
RJ-45 to DB9 male modem cable	30
Cables for RJ-45 Ethernet LAN Interfaces	30
Pin assignments	30
1000BASE straight-through cable	31
1000BASE crossover cable	31
Cable Guidelines	31
Troubleshooting Cables	32
Cable test	32
Cable lengths	32
Power Supply Units (PSUs)	33
Hardware overview	33
Approved PSUs and FOM	34
LEDs on the PSU and FOM	34
IPv6 Accelerator Card	34
How the card works	34
Verifying installation	34
Displaying information about the card	36
Memory Options	36
CompactFlash Card	36
Approved CFlash cards	36
Inserting and removing a CFlash card	37
Displaying data about a CFlash card	37
Testing a CFlash card	37
Dual In-line Memory Module (DIMM)	38
AT-9924T and AT-9924SP switches	38
AT-9924T/4SP switch	38
AT-9924Ts switch	38
Verifying DIMM installation	38
Expansion Options	39
SFP ports	39
XFP ports	40
RJ-45 ports	40
Test Facility	40
Testing Ethernet LAN Ports	40
Diagnostics	41
Enabling diagnostics mode	41
Running a diagnostic program	42
Troubleshooting	43
What to check first	43
L/A LED on a port is off	43
Power LED is off	44
Fault LED is on	44
Additional resources	44
For More Information	45
Document sets	45
Contacting us	45

Models Covered by this Document

This Hardware Reference includes information on these models:

- AT-8948
- AT-9924T/4SP
- AT-9924T
- AT-9924SP
- AT-9924Ts
- AT-PWR01 (either AC or DC power supply unit)
- AT-PWR02 (AC power supply unit only)
- AT-FAN01 (fan-only module)

Why You Should Read This Document

Use this document to familiarise yourself with the AT-8900, AT-9900, and AT-9900s Series switches and hardware features, including power supply units (PSUs). This reference can also help you with installation and maintenance. However, refer to the Software Reference for information about software configuration and installation procedures.

Keep this document or the CD-ROM in a safe place; it will be helpful if you purchase expansion options for the switch.

Hardware Overview

This section provides details about the physical characteristics of the following:

- **AT-8900 Series Switch**
 - **AT-8948 model**
- **AT-9900 Series Switch**
 - **AT-9924T/4SP model**
 - **AT-9924T model**
 - **AT-9924SP model**
- **AT-9900s Series Switch**
 - **AT-9924Ts model**

The AT-8900, AT-9900, and AT-9900s Series switches have the following common traits:

- Dimensions**
 - Height: 44.5 mm, plus 5.1 mm if the rubber feet are used
 - Width: 440 mm, excluding rack-mounting brackets
 - Depth: 440 mm, excluding PSU handles
 - Weight: Not more than 8.5 kg, which includes one power supply unit (PSU) and one fan-only module (FOM)
- Mounting system**
 - 1U rack mounting; 19-inch rack-mount kit as standard
- Asynchronous serial port**
 - Up to 115 kbps
 - Universal Asynchronous Receiver Transmitter (UART)
 - Standard RJ-45 connector
 - Hardware-flow control

AT-8900 Series Switch

The AT-8948 switch is the sole model in the AT-8900 Series and meets the exceptionally high performance demands of high-end applications. It delivers wire-speed switching performance in a robust 1U rack mount platform.

- Environmental conditions**
 - Operating temperature range: 0°C to 50°C (32 to 122°F)
 - Storage temperature range: -25°C to 70°C (-13 to 158°F)
 - Relative humidity range for operation: 5 to 80% non-condensing
 - Relative humidity range for storage: 5 to 95% non-condensing
 - Operational altitude: 3,050 metres maximum (10,000 feet)

- Regulatory standards**
 - EMC: EN55022 class A, FCC class A, and VCCI class A
 - Immunity: EN55024, EN61000-3 levels 2 (Harmonics), and 3 (Flicker)—AC models only
 - Safety: UL60950-1, CAN/CSA-C22.2 No. 60950-1-03, EN60950, AS/NZS60950, and EN60825-1
 - Certification: UL, cUL, and TUV

- Switching core**
 - Application-Specific Integrated Circuit (ASIC) switch chip
 - Non-blocking Layer 2 and Layer 3 IP switching
 - 256K IPv4 address table
 - 4K multicast table
 - 4K logical Layer 3 interfaces
 - Shared 32 Mbyte DDR-SDRAM packet buffer

- Processing core**
 - 350MHz RISC Processor
 - 128MBytes of Synchronous DRAM, expandable to 256MBytes or 512MBytes with DIMM
 - 32MBytes of fixed flash
 - CompactFlash slot for hot-swappable expansion of flash memory up to 128MBytes
 - 512 kBytes of SRAM
 - 32/66 PCI bus for 32-bit/33MHz
 - Silicon ID chip storing serial number, board ID, and MAC address

- Optional IPv6 accelerator card**
 - Slot for network processor accelerator card that provides accelerated IPv6 unicast and multicast routing in hardware
 - 4 K multicast table
 - 1000 accelerator hardware filters
 - 128MBytes Synchronous DRAM giving 64K IPv6 routes

AT-8948 model Key features are:

- Autonegotiating multi-layer gigabit switch
- 48 10BASE-T/100Base-TX ports (RJ-45 connectors), auto MDI/MDI-X, full or half duplex
- 4-port 1000BASE-X SFP uplink sockets, full duplex
- Hot-swappable, load sharing PSUs
- Optional AT-ACC01 [network processor accelerator card](#)

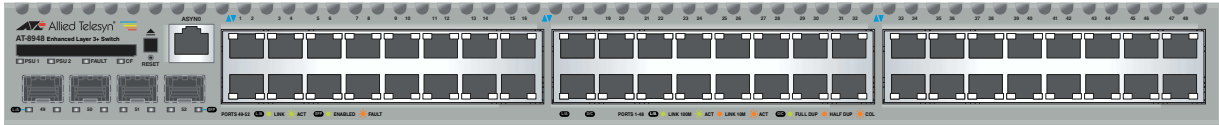
AT-8948 front panel

AT-9900 Series Switch

AT-9900 Series switches are advanced gigabit Ethernet multi-layer switches, perfect for the high-density rack environment where space is at a premium.

- | | |
|---|---|
| Environmental conditions | <ul style="list-style-type: none"> ■ Operating temperature range: 0°C to 50°C (32°F to 104°F) ■ Storage temperature range: -25°C to 70°C (-13°F to 158°F) ■ Relative humidity range for operation: 5% to 80% non-condensing ■ Relative humidity range for storage: 5% to 95% non-condensing ■ Operational altitude: 3,050 metres maximum (10,000 feet) |
| Regulatory standards | <ul style="list-style-type: none"> ■ EMC: EN55022 class A, FCC class A, and VCCI class A. ■ Immunity: EN55024, EN61000-3, levels 2 (Harmonics), and 3 (Flicker)—AC models only ■ Safety: UL60950-1, CAN/CSA-C22.2 No. 60950-1-03, EN60950-1, AS/NZS60950, and EN60825-1 ■ Certification: UL, cUL, and TUV |
| Switching core | <ul style="list-style-type: none"> ■ Application-Specific Integrated Circuit (ASIC) switch chip ■ High performance IPv4 switching <ul style="list-style-type: none"> AT-9924T and AT-9924SP <ul style="list-style-type: none"> • 64MByte packet buffer memory AT-9924T/4SP <ul style="list-style-type: none"> • High performance IPv6 switching • 160MByte packet buffer memory |
| Processing core | <ul style="list-style-type: none"> ■ 400MHz RISC Processor ■ 16MBytes of fixed flash with provision for an additional 16MBytes ■ CompactFlash card slot on the front panel for hot-swappable expansion of flash memory up to 128MBytes ■ 512kBytes of NVSRAM ■ Silicon ID chip storing serial number, board ID, MAC address, and hardware revision level <ul style="list-style-type: none"> AT-9924T and AT-9924SP <ul style="list-style-type: none"> • 128MBytes of Synchronous DRAM, expandable to 256MBytes or 512MBytes with DIMM AT-9924T/4SP <ul style="list-style-type: none"> • 256MBytes of Synchronous DRAM, expandable to 512MBytes with DIMM • 512MBytes of Synchronous DRAM is required if AT-ACC01 network processor accelerator card fitted |
| Network processor accelerator card | <ul style="list-style-type: none"> AT-9924T/4SP only <ul style="list-style-type: none"> ■ Optional network processor accelerator card provides accelerated IPv6 unicast and multicast routing in hardware ■ 512MBytes of Synchronous DRAM required, giving 64K IPv6 static routes ■ 4K multicast table ■ 1000 accelerator hardware filters |

AT-9924T/4SP model Key features are:

- Autonegotiating, multi-layer gigabit switch
- 24 10BASE-T/100BASE-TX/1000BASE-T ports (RJ-45 connectors)
- 4 Small Form Factor Pluggable (SFP) ports
- Hot-swappable, load sharing PSUs
- Optional AT-ACC01 network processor accelerator card

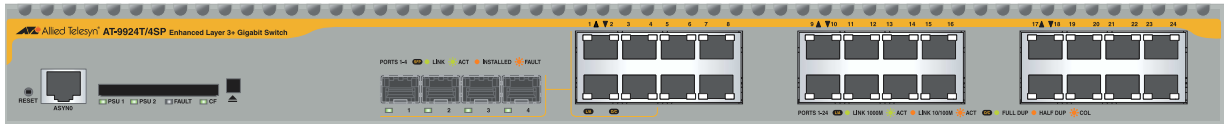
AT-9924T/4SP front panel

There are 24 ports operational at one time. The RJ-45 ports 1 to 4 use the same physical interface as the SFP ports 1 to 4. When an SFP is inserted into an SFP port, the corresponding RJ-45 port is disabled. For example, if an SFP is inserted in SFP port 1, then RJ-45 port 1 is disabled. When the SFP is removed from port 1, the RJ-45 port 1 is again operational. All other RJ-45 ports function normally.

AT-9924T model Key features are:

- Autonegotiating, multi-layer gigabit switch
- 24 10BASE-T/100BASE-TX/1000BASE-T ports (RJ-45 connectors)
- 4 Small Form Factor Pluggable (SFP) ports
- Hot-swappable, load sharing PSUs

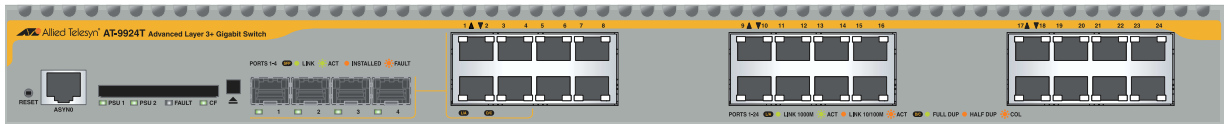
AT-9924T front panel

There can be 24 ports operational at one time. The RJ-45 ports 1 to 4 use the same physical interface as the SFP ports 1 to 4. When an SFP is inserted into an SFP port, the corresponding RJ-45 port is disabled. For example, if an SFP is inserted in SFP port 1 then RJ-45 port 1 is disabled. When the SFP is removed from port 1, the RJ-45 port 1 is again operational. All other RJ-45 ports function normally.

AT-9924SP model Key features are:

- Autonegotiating, multi-layer gigabit switch
- 24 Small Form Factor Pluggable (SFP) ports
- Hot-swappable, load sharing PSUs

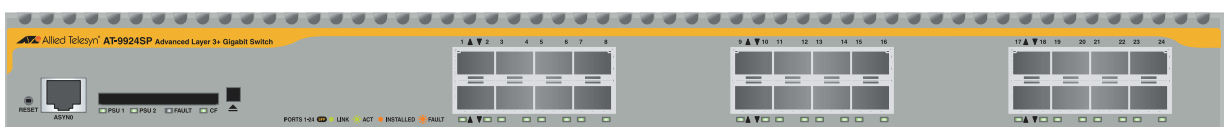
AT-9924SP front panel

AT-9900s Series Switch

The AT-9900s Series switch is a gigabit link aggregation switch that operates with other switches that have 10Mb/100Mb/1Gb/10Gb Ethernet ports. This switch can act as a gigabit server backbone or pass aggregated traffic over its gigabit ports. The switch can also aggregate gigabit desktop user connections and pass traffic to other 10 Gigabit Ethernet equipment.

- | | |
|---------------------------------|---|
| Environmental conditions | <ul style="list-style-type: none"> ■ Operating temperature range: 0° C to 40° C (32°F to 104°F) ■ Storage temperature range: -25° C to 70° C (-13°F to 158°F) ■ Relative humidity range for operation: 5% to 80% non-condensing ■ Relative humidity range for storage: 5% to 95% non-condensing ■ Operational altitude: 3,050 metres maximum (10,000 feet) |
| Regulatory standards | <ul style="list-style-type: none"> ■ EMC: EN55022 class A, FCC class A, and VCCI class A. ■ EN61000-3 levels 2 (Harmonics), and 3 (Flicker)—AC models only ■ Immunity: EN55024 ■ Safety: UL60950-1, CAN/CSA-C22.2 NO. 60950-1-03, EN60950-1, AS/NZS60950, and EN60825-1 ■ Certification: UL, cUL, and TUV |
| Switching core | <ul style="list-style-type: none"> ■ Application-Specific Integrated Circuit (ASIC) switch chip ■ High performance IPv4 switching ■ 128MByte packet buffer memory |
| Processing core | <ul style="list-style-type: none"> ■ 667MHz RISC Processor ■ 32MBytes of non-expandable fixed flash ■ 512MBytes Double Data Rate (DDR) Synchronous DRAM, expandable to 1 gigabyte ■ 512kBytes of NVSRAM |
| AT-9924Ts model | <p>The unmatched flexibility of the AT-9924Ts switch tailors solutions to a wide range of networking needs. It is currently the sole model in the AT-9900s Series. Key features are:</p> <ul style="list-style-type: none"> ■ Autonegotiating, multi-layer gigabit switch ■ 24 10/100/1000BASE-TX ports (RJ-45 connectors) ■ Out-of-band 10/100/1000BASE-T Ethernet management port ■ Two high-speed 20Gbps bays to support combinations of expansion modules ■ Supports dual, hot-swappable, load sharing PSUs (AT-PWR01)—a second PSU is optional ■ Optional 10GbE expansion module ■ Optional 12-port SFP expansion module ■ Optional 12-port RJ-45 expansion module |

AT-9924Ts front panel

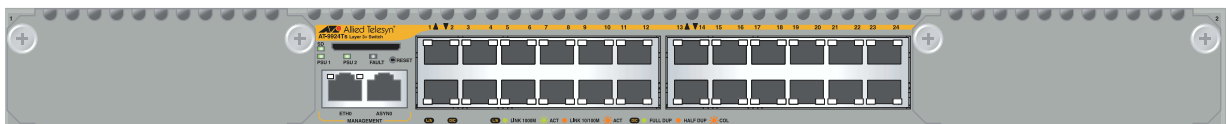

Switch LEDs

The following LEDs report operations and faults and on the AT-8900, AT-9900, and AT-9900s switches:

- [SFP port LEDs](#)
- [RJ-45 port LEDs](#)
- [Ethernet port LEDs](#)
- [System LEDs](#)

SFP port LEDs

LED	State	Description
L/A (Link Activity)	Green	On AT-8948 only, a 1000 Mbps link has been established and is operating in full duplex mode.
	Green flashing	On AT-8948 only, a full duplex activity is occurring at 1000 Mbps.
	Off	On AT-8948 only and when an SFP is installed, the link is closed.
SFP	Green	On the AT-9900 and AT-9900s switches, an SFP transceiver is installed and a link has been established. On AT-8948, an SFP transceiver is installed.
	Green flashing	On the AT-9900 and AT-9900s series, an SFP transceiver is installed and a link activity is occurring. Not valid for AT-8948.
	Amber	On the AT-9900 and AT-9900s switches, an SFP transceiver is installed but a link has not been established. Not valid for AT-8948.
	Amber flashing	An SFP transceiver is installed but there is a transmission fault.

RJ-45 port LEDs

LED	State	Description
L/A (Link Activity)	Green	A 1000 Mbps link has been established.
	Green flashing	1000 Mbps activity is occurring.
	Amber	A 10/100 Mbps link has been established.
	Amber flashing	10/100 Mbps activity is occurring.
D/C (Duplex/Collision)	Green	The port is operating in full duplex mode.
	Amber	The port is operating in half duplex mode.
	Amber flashing	Collisions are occurring.

Ethernet port LEDs

LED	State	Description
L/A (Link Activity)	Green	An XFP transceiver is installed and a 10 Gb link has been established.
	Green flashing	An XFP transceiver is installed and link activity is occurring.
	Amber	A 10/100 Mbps link has been established.
	Amber flashing	10/100 Mbps activity is occurring.
D/C (Duplex/Collision)	Green	The port is operating in full duplex mode.
	Amber	The port is operating in half duplex mode.
	Amber flashing	Collisions are occurring.

System LEDs

LED	State	Description
PSU 1	Green	PSU 1 is installed and supplying power to the switch. The voltage output is within specification. PSU 1 is in the right bay when facing the <i>rear</i> of the switch.
	Red	One of the following: <ul style="list-style-type: none"> PSU 1 is installed in the switch, and either a fan has failed or the PSU has exceeded its recommended temperature threshold of 75° C (167° F). A FOM is installed in the switch and a fan has failed. The bay is empty.
	Off	A FOM is installed and operating at an acceptable speed. For AT-9924T and AT-9924SP models, this LED is always off because a FOM is not required.
PSU 2	Green	PSU 2 is installed and supplying power to the switch. The voltage output is within specification. PSU 2 is in the left bay when facing the <i>rear</i> of the switch.
	Red	One of the following: <ul style="list-style-type: none"> PSU 2 is installed in the switch, and either a fan has failed or the PSU has exceeded its recommended temperature threshold of 75° C (167° F). A FOM is installed in the switch and a fan has failed. The bay is empty.
	Off	A FOM is installed and operating at an acceptable speed.

LED	State	Description (cont)
Fault	Red	The switch or management software is malfunctioning. This LED lights and then turns off after hardware initialises.
	1 Flash	One or more heatsink fans has failed or is operating below the recommended speed.
	6 Flashes	The switch's temperature has exceeded the recommended threshold. After flashing six times, the LED stops briefly, then repeats the sequence.
	3 Flashes	For AT-9900 and AT-9900s switches, the ability to monitor temperature and fans has failed, and it cannot report whether they are in the supported ranges. After flashing three times, the LED stops briefly, then repeats the sequence.
	Slow flashing at startup	The SDRAM (DIMM) has not been detected.
	Rapid flashing at startup	The SDRAM (DIMM) is not compatible with the switch.
CF	Green flashing	The CompactFlash memory card is active and should not be ejected. The card can be safely ejected when the LED remains off.
SD	Off	Secure Digital memory card. Not supported by 3.0.2 software.

Using Online Documentation

This section contains instructions on how to view online documentation on the CD-ROM. Adobe Acrobat Reader must be installed on your computer to view the documentation; you can install it from the CD.

1. Insert the Documentation and Tools CD in the CD-ROM drive.

If the browser menu does not appear, select Run from the Start menu. Then type `d:\start.exe` (where d: is the CD-ROM drive) in the text box, and click the OK button.

2. To view a specific document, click the document title.
3. To browse PDF documents, use any of the following to page through a document:
 - toolbar buttons, such as the Next Page button
 - keyboard shortcuts, such as arrow keys
 - commands from the Document menu
 - mouse wheel

To go to a specific section or topic, click a bookmark, thumbnail, or hypertext link.

Use the Search command to search for keywords or phrases.

For more information about using the Adobe Acrobat Reader, select Adobe Reader Help from the Help menu.

4. To install one of the tools from the CD, click the link on the browser screen.

Using AT-TFTP Server

This section explains how to access and use the AT-TFTP Server. You can transfer configuration files as well as download software upgrades with AT-TFTP Server.

1. If AT-TFTP Server has not been installed, install it from the Documentation and Tools CD-ROM.
Select AT-TFTP Server from the Start > Programs > Allied Telesyn > AT-TFTP Server menu.
2. To set preferences for the AT-TFTP Server, select Options from the File menu to display the Set Preferences dialog box shown below.

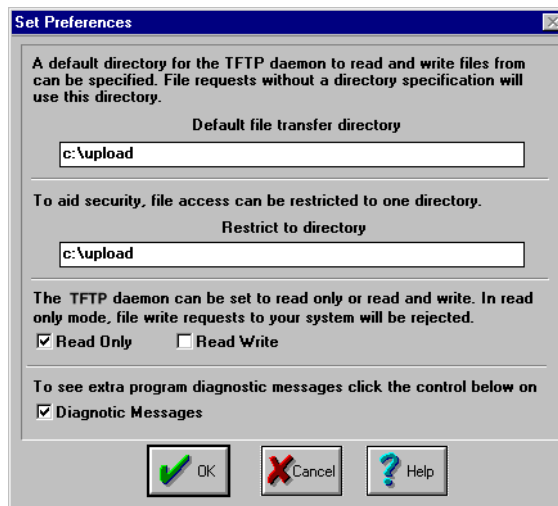

The "Default file transfer directory" field specifies the directory that AT-TFTP Server reads from or writes to for file requests that do not include a directory specification.

Enter a path name in the "Restrict to directory" field to prevent unauthorised access to private directories. AT-TFTP Server uses the specified directory even when file requests contain references to other directories.

To prevent files from being written to the PC, click the Read only checkbox.

To use the PC to archive scripts created using the switch's **create config** command, click the Read Write checkbox.

Click the OK button when you finish.

3. To load a file from AT-TFTP Server to the switch, type the following command on a terminal connected to the RS-232 Terminal Port (ASYN0):

```
load method=tftp file=filename server=ipadd dest=flash
```

where *filename* is the name of the file to download and *ipadd* is the IP address of the PC running AT-TFTP Server.

4. To save a TFTP Server log, select Save As from the File menu. TFTP requests are logged to the AT-TFTP Server main window.

Using Windows Terminal and HyperTerminal

You can use a PC running terminal emulation software as the manager console, instead of a terminal. There are many terminal emulation applications available for PCs, but the most readily available are the Terminal and HyperTerminal applications included in Microsoft Windows 98, 2000, and XP Professional. In standard Windows installations, HyperTerminal is available from the Communications submenu.

The key to successful use of terminal emulation software with the switch is to configure the software and switch with matching communications parameters. The following procedure can be applied to most terminal emulation programs. Dialog boxes in the procedure are from Windows 2000 and XP Professional.

To configure Windows HyperTerminal for 2000 and XP Professional

1. Start the program in Windows by doing one of the following:
 - Select Programs > Accessories > Communications > HyperTerminal.
 - Double-click the Hypertrm.exe icon.
2. In the Connection Description dialog box:
 - Enter a name for the connection, such as AT99001.
 - Select an icon from the scrollable list and click the OK button.

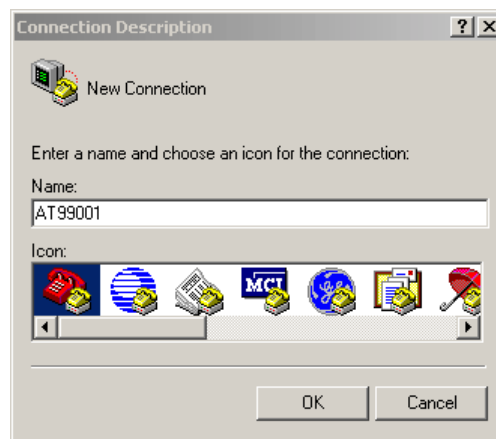

3. In the “Connect using” field on the Connect To dialog box, select the COM port on the PC used to connect to the switch. and click the OK button.

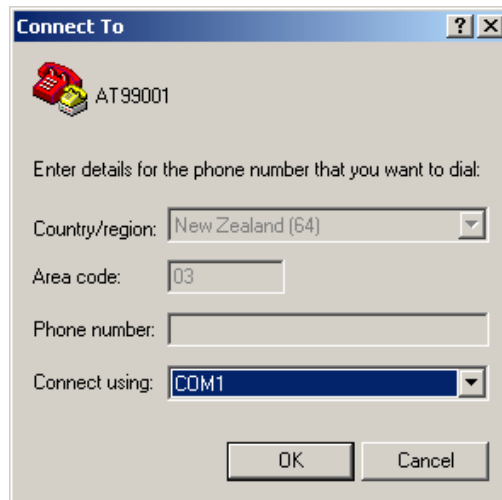

4. In the COM n Properties dialog box, set port parameters as follows, and click the OK button.

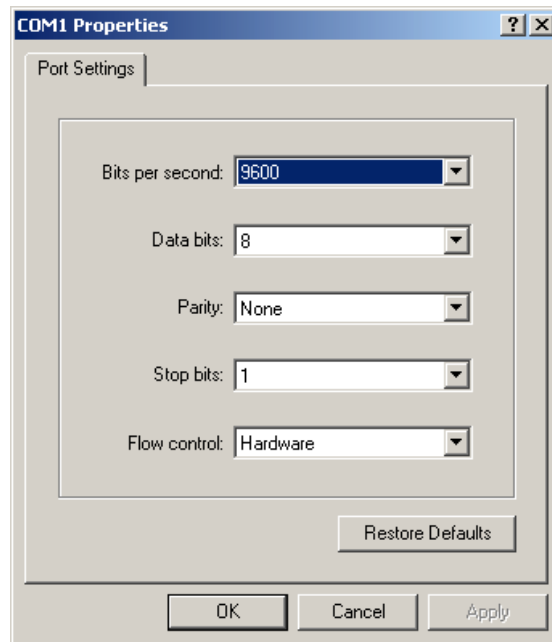

- From the main HyperTerminal window, select Properties from the File menu. Click the Settings tab, and set the Properties dialog box as follows.

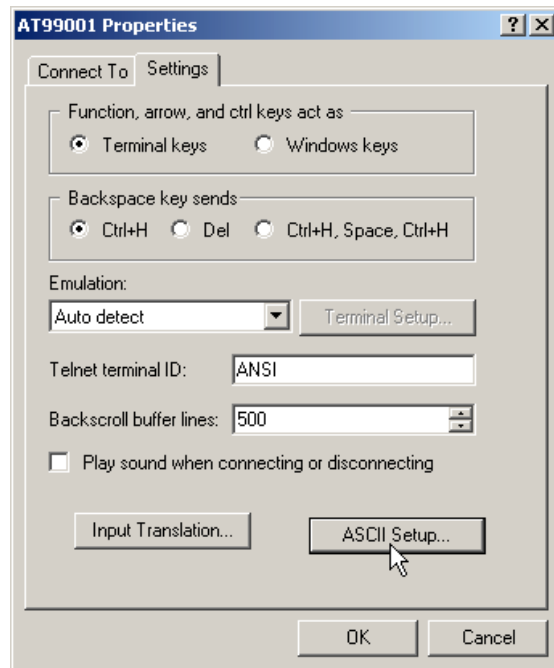

- Click ASCII Setup to display the ASCII Setup dialog box, and ensure the following options are **not** selected:
 - Echo typed characters locally
 - Append line feeds to incoming line ends

Set other parameters as necessary and click the OK buttons on both dialog boxes to close them.

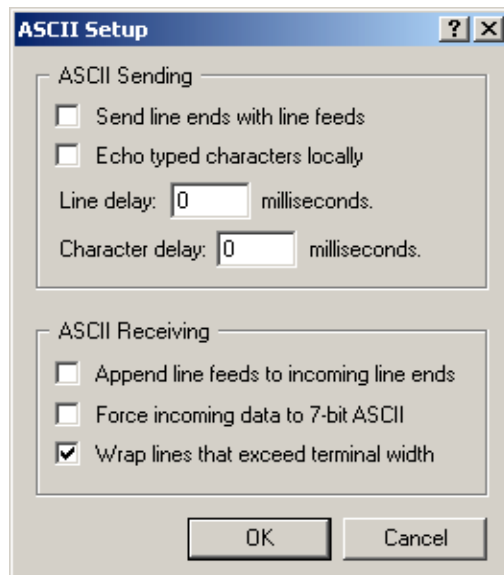

- Save the current session by selecting Save from the File menu on the main HyperTerminal window. This creates a connection icon with the name you assigned in the HyperTerminal group.

To use the configuration, double-click the connection icon. When the HyperTerminal window appears, press the Enter key several times; the switch's login prompt is then displayed.

How the Switch Starts Up

When the switch starts up following a power cycle or an operator-initiated reboot (using the reset button or **restart** command), it performs a series of tests and sends messages to the terminal or PC connected to the ASYN0 port. After the switch successfully starts, a prompt is displayed for you to log in. Refer to the Installation and Safety Guide for basic login instructions or to the *Getting Started* chapter in the Software Reference.

AT-8900 and AT-9900 Switches

Process flow When an AT-8900 or AT-9900 switch starts, it performs the following operations.

Stage	This happens...	Done by...
1	Self-tests run that check basic operations.	Boot ROM
2	A prompt is displayed briefly to allow a user-override. Users can change the startup process by pressing special keys (see Overrides). If they enter nothing, the process continues.	Boot ROM
3	The flash boot release is loaded as the install software.	Boot ROM
4	Install information is checked and the switch boots up from either the preferred or default install.	Boot ROM
5	The startup configuration script that the user specified is executed.	Preferred or default software
6	Startup is complete and the switch starts switching traffic if devices connected to it are sending traffic.	Release software

Overrides The switch pauses briefly during routine startup messages to display the following prompt:

```
Force EPROM download (Y)?
```

If you do nothing, switch software is loaded along with a preconfigured startup script. For troubleshooting, change the process by using the following keys.

Pressing this key...	Forces the switch to...
Y	Load the flash boot release with no patch.
S	Start with the default configuration so that any boot script is ignored.
Ctrl+D	Enter diagnostics mode. For more information, see "Diagnostics" on page 41 .

Regular output The following messages are an example of output from AT-8900 and AT-9900 switches.

```

INFO: Self tests beginning.
INFO: RAM test beginning.
PASS: RAM test, 131072k bytes found.
INFO: BBR tests beginning.
PASS: BBR test, 512k bytes found.
INFO: Self tests complete
INFO: Downloading switch software.

Force EPROM download (Y) ?

INFO: Initial download succeeded
INFO: Executing configuration script <boot.cfg>
INFO: Switch startup complete

```

Types of messages The following table explains the types of messages that AT-8900 and AT-9900 switches generate during initial startup.

Type	Description
INFO	An action has been taken by the system.
PASS	A test has been completed successfully.
ERROR	An error message that a test has failed but the system continues to operate.
FAIL	An error message that a fatal error condition has caused the system to halt in an unrecoverable fashion.

AlliedWare messages The following table explains messages in the output of AT-8900 and AT-9900 switches.

Message	Description
INFO: Self tests beginning.	Code loader tests are about to begin.
INFO: RAM tests beginning	RAM tests are about to begin.
PASS: RAM test, 131072k bytes found	RAM test passed and the switch is using the indicated amount of memory.
ERROR: RAM test <i>test-number</i> . Error address = <i>address</i> For example: ERROR: RAM test 5. Error address = 00345678	The given RAM test failed at the given address, which means the memory system is faulty. The test repeats until it passes. If the error continues, contact your authorised distributor or reseller.
INFO: BBR tests beginning	BBR battery tests are about to begin.
PASS: BBR test. Battery OK	BBR battery tests passed.
ERROR: BBR Battery low	BBR battery test failed, indicating that the battery is running low. The BBR battery must be replaced. Contact your authorised Allied Telesyn distributor or reseller.
PASS: BBR test, 512k bytes found	BBR size/location test passed with the indicated amount of BBR found.

Message	Description (cont)
FAIL: BBR test. Error address = <i>location</i>	BBR size/location test failed at the given location. The test at this location failed, indicating the end of memory, but a valid location was discovered in the 255 long words following this location. The BBR system must be replaced. Contact your authorised distributor or reseller.
FAIL: BBR test, only 16k bytes found	The BBR size/location test completed, but only the displayed amount of memory was found. This amount is less than the minimum required to run the switch software.
INFO: Self tests complete	Startup tests have finished.
INFO: Downloading switch software	The process of downloading the switch software and vector table from ROM is about to begin.
ERROR: Code load retried FAIL: Code load failed	Loading code from ROM to RAM failed. The load is retried a number of times, and the error message is displayed each time it fails. The fail message is displayed if the switch reaches the maximum number of attempts.
Force EPROM download (Y) ?	Prompt that lets you override the standard startup sequence, typically when troubleshooting.
INFO: Initial download succeeded	Startup tests and download are complete, and the switch software is about to be started. The release is now decompressed. This may take a few seconds.
INFO: Downloading compressed release. This may take up to 1 minute...	The main switch software is decompressed before being loaded into RAM.
INFO: Loading software into memory. This may take up to 1 minute...	
INFO: Executing configuration script <script-name>	Configuration commands in the given script file begin executing if selected by the user. If the script has an error, appropriate error messages are displayed.
INFO: Switch startup complete	The startup process is complete and the switch is ready. If devices connected to it are sending traffic, then the switch begins switching operations.

AT-9900s Switches

This section explains how AT-9900s switches start initially, including error messages. The following types of software play key roles during startup.

Software	Description
Base	Product software that is typically the “preferred” base package installed. It constitutes a feature set—similar to a “release”—and runs the switch. A software licence must be enabled for specific base packages.
Fallback	A small subset of the base package that runs when the base package is unavailable. It can download and install a base package, modify configuration scripts, and monitor the system.
Bootloader	Software that runs the switch when it first powers up. It performs basic initialisation, provides a basic interface for hardware diagnostics, and executes either the product or fallback software.

Process flow When the switch starts, it performs the following operations.

Stage	This happens...	Done by...
1	Self-tests run that check basic operations.	Bootloader
2	A prompt is displayed briefly to allow a user-override. Users can change the startup process by pressing special keys (see Overrides). If they enter nothing, the process continues.	Bootloader
3	Product software or fallback software is executed, depending on what the user installed.	Bootloader
4	Hardware boards and software components are initialised.	Base or Fallback
5	The startup configuration script that the user specified is executed.	Base or Fallback
6	Startup is complete and the switch starts switching traffic if devices connected to it are sending traffic.	Base

Overrides The AT-9900s switch pauses briefly during startup messages to display the following prompt:

```
Boot fallback software (Y)?
```

If you do nothing, the installed base package loads along with a preconfigured startup script. For troubleshooting, change the process by using the following keys.

Pressing this key...	Forces the switch to...
Y	Load the fallback software instead of the base package, and skip the startup configuration script.
S (skip)	Load the base package and skip the startup configuration script.
Ctrl+B	Display a bootloader prompt. To upgrade a bootloader file, load the new .bin file into the file system, and enter the command: <pre>copy filename.bin bootloader</pre> For information about the load command, see the <i>Managing Configuration Files and Software Versions</i> chapter in the Software Reference.
Ctrl+D	Enter diagnostics mode. For more information, see “Diagnostics” on page 41 .

Regular output Bootloader and product software (AlliedWare) display a series of messages similar to those in the following figure during routine startup for the AT-9900s switch.

```

-----
                          Bootloader v1-00, built Feb 10 2005
-----
Initial RAM test ..... passed
Available RAM ..... 512 MB
Relocating the bootloader to execute from RAM .... done

Boot fallback software (Y) ?

Initialising file system access ..... done
Booting preferred base package: AT9924s_301-00.pkg
Installing system.img (1219098 bytes) ..... done
Initiating system software ..... done

-----
                          AlliedWare v3.0.1-00, built 11 Feb 2005
-----
Initialising file system access ..... done
Validating package licence ..... done
Installing product_apps.img (8925892 bytes) ..... done

IGMP packet trapping has been activated for IGMP snooping
Executing configuration script <startup.cfg>
Switch startup complete

```

Fallback output Fallback software is a subset of the base package and runs when the base package is unavailable. When the switch runs fallback software, a series of messages similar to those in the following figure are displayed.

```

.
.                          (bootloader messages)
.
.
Installing system.img (1219098 bytes) ..... done
Initiating system software ..... done

-----
                          AlliedWare Fallback v3.0.1-00, built 11 Feb 2005
-----

WARNING: Fallback software will not allow normal
network operation

Initialising file system access ..... done
Installing product_apps.img (8925892 bytes) ..... done

Executing configuration script <startup.cfg>
Switch startup complete

```

Bootloader messages The following table explains messages that bootloader software displays at initial startup for the AT-9900s switch.

Message	Description
Bootloader <version>, built <date>	Banner that identifies the bootloader software.
Initial RAM test...passed or Initial RAM test...failed	Whether initial RAM tests are successful. If tests detect a problem with DRAM, the switch cannot be used. Contact your authorised distributor or reseller.
Available RAM...512 MB	The switch is using the amount of memory indicated.
Relocating the bootloader to execute from RAM...done or Relocating the bootloader to execute from RAM...failed	Whether bootloader software is successfully running from RAM instead of flash memory. If not successful, the system pauses indefinitely; contact your authorised distributor or reseller.
Boot fallback software (Y) ?	Prompt that lets you override the standard startup sequence, typically when troubleshooting . If you press Y, the switch boots from fallback software, and a confirmation message is displayed. For more information, see fallback output .
Initialising file system access...done or Initialising file system access...failed	Whether bootloader software has initialised access to the file system. Failure means a problem with the file system or memory device. The switch reformats memory and processing continues but data will be lost. Contact your authorised distributor or reseller.
Booting <i>install-type filename.pkg</i>	Name of the software package to be installed: preferred base package, temporary base package, or fallback. For information about types of install, see "Install Process" in the <i>Managing Configuration Files and Software Versions</i> chapter in the Software Reference.
Installing system.img <bytes>...done or Installing system.img <bytes>...failed	Whether the system software image of the given size is successfully installed in RAM and able to execute. This image is extracted from the installed package. If this fails when booting from a base package, the switch goes to the fallback software. If this file cannot be extracted from the fallback package, there may be a problem with fallback; contact your authorised distributor or reseller.
Initiating system software...done or Initiating system software...failed	Whether bootloader software has initiated execution of product software or fallback software, whichever the user selected, and is shifting control to it. If not successful, the system pauses indefinitely; contact your authorised distributor or reseller.

Bootloader Error Messages

Message	Description (cont)
ERROR: Fallback area is corrupt - launching the bootloader CLI	The switch is shifting to bootloader software because the fallback area in flash is unformatted or corrupt. It displays a bootloader prompt. Contact your authorised distributor or reseller before proceeding.
ERROR: No main board personality - launching the bootloader CLI	Unique information about the main PCB has not been programmed and the switch cannot start without it. Contact your authorised distributor or reseller.
No valid installed package - booting fallback software	The switch cannot find valid installed software, or files with install information are corrupt and the fallback area does not contain a valid file. The switch starts from fallback software. See the <i>Managing Configuration Files and Software Versions</i> chapter in the Software Reference for information about installation procedures, including the set install command.
ERROR: No valid software available - launching the bootloader CLI	The switch is shifting to bootloader software because it cannot find a valid package. It displays a bootloader prompt. Contact your authorised distributor or reseller before proceeding.
ERROR: Package <i>filename.pkg</i> is not valid	The switch could not extract the system image file because of a problem with the given package. Install a different package from fallback. Contact your authorised distributor or reseller if the problem continues.
ERROR: ELF header has <i>problem</i>	The system image file is corrupt or invalid due to the reason given. The switch tries to start from fallback software. If this fails, contact your authorised distributor or reseller.
ERROR: System image has no section headers	The system image file is corrupt or invalid because it has no section header information. Contact your authorised distributor or reseller.
ERROR: No memory available for storing <i>ELF element</i>	A serious problem exists with memory allocation software or memory on the switch. Contact your authorised distributor or reseller.

AlliedWare messages

The following table explains messages that the base and fallback software display at startup for the AT-9900s switch.

Message	Description
Alliedware <version>, built <date>	Banner that identifies the product software the switch is executing—base or fallback.
WARNING: Fallback software will not allow normal network operation	When starting from fallback software, a reminder that fallback is a subset of the product software and does not have its full functionality.
Initialising file system access...done or Initialising file system access...failed	Product software has initialised access to the file system. Failure means a problem with the file system or flash. Processing will continue but data will be lost. Contact your authorised distributor or reseller.
Validating package licence...done or Validating package licence...failed	Whether a valid licence has been found for the base package. Verify licence, version, and switch model and contact your authorised distributor or reseller if necessary. Not displayed for fallback.

Message	Description (cont)
Installing product_apps.img (8925892 bytes)...done or Installing product_apps.img (8925892 bytes)...failed	Whether the product application image of the given size is installed in RAM and able to execute. This file is part of the installed package. Failure could mean not enough RAM or the package is corrupt. Contact your authorised distributor or reseller.
IGMP packet trapping has been activated for IGMP snooping	IGMP packet trapping is enabled to allow IGMP snooping to function. A warning is displayed if this function could not be activated. Not displayed for fallback.
Executing configuration script <startup.cfg>	Configuration commands in the given script file begin executing if selected by the user. If the script has an error, appropriate error messages are displayed.
Switch startup complete	The startup process is complete and the switch is ready. If devices connected to it are sending traffic, then the switch begins switching operations.
AlliedWare Error Messages	
ERROR: Phase 1 of Software Manager startup failed - rebooting	Software Manager is part of the system software that controls startup of the product software. It failed to complete the first phase of its initialisation and cannot boot the fallback software. Manually restart the switch with fallback software (for details, see “Overrides” on page 20). If this error occurs while rebooting from fallback, contact your authorised distributor or reseller.
WARNING: Bad board of type <number> in Expansion Bay <number>	Board personality of the given type in the given bay could not be read. Possible causes include: <ul style="list-style-type: none"> unprogrammed personality PROM on the board faulty hardware on expansion or host board For information about boards, see the show system boards command in the <i>Configuring and Monitoring the System</i> chapter in the Software Reference.
WARNING: Unsupported board of type <number> in Expansion Bay <number>	Software does not support the board of the given type in the given bay.
Unit was rebooted because of a system exception	The switch is restarting after a system exception. Depending on the exception, you may need to contact your authorised distributor or reseller.
Creating core file system_release-number.core...done or Creating core file system_release-number.core...failed	Displayed after the switch restarts itself, and indicates whether system core information has been written to the specified file. Each image file creates its own core file and coredump. This information is loaded into RAM after a system exception and before the switch restarts. Contact your authorised distributor or reseller.
ERROR: Unable to read fallback package information	Information about fallback software is not available. Contact your authorised distributor or reseller.
ERROR: Unable to read preferred or temporary install information	Information is not available about the type of install indicated. The switch tries to start from fallback software. If this fails, contact your authorised distributor or reseller.

Message	Description (cont)
ERROR: Failed to extract product_apps.img from package to RAM	<p>The product application image could not be extracted from the package file because the package file is corrupt or there is not enough RAM.</p> <p>Manually restart the switch with fallback software (for details, see “Overrides” on page 20), and install another base package.</p> <p>If this error occurs while rebooting from fallback, contact your authorised distributor or reseller.</p>
ERROR: Failed to run product_apps.img	<p>The operating system could not execute the product application image file.</p> <p>Manually restart the switch with fallback software (for details, see “Overrides” on page 20), and install another base package.</p> <p>If this error occurs while rebooting from fallback, contact your authorised distributor or reseller.</p>
ERROR: Phase 2 of Software Manager startup failed - rebooting to fallback software	<p>Software Manager is part of the system software that controls startup of the product software. The install information for it is invalid or the installed software is not licenced. Therefore, the switch boots up from the fallback software.</p>

SFP Ports

SFP transceivers are compact, hot-swappable, and high speed. Certain fibre and copper SFP transceivers are supported so that you can interchange port types to meet changing network requirements. AT-8900 and AT-9900 switches have 1000BASE-X Small Form Factor Pluggable (SFP) uplink sockets conveniently located on the front panels.

- AT-8948, AT-9924T/4SP, and AT-9924T models have 4 SFP sockets
- AT-9924SP models have 24 SFP sockets

Approved SFP transceivers

You can purchase SFP transceivers when you purchase a switch or order them separately as needed. For details about tested and approved SFPs, see [“SFP ports” on page 39](#). Also see individual datasheets on the documentation CD for details.

For the latest list of approved SFP transceivers, contact your authorised distributor or reseller.

Types of SFP transceivers

Speed and duplex settings differ depending on the type of SFP transceiver installed in it.

- For an SFP port with an approved **fibre** SFP transceiver, the speed and duplex settings are fixed at 1000Mbps full duplex autonegotiation.
- For an SFP port with an approved **copper** SFP transceiver, the available speed and duplex settings are:
 - 10Mbps and 100Mbps half duplex
 - 10Mbps and 100Mbps half duplex autonegotiation
 - 10Mbps and 100Mbps full duplex
 - 10Mbps and 100Mbps full duplex autonegotiation
 - 1000Mbps full duplex autonegotiation

An error message is displayed when an SFP port cannot operate at the specified speed or duplex mode.

When using SFP ports 1 to 4 on AT-9924T/4SP and AT-9924T switches, the corresponding RJ-45 ports (1 to 4) are disabled. However, when the SFP transceiver is removed, the RJ-45 port becomes operational again.

To insert or remove an SFP transceiver

The SFP transceiver must be inserted the correct way in the socket, which varies depending on whether the switch has a single or dual row of sockets. For example, the AT-8948 has single-row sockets but the AT-9900 has a dual row. See the example of dual-row sockets for a copper SFP transceiver in the figure below. Notice the varying position of the release lever.



Warning Do not look into SFP cables or transceivers. Invisible laser radiation may be emitted from disconnected fibres or connectors.

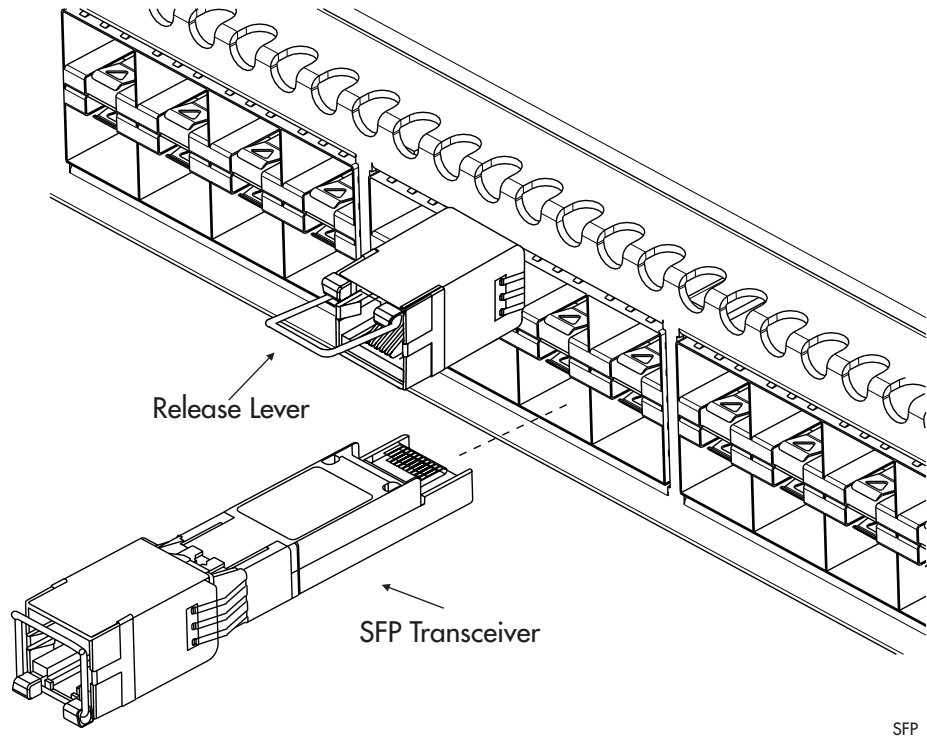

SFP

Slide the transceiver into the SFP socket, and firmly press it until it engages. To remove it, first release it by gently pulling the release lever, and then pull the transceiver out of the socket. **Never** force a transceiver into or out of a socket.

Management Ports

The following management ports let you configure, monitor, and upgrade the switch:

- **RS-232 Terminal Port (ASYN0)**
- **Out-of-Band Ethernet Management Port** (AT-9900s switch only)

RS-232 Terminal Port (ASYN0)

The RS-232 ASYN0 port is standard for the AT-8900, AT-9900, and AT-9900s switches, and connects them to a management device for initial configuration. This port allows the software on the switch to be accessed from a terminal or a PC running terminal emulation software.

The ASYN0 port has an RJ-45 socket with an industry recognised pinout. This requires using a straight-through RJ-45 cable with an RJ-45 DB9 connector when the switch is connected to a terminal or PC. The socket is wired as a DTE and the pin layout is shown in the following figure and table.

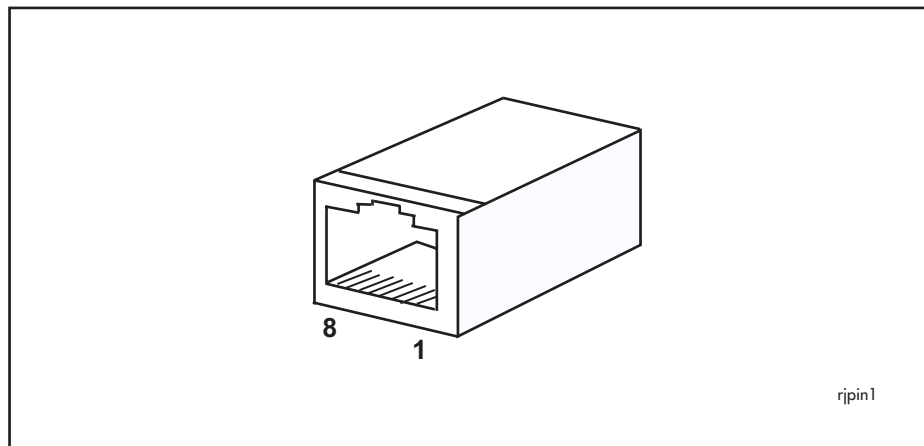

Pin	Role
1	RTS
2	DTR (DSR and DTR are connected but have no other internal connection)
3	TXD
4	GND
5	GND
6	RXD
7	DSR (DTR and DSR are connected but have no other internal connection)
8	CTS

Out-of-Band Ethernet Management Port

The out-of-band 10/100/1000 Mbps Ethernet port is dedicated to management traffic on the AT-9900s switch. Use it for initial configuration and on-going management tasks. For remote access, use the default IP address, 192.168.242.242. This port is reserved for management **only**; the switch does not transmit frames between this port and switch ports.

Cables

This section describes the following:

- [RS-232 Terminal and Modem Cables](#)
- [Cables for RJ-45 Ethernet LAN Interfaces](#)
- [Cable Guidelines](#)
- [Troubleshooting Cables](#)

RS-232 Terminal and Modem Cables

The terminal and modem cables described in this section are:

- RS-232 RJ-45 to DB9 female terminal cable
- DCE RS-232 terminal port RJ-45 to DB9 male modem cable

The following figures show pin wiring diagrams to connect a standard VT100 compatible terminal or modem to ASYN0.

RJ-45 to DB9 female terminal cable

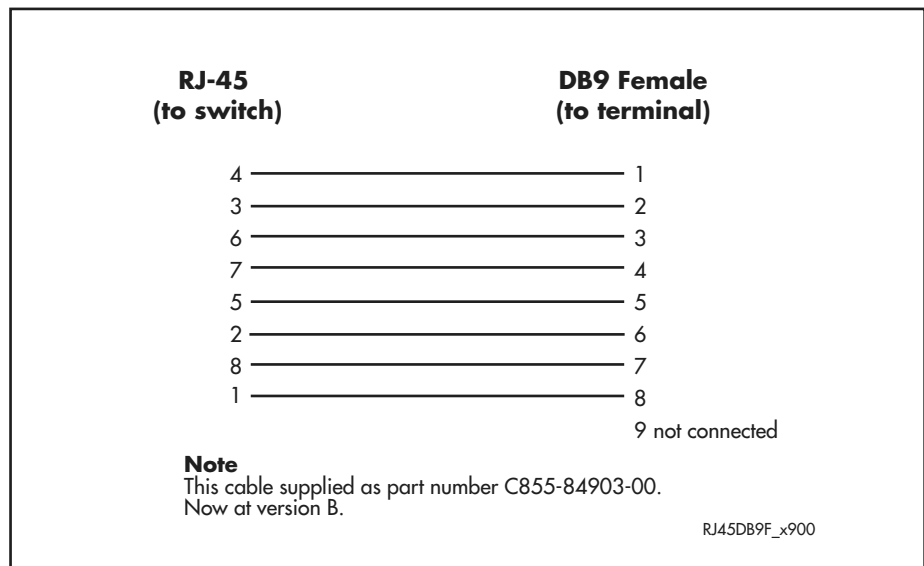

RJ-45 to DB9 male modem cable

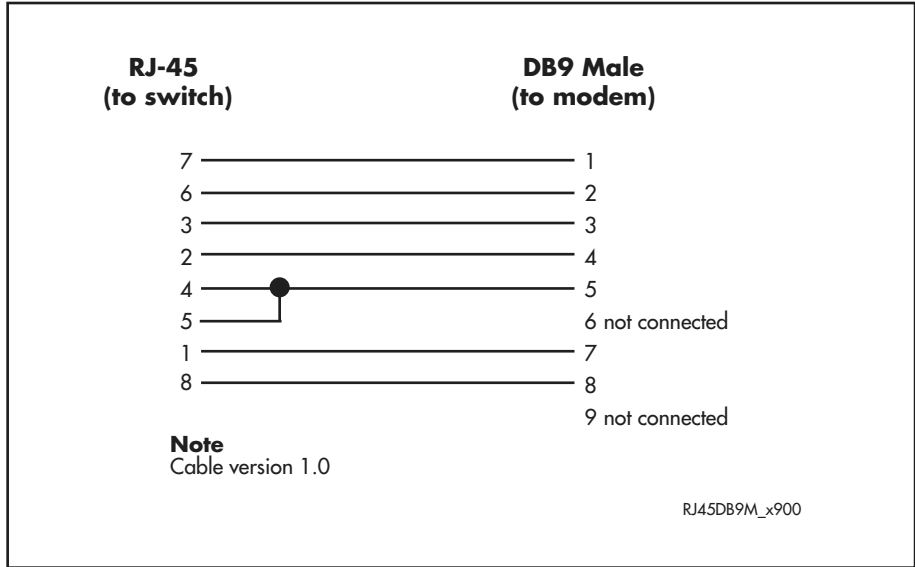

For more information on pin assignments for the RS-232 port, see “[RS-232 Terminal Port \(ASYN0\)](#)” on page 28.

Cables for RJ-45 Ethernet LAN Interfaces

A twisted pair cable with four pairs and RJ-45 connectors must be used for 10BASE-T/100BASE-TX/1000BASE-T connections.



Caution Do not plug a phone jack into an RJ-45 switch port because you could damage the switch. Use only twisted pair cables with RJ-45 connectors.

Pin assignments

Each pair of twisted pair cables is identified by related colors. For example, one wire might be red and the related wire would be red-and-white stripe. An RJ-45 connector must be fitted to both ends of the cable. The following diagram shows RJ-45 connectors and the pin layout.

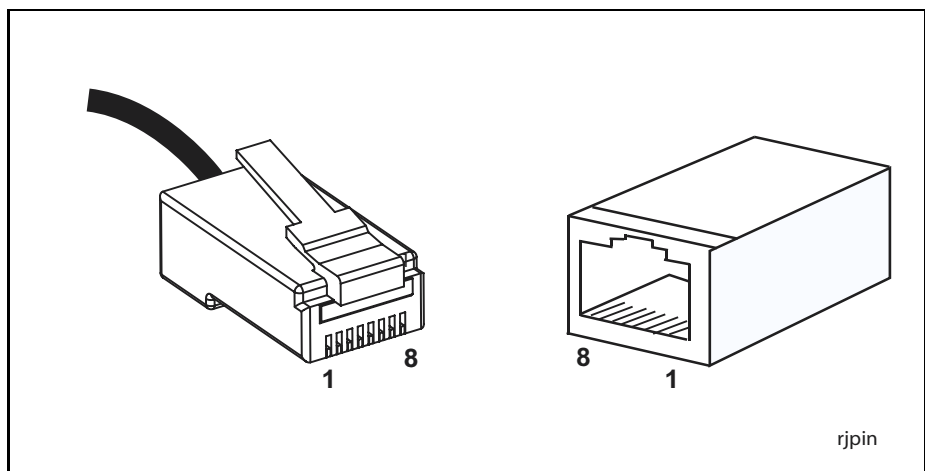

1000BASE straight-through cable

For 1000BASE network connections, all four pairs are used and the cable is wired in a straight-through configuration. You can use this cable with the software test facility to test 1000BASE network ports. The following table lists pin assignments for a 10/100/1000BASE-T RJ-45 four pair straight-through cable.

End 1		End 2	
Pin	Pair	Pin	Pair
1	Pair 1+	1	Pair 1+
2	Pair 1-	2	Pair 1-
3	Pair 2+	3	Pair 2+
6	Pair 2-	6	Pair 2-
4	Pair 3+	4	Pair 3+
5	Pair 3-	5	Pair 3-
7	Pair 4+	7	Pair 4+
8	Pair 4-	8	Pair 4-

1000BASE crossover cable

For 1000BASE test cables, all four pairs are used and the cable is wired in either a crossover or straight-through configuration. The following table lists pin assignments for a 10/100/1000BASE-T RJ-45 four pair crossover cable.

End 1		End 2	
Pin	Pair	Pin	Pair
1	Pair 1+	1	Pair 2+
2	Pair 1-	2	Pair 2-
3	Pair 2+	3	Pair 1+
6	Pair 2-	6	Pair 1-
4	Pair 3+	4	Pair 4+
5	Pair 3-	5	Pair 4-
7	Pair 4+	7	Pair 3+
8	Pair 4-	8	Pair 3-

Cable Guidelines

The following table lists port, connector, and cable combinations for switch models and expansion modules.

Model	Port Type	Connector Type	Cable Type ^I	Maximum Cable Length
AT-8948	10BASE-T	RJ-45	CAT5	100m Max
	100BASE-TX		CAT5E	120m Max
AT-9924T/4SP	10BASE-T			
AT-9924T	100BASE-TX			
AT-9924Ts	1000BASE-T			
AT-A62				
AT-8948	1000BASE-X	Varies with SFP	Refer to documentation packaged with SFP	Refer to documentation packaged with SFP
AT-9924T/4SP				
AT-9924T				
AT-9924SP				
AT-A61				

I. Refer to the IEEE Standard 802.3 for additional cable information

Troubleshooting Cables

Cable test The virtual cable test facility diagnoses cable faults and the approximate distance to them on Gigabit Ethernet RJ-45 ports for the following switches:

- AT-9924T
- AT-9924T/4SP
- AT-9924Ts

See [“Test Facility” on page 40](#) for more information or the *Test Facility* chapter in the Software Reference. Not all copper SFPs support this feature; however, those listed in [“Approved SFP transceivers” on page 26](#) do support it.

Cable lengths Approximate cable lengths are reported for gigabit Ethernet RJ-45 ports on the following switches:

- AT-9924T
- AT-9924T/4SP
- AT-9924Ts

Cable length is reported after the link is established. To check the length, use the **show switch port** command described in the *Switching* chapter in the Software Reference. The Cable Length parameter in the output of this command can be one of the following values:

- <50m
- 50-80m
- 80-110m
- 110-140m
- >140m
- - (either the port link is down, or the port is operating at 10Mbps or 100Mbps)

Power Supply Units (PSUs)

Two power supply bays are at the rear of the AT-8900, AT-9900, and AT-9900s chassis. Each switch is supplied with a single power supply unit (PSU), either AC or DC. Depending on the model, the switch has either a fan-only module (FOM) or a blanking panel:

- The AT-8948, AT-9924T/4SP, and AT-9924Ts switches have a PSU and a FOM installed.
- The AT-9924T and AT-9924SP switches have a PSU and a blanking panel installed. When there is just one PSU, it must be in Bay 2 for optimised cooling.

The following figure shows the rear view of the AT-8948, AT-9924T/4SP, and AT-9924Ts models.

PSU and FOM installed

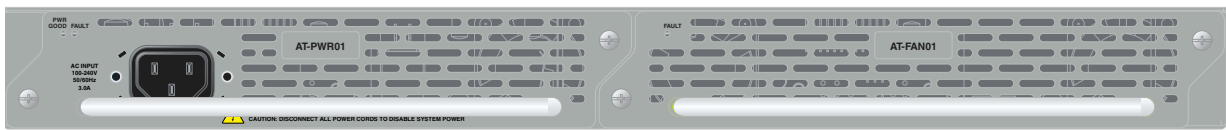

A second PSU is available as an option and provides redundancy. When two are fitted, they must be the same type of current, either AC or DC.

Each PSU and FOM contains an EPROM chip that contains information, such as the type of module, serial number, and revision of the PSU. This information is available through the command line interface (CLI).

How to install a PSU or FOM in the switch is described in the *Removable Power Supply and Fan Installation Guide*.

Hardware overview

- Power supply units (PSUs) are hot-swappable and load share
- Dimensions
 - Height: 40.9 mm
 - Width: 193mm
 - Depth: 130 mm
- AC models
 - Universal 100/240 VAC 47/63Hz input
 - Maximum continuous current draw: 2.2 A at 100V, 1.1 A at 230V
 - Maximum inrush current (cold start at 25°C/77°F): 70 A at 240V, 32 A at 115V

Caution Double pole/neutral fusing. The fuse rating for FH101 and FH102 is 250V, 5 A (AT-PWR01).
- DC models
 - 40 to 60V, 48V nominal
 - Supports either positive grounded or negative grounded operation
 - Maximum continuous current draw: 3.9 A at 40V
 - Maximum standby current: 100mA
 - Run/Standby switch

Approved PSUs and FOM

Product numbers for the power supply unit (PSU) and the fan-only module (FOM) that can be fitted in the AT-8900 and AT-9900 switches are:

- AT-PWR01(either AC or DC power supply unit)
- AT-PWR02 (AC power supply unit only)
- AT-FAN01 (fan-only module)

For the AT-9900s Series switch only, you can install the AT-PWR01 and AT-FAN01 models.

LEDs on the PSU and FOM

The following table describes how LEDs on power supply units and fan-only modules report faults and operational activities.

LED	State	Description
Fault	Red	There is either a fan failure, or the temperature has exceeded the limit of 75°C (167°F).
PWR	Green	A PSU is installed in the switch and is receiving power. The FOM does not have this LED.

IPv6 Accelerator Card

An optional AT-ACC01 network processor accelerator card accelerates IPv6 unicast and multicast routing in hardware on AT-8900 and AT-9924T/4SP switches. For full functionality, 512MB SDRAM must be installed in the switch.

How the card works

When the switch receives an IPv6 packet to route, the packet is sent to the network processor accelerator card. The card processes the packet and sends it out the correct port with appropriate alterations to the packet. Other IPv6 functions are passed to software, such as routing protocol control packets, encryption, authentication, and Hop-by-Hop headers.

No configuration is necessary for the accelerator card to function; the card is enabled at installation. If you disable the card (using software), the switch handles IPv6 routing in the software.

Use the hardware filter and QoS commands to enable Quality of Service (QoS) functionality on the accelerator card. For information about QoS functionality and hardware filters, see the *Quality of Service* and *Switching* chapters in the Software Reference.



Warning Only authorised service personnel should install a network processor accelerator card. Opening the switch's lid may cause personal injury from electric shock, could damage the switch, and will invalidate the product warranty.

Verifying installation

To confirm that the network processor accelerator card is installed and operating correctly, check that the switch has recognised it. Turn on the switch and enter the **show system** command to display system information. The

following figure is an example of output from the **show system** command for the AT-9924T/4SP switch.

```

Switch System Status          Time 14:50:14 Date 11-Nov-2004
Board      ID Bay  Board Name      Host Id Rev  Serial number
-----
Base       220    AT-9924T/4SP      0 M1-0      61556164
Acce1     210    AT-ACC01          0 M1-1      61493315
PSU       214    1 AT-FAN01          0 M2-1      61106469
PSU       212    2 AT-PWR01-AC      0 M2-1      60703190
-----
Memory -   DRAM :524288 kB   FLASH 16384 kB
-----
SysDescription
Allied Telesyn AT-9924T/4SP version 2.6.6-00 11-Nov-2004
SysContact

SysLocation

SysName

SysDistName

SysUpTime
620 ( 00:00:06 )
Boot Image      : 99b104.fbr size 1026588 11-Nov-2004
Software Version: 2.6.6-00 11-Nov-2004
Release Version : 2.6.6-00 11-Nov-2004
Patch Installed : NONE
Territory       : usa
Help File       : 89-272a.hlp

PSU1: (FAN)     Fan: Normal
PSU2: (AC)      Fan: Normal  Temp: Normal  Power: Normal

Current temperature : Normal

FAN
-----
Main fans                Normal
Accelerator fan 1        Normal
Accelerator fan 2        Normal
-----

Configuration
Boot configuration file: flash:boot.cfg (exists)
Current configuration: flash:boot.cfg

Security Mode   : Disabled

Warning (2048284): No patches found.

```

The first section of the output shows information about boards installed in the switch. There are details about the switch base card, the accelerator card if installed, and the type of power supply unit or fan-only module. Both the part names and serial numbers of the base card and accelerator card are displayed.

Record the details of the base card and the network processor accelerator card for later reference. If you have questions or problems with the network processor accelerator card at any time, contact your authorised distributor or reseller and supply the serial numbers for them.

If there is no entry for the accelerator card, then the switch's boot process has not detected the card. The most likely cause is that the card is not correctly plugged into the slot on the switch's base board.

Displaying information about the card

To display information about the status and memory of a network processor accelerator card on AT-8900 and AT-9924T/4SP switches, use the **show switch accelerator** command.

The following figure is an example of output from the **show switch accelerator** command.

```
Switch Accelerator Configuration
-----
Hardware Type ..... AT-ACC01
Mode ..... IPv6 Acceleration
Status ..... IPv6 active
Search memory size ..... 128 Mb
Counter memory size ..... 2 Mb
-----
```

Memory Options

The following memory expansion options are available:

- **CompactFlash Card**—AT-8900 and AT-9900 switches have a slot on the front panel
- **Dual In-line Memory Module (DIMM)**—installed in AT-8900, AT-9900, and AT-9900s switches

CompactFlash Card

CompactFlash (CFlash) cards are a memory expansion option for AT-8900 and AT-9900 switches. Data such as releases, patches, and configurations can be stored on these cards, and files can be manipulated with the command line interface (CLI). However, release and patch files cannot be run directly from the card, but must be loaded into either NVS or onboard flash.

Important Anyone with a compliant reader can read CFlash cards so do not keep sensitive data on them.

Approved CFlash cards

The following CompactFlash cards are approved for use with AT-8900 and AT-9900 switches:

- AT-CF032A-*nnn* 32 MB
- AT-CF064A-*nnn* 64 MB (AT-9900 only)
- AT-CF128A-*nnn* 128 MB

Where *n* is the number of cards in a package, less than 1000. A package containing one card is 001.

For the latest list of approved CFlash cards, contact your authorised distributor or reseller.

CFlash cards used with the switch must support a hardware access time of no more than 100 nanoseconds. If a card does not meet this requirement, it may not work.

Inserting and removing a CFlash card

You can insert a card into the CompactFlash slot at any time; it takes about two seconds to initialise. The following CLI message confirms that a card has been inserted:

```
Info (1106257): Compact flash card inserted.
```

The following message confirms that the card is ready to use:

```
Info (1106268): Compact flash card initialisation successful.
```

The following message means that the CFlash card is not compatible with the switch:

```
Info (3106300): Compact flash card initialisation
unsuccessful.
```

Important When data is being written to or read from the card, the CF LED on the front panel of the switch is green. Do **not** remove the card when it is active or you will corrupt the data. Wait until the LED is off before ejecting the card.

Displaying data about a CFlash card

To display information about the basic state of a CompactFlash card, including card size, file count, and serial number, insert the card and enter the command:

```
show cflash
```

To display cluster ranges on a card, insert the card and enter the command:

```
show cflash test
```

The following figure is an example of output from the **show cflash test** command when no test is running.

```
Clusters available for testing
  Ranges:
    [42645--61944]
  Number of free clusters = 19300
  Number of ranges       = 1
  Number of used clusters = 42645
```

Testing a CFlash card

To test a card, insert it in the CF slot and enter the command:

```
enable cflash test start=startnumber end=endnumber
```

where *startnumber* and *endnumber* are positive integers within a cluster range. The end number must be higher than the start number. Cluster ranges are displayed in the output of the **show cflash test** command.

The test software reads the file allocation table and displays a list of free sectors. Sectors can be tested as single sectors or as a range. The test consists of a write/read/verify cycle.

To stop the test, use the **disable cflash test** command. To display test results while a test is in process, enter the **show cflash test** command.

The following is example output from the `show cflash test` command when a test is running.

```

Test Progress
  Starting cluster           = 700
  Ending cluster             = 1700
  Current cluster            = 1185

  Passed clusters number    = 485
  Passed sectors number     = 1940

  Failed clusters number    = 0
  Failed sectors number     = 0
  Used Clusters encountered = 0

  Duration.....            4417 ms

```

Error messages are displayed when a file write fails. Failure could be due to the card being removed or an error in the card itself. For information about CFlash commands, see the *Managing the File System* chapter in the Software Reference.

Dual In-line Memory Module (DIMM)

Synchronous DRAM (SDRAM) is provided by a single DIMM for AT-8900, AT-9900, and AT-9900s switches. Only DIMMs supplied by Allied Telesyn have been tested and approved for use. **Using unapproved DIMMs may cause unreliable operation and will invalidate the warranty for the switch.**

AT-9924T and AT-9924SP switches

The following DIMMs have been approved for use with AT-9924T and AT-9924SP switches:

- AT-SD128A-00 128 MB SDRAM (factory installed)
- AT-SD256A-00 256 MB SDRAM (upgrade)

AT-9924T/4SP switch

The following DIMMs have been approved for the AT-9924T/4SP switch without the AT-ACC01 network processor accelerator card:

- AT-SD256A-00 256MB SDRAM (factory installed)
- AT-SD512A-00 512MB SDRAM (upgrade)

For an AT-9924T/4SP switch with an AT-ACC01 network processor accelerator card, the following DIMM is required:

- AT-SD512A-00 512MB SDRAM (factory installed when the switch is ordered with an AT-ACC01 fitted)

AT-9924Ts switch

The AT-9924Ts switch is shipped with a 512 MB SDRAM DIMM; no upgrades are available.



Warning Only authorised service personnel should install DIMMs. Opening the switch's lid may cause personal injury from electric shock and could damage the switch.

Verifying DIMM installation

The switch is unlikely to boot unless the DIMM is correctly installed. If the switch does boot but you suspect the DIMM is malfunctioning, display system information by using the `show system` command. See [“Verifying installation” on page 34](#) for output.

The size of DRAM is in the memory section of the output. If the DRAM size is less than the size of DIMM that has been installed, then the switch has not detected the DIMM. The most likely cause is that the DIMM connector is not correctly plugged into the slot.

Record the switch's serial number and revision details for later reference. If you have questions or problems with the DIMM at any time, contact your authorised distributor or reseller and supply these serial numbers.

Expansion Options

The following expansion options are available:

- **SFP ports**
- **XFP ports**
- **RJ-45 ports**

Optional expansion modules make the AT-9900s one of the most flexible switches available. They provide economical combinations of speed and port density. Two 20 Gbps bays in the front of the AT-9900s switch allow quick and easy installation.

Refer to the *Expansion Module Installation Guide* for AT-9900s switches for more information about each model. For the latest list of approved transceiver modules, contact your authorised distributor or reseller.

SFP ports The following SFP modules are approved for use with the AT-8900 and AT-9900 switches, including the AT-A61 1000BASE-X expansion module for the AT-9900s switch.

Product No.	Media Type	Description
AT-SPTX	10/100/1000BASE-T	Copper, 100m at 1000Mbps, RJ-45 connector (except for AT-9924SP)
AT-SPSX	1000BASE-SX	850nm, 2m to 500m with 50/125 μ m MM fiber, 2m to 275m with 62.5/125 μ m MM fiber, LC connector
AT-SPLX10	1000BASE-LX	1310nm, 2m to 10km with 9 μ m SM fiber, 2m to 550m with 50 μ m MM fiber, 2m to 550m with 62.5 μ m MM fiber, LC connector
AT-SPLX40	1000BASE-LX	1310nm SM fiber up to 40km, LC connector
AT-SPLX40/1550	1000BASE-LX	1550nm SM fiber up to 40km, LC connector
AT-SPZX80	1000BASE-ZX	1550nm, 80km with 9 μ m SM fiber, LC connector
AT-SPZX80/xxxx	1000BASE-ZX CWDM	Wavelengths of 1610nm to 1470nm (20nm intervals) and 1310nm, 80km with 9 micron SM fiber, LC connector. Where xxxx can be: 1610 1590 1570 1550 1530 1510 1490 1470

XFP ports The following XFP modules are approved for use with the AT-A60 10Gigabit Ethernet expansion module for the AT-9900s.

Product No.	Media Type	Description
AT-XPSR	10GBASE-SR	850nm short-haul transmission, 300m with MMF
AT-XPLRM	10GBASE-LRM	1310nm short-haul transmission, 300m with MMF
AT-XPLR	10GBASE-LR	1310nm medium-haul transmission, 10km with SMF
AT-XPER40	10GBASE-ER	1550nm long-haul transmission, 40km with SMF

RJ-45 ports The 12-port RJ-45 expansion module, model AT-A62, features the following:

- two rows of 6 RJ-45 ports
- gigabit ports that support speeds of 10/100/1000Mbps
- status LEDs
- two 16MByte DDR-SDRAM for packet buffering
- cable fault detection and distance-to-fault diagnostics are available for RJ-45 Ethernet ports (see the *Test Facility* chapter in the Software Reference for the switch)

Test Facility

The test facility is a hardware test tool in AT-8900, AT-9900, and AT-9900s software. Its primary function is to validate that there are no hardware problems after installation of the switch or expansion options. You can also use it as a troubleshooting tool, but it is just one of many such tools. You could consider the test facility to be a specialised interface module, such as PPP or Frame Relay, where the interfaces under test are dedicated to the test facility.

Before you use the test facility, disable configurations by using the **set configuration=none** command, and restart or reboot the switch. For more information about the test facility, see the *Test Facility* chapter in the Software Reference.

Testing Ethernet LAN Ports

A crossover cable is required to run an Ethernet LAN test. How to make a suitable cable is described in [“Cables for RJ-45 Ethernet LAN Interfaces” on page 30](#). To start the test, loop a four-pair crossover or straight-through cable between two RJ-45 ports and enter the **enable test interface=all** command. Interfaces connected by crossover cables are tested. If a test fails, contact your authorised distributor or reseller.

To display test results, use the **show test** command. To display detailed output with frame counts, use the **show test count** command. For example output from these commands, see the *Test Facility* chapter in the Software Reference. This chapter also contains information on how to test other interfaces.

Diagnostics

Software for AT-8900, AT-9900, and AT-9900s switches includes a set of diagnostic programs that perform basic checks of all system components. These diagnostics do not run with normal operating code and require that the system be totally dedicated to their use. The switch does **not** perform switching operations when diagnostics are running.

Caution Diagnostics are designed to be run by service personnel only. This section is **not** intended as a guide to diagnostics software. Detailed knowledge of how the switch hardware functions is necessary in order to effectively use diagnostic programs. For more information, contact your authorised distributor or reseller.

Enabling diagnostics mode

1. Connect a terminal to the RS-232 terminal port (ASYN0).

Use a terminal cable to connect a terminal to the RS-232 port (ASYN0) on the switch. For more information on terminal cables, see [“RS-232 Terminal and Modem Cables” on page 29](#).

Set the terminal communication parameters as follows:

- Baud rate: **9600**
- Data bits: **8**
- Parity: **None**
- Stop bits: **1**
- Flow control: **Hardware**

2. Restart the switch.

To restart the switch, use a small diameter pin to press the recessed Reset button on the front panel of the switch. You can also log in at the terminal and enter the command:

```
restart reboot
```

How to log in is described in the Installation and Safety Guide.

3. Enable diagnostics mode during self-tests at startup.

The switch pauses briefly during its self-tests to allow an override.

For AT-8900 and AT-9900 switches, the following prompt is displayed:

```
Force EPROM download (Y)?
```

For AT-9900s switches, the following prompt is displayed:

```
Boot fallback software (Y)?
```

Press **Ctrl+D** to enable diagnostics mode. Press **Ctrl+D** **once only** to ensure you send no other characters to the switch.

One of the following menus is displayed depending on the switch model. When you see the menu, you know that the terminal is connected.

Menu for AT-8900 and AT-9900 switches

```
* * * Diagnostic Mode * * *

version: Nov 10 2004 11:08:34

Main Menu:
0. Restart
1. Full RAM test
2. ROM checksum test
5. Battery backed RAM test
7. Display PCI devices (not shown for AT-8948 models)
8. Watchdog test (not shown for AT-8948 models)
Enter selection ==>
```



Caution If you have an EPROM chip and you perform a full flash test or erase flash, you will delete all configuration and release files. We recommend that you know how to reload these files before you erase flash or perform a flash test.

Menu for the AT-9900s switch

```
Diagnostics Menu:
0. Restart
1. Full RAM test
2. Bootloader ROM checksum test
3. Full FLASH test
4. Erase FLASH file system
5. Battery backed RAM test
6. Quick RAM test
8. Quit and continue booting
Enter selection ==>
```



Caution If you perform a full flash test or erase flash, you will delete all configuration files and the product software that runs the switch. We recommend that you know how to reload these files before you erase flash or perform a flash test.

Running a diagnostic program

There are several sub-menus that cover the available options. Control keys for diagnostic operations are in the following table.

Key	Function
Q	Quits tests that are running. Displays a banner page or restarts, depending on the switch.
S	Prints a summary of test results thus far for AT-9900 switches only.

To restore the switch to normal operation, use a small diameter pin to press the recessed reset button on the front panel of the switch, or press 0 to restart.

Troubleshooting

This section provides information on how to troubleshoot AT-8900, AT-9900, and AT-9900s switches to resolve the following basic problems:

- **L/A LED on a port is off**
- **Power LED is off**
- **Fault LED is on**

What to check first

- Check power cord connections.
- Check that the power supply voltage is stable.
- Check that the correct data cables are used and that their connections are secure.
- Make sure that other network devices work properly.
- Use the **show install** command to check that the latest software release is loaded. The Software Reference describes how to obtain the latest software release.
- If the switch malfunctions, reboot it. Either use a small diameter pin to operate the recessed Reset button on the switch's front panel or enter the **restart reboot** command. Alternatively, shut down and restart the switch at either the main power source (AC models) or use the Run/Standby switch on the PSU (DC models).

L/A LED on a port is off

If the Link/Activity LED is off, it may indicate the following:

- a loose data cable
- the device at the other end of the connection does not work properly or is turned off
- the data cable is not wired correctly
- the network administrator has manually disabled the port through the software
- the port's selected transmission mode does not match that of the attached device

Follow these suggestions to resolve the problem:

1. Make sure the data cable connections are secure.
2. Make sure the device at the other end of the connection is powered on and works properly.
3. Check that the data cable is wired correctly.
4. If you can, log in and check the port status. How to log in is described in the Installation and Safety Guide.
5. If the port is enabled, make sure the transmission speed matches that of the connected device (autonegotiating, full or half-duplex).
6. If the port is disabled, someone disabled it with the software. Find out why before you enable it.

Power LED is off If the power LED is off, it may indicate the following:

- a loose power cord
- a power supply failure
- a FOM is installed in that bay

Follow these suggestions to resolve the problem:

1. Check that the power cord connections are secure.
2. Check that all switches and circuit protection devices are in the “on” position.
3. Ensure that the supply voltage is within the operational range:
 - AC models: 100 V to 240 V AC, 47 Hz to 63 Hz
 - DC models: 40 V to 60 V DC

Fault LED is on If the fault LED is on, it may indicate the following:

- there is a problem with the switch
- the switch or management software is malfunctioning
- a hardware fault is preventing switch startup

Follow these suggestions to resolve the problem:

1. Read the descriptions of LED flashing sequences for explanations of what to do (see “Switch LEDs” on page 10).
2. Reset the switch. Use a small diameter pin to press the recessed reset button on the front panel of the switch.
3. If you were attempting to download software or manage the switch over the RS-232 terminal port, check that connections between the terminal port and local terminal or PC are secure.

If you cannot access the switch software because of a faulty RS-232 terminal port connection, you can still manage the switch by using Telnet or SNMP until the problem is resolved.

4. Download the most current software. The Software Reference describes how to obtain the latest software product.

Additional resources Other sources of useful troubleshooting information are:

- www.alliedtelesyn.com
- the Software Reference, especially the *Test Facility* chapter

For More Information

Document sets The Documentation and Tools CD-ROM bundled with each switch contains the complete document set for AT-8900, AT-9900, and AT-9900s Series switches and their power supply units, as well as tools for switch management. The CD-ROM includes the following:

- Software Reference, which provides detailed information on configuring the switch and its software
- Installation and Safety Guide for the switch, which describes how to install the switch and includes important statutory and safety information
- Installation Guide for the power supply unit and fan, which describes how to install a PSU and FOM in the switch

You can also download these documents and updates from www.alliedtelesyn.com.

Contacting us With locations covering all of the established markets in North America, Latin America, and Europe, Allied Telesyn provides localized sales and technical support worldwide. To find the representative nearest you, visit us on the Web at www.alliedtelesyn.com.