

AT-8800 SERIES SWITCH

HARDWARE REFERENCE

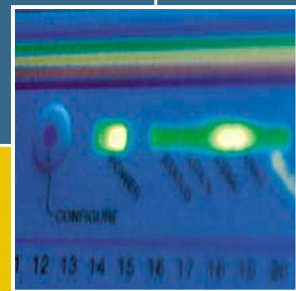
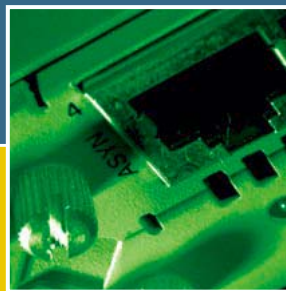
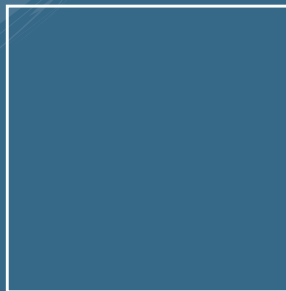

AT-8800 Series Hardware Reference
Document Number C613-03066-00 REV A.

Copyright © 2003 Allied Telesyn International, Corp. 19800 North Creek Parkway, Suite 200, Bothell, WA 98011, USA.

All rights reserved. No part of this publication may be reproduced without prior written permission from Allied Telesyn.

Allied Telesyn International, Corp. reserves the right to make changes in specifications and other information contained in this document without prior written notice. The information provided herein is subject to change without notice. In no event shall Allied Telesyn be liable for any incidental, special, indirect, or consequential damages whatsoever, including but not limited to lost profits, arising out of or related to this manual or the information contained herein, even if Allied Telesyn has been advised of, known, or should have known, the possibility of such damages.

All trademarks are the property of their respective owners.

Contents

Contents	1
Models Covered By This Reference	2
Why You Should Read This Reference	2
Where To Find More Information	2
Hardware Description	3
Switch Overview	3
AT-8800 Series Switch Models	6
AT-8824	6
AT-8848	6
Online Documentation	6
Accessing the CD-ROM and Online Documentation	7
AT-TFTP Server	7
Using Windows Terminal and Windows Hyperterminal	8
Switch Start-up	11
To log In	11
To access help	12
Start-up Procedures	12
RS-232 Terminal Port (ASYNO)	15
Useful Cables	16
RS-232 Terminal and Modem Cables	16
Cables for RJ-45 Ethernet LAN Interfaces	17
Test Facility	19
Ethernet LAN Port Tests	19
Other Interface Tests	21
Redundant Power Supply (RPS)	21
AT-RPS8000	22
Port, Connector, and Cable Combinations	24
Troubleshooting	24
LEDs and What They Mean	24
Check these first	25
Some common problems and how to solve them	26
Expansion Options	27
Gigabit Interface Converters (GBICs)	27
Dual In-line Memory Modules (DIMMs)	28
Restricted Procedures	29
Installing DIMM	29
Testing DIMM	31
Diagnostics	32
Contacting Us	34

Documentation Roadmap

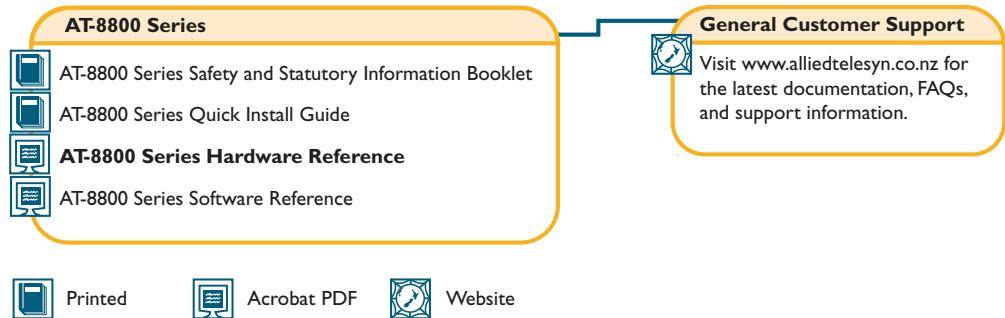

Models Covered By This Reference

This Hardware Reference includes information on the following products:

- AT-8824
- AT-8848

The latest AT-8800 Series Hardware Reference can be found at www.alliedtelesyn.co.nz/support/at8800/

Why You Should Read This Reference

This Reference provides hardware related information for AT-8800 Series switches.

The Reference has two primary aims:

1. To familiarise you with the hardware features of AT-8800 Series switches.
2. To assist you with setting up and maintaining your AT-8800 Series switch.



This Reference does not cover software configuration or software installation procedures. For information on software, refer to the AT-8800 Series Software Reference.

Where To Find More Information

The Documentation and Tools CD-ROM bundled with each switch contains the complete Document Set for AT-8800 Series switches and their expansion options, as well as tools for switch management. This includes:

- The *AT-8800 Series Statutory and Safety Information* booklet, which includes important safety information and statutory declarations for AT-8800 Series switches.

- The *AT-8800 Series Quick Install Guide*, which outlines the procedure for installing switch units.
- The *AT-8800 Series Software Reference*, which provides detailed information on configuring the switch and its software.
- AT-TFTP Server for Windows, for downloading software releases.
- Adobe Acrobat Reader, for viewing online documentation.
- Microsoft Internet Explorer.

These documents can also be downloaded from the AT-8800 Series Support Site at www.alliedtelesyn.co.nz/support/at8800/

Hardware Description

This section provides an overview of hardware features for the AT-8800 Series, as well as hardware descriptions of each model.

Switch Overview

Developed to meet the exceptionally high performance demands of low to mid-range applications, AT-8800 Series switches deliver hardware-based low-latency high-bandwidth wire speed Layer 2 and 3 switching, in a robust 1U platform.

With GBIC and 10/100/1000BASE RJ-45 port options bridging traditional copper/fibre divides, and hardware expansion options such as DIMM, the AT-8800 Series is a versatile and powerful switching solution for rapidly evolving networks.

Dimensions

Table 1: Dimensions for AT-8824 and AT-8848.

	AT-8824	AT-8848
Height	1U - 44 mm (plus 5.5 mm if the rubber feet are used).	1U - 44 mm (plus 5.5 mm if the rubber feet are used).
Width	440 mm (excluding rack-mounting brackets).	440 mm (excluding rack-mounting brackets).
Depth	350 mm.	350 mm.
Weight	Not more than 6 kg excluding power cord.	Not more than 6 kg excluding power cord.

Mounting System

- 1U rack mounting

Environmental Conditions

- Operating temperature range: 0 to 40° C (32 to 104° F)

- Storage temperature range: -20 to 60° C (-4 to 140° F)
- Relative humidity range: 5 to 95% non-condensing

Regulatory Standards

AC models

- AS/NZS3260
- CNS 13438 Class A
- BSMI
- VCCI Class A
- EMC: EN55022 class A, FCC class A, and VCCI class I
- Immunity testing to EN55024: EN61000-3 levels 2 (Harmonics), and 3 (Flicker). EN61000-4 levels 2 (ESD), 3 (susceptibility), 4 (fast transients), 5 (power surge), 6 (RF immunity), and 11 (Voltage dips and sags).
- Safety: UL60950, CAN/CSA-C22.2 NO. 60950-00, EN60950, ACA TS001
- Certification: UL, cUL, TUV

LEDs

- Port and System status LEDs
- For a complete list of LEDs and their functions, see “LEDs and What They Mean” on page 24.

Power Supply Unit

AC models

- Universal 100/240 VAC 50/60 Hz input
- Redundant DC Power connection

Maximum Current Loads

AC models

- Maximum continuous current draw, 0.7A at 240V, 1.5A at 100V
- Maximum inrush current (cold start at 25° C /77° F), 50A at 115V

Switching Cores

- Application-Specific Integrated Circuit (ASIC) switch chip
- Non-blocking L2 and L3 IP Switching
- 8 k entry forwarding address database
- 32 MByte SDRAM packet buffer

Processing Core

- 400 MHz RISC Processor
- 64, 128 or 256 MBytes Synchronous DRAM on DIMM
- 16 MBytes of fixed flash (expandable to 32 MBytes)
- 128 kBytes of SRAM (NVS)

- Battery backed real time clock (RTC)
- 32/33 PCI bus
- Silicon ID chip storing serial number, board ID, and MAC address

Asynchronous Serial Ports

- Up to 115 kbps
- Hardware-flow control
- RJ45 with Cisco pinout
- RJ-45 cable and RJ-45 to DB9 adapter supplied

PCI Accelerator Card (PAC) Slot

- For optional 32-bit PCI based hardware Encryption and/or Compression Card, a PAC interface connection is provided

Online Documentation

This section provides a step-by-step guide to accessing online documentation. Adobe Acrobat Reader must be installed to view online documentation.

Accessing the CD-ROM and Online Documentation

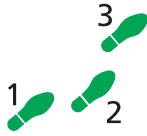

Follow these steps to access the CD-ROM and online documentation:

1. **Insert the Documentation and Tools CD-ROM in the CD-ROM drive.**

2. **If the Welcome screen does not appear.**

Select "Run" from the Start Menu (Windows 95, 98, 2000 or NT 4.0).

Type d:\start.exe (where d: is the CD-ROM drive letter) and click OK.

3. **To view a document.**

Click on the document title.

4. **To navigate around PDF documents.**

Use the toolbar buttons, keyboard shortcuts, or commands from the Document menu to page through the document.

Click on a bookmark, thumbnail or hypertext link to jump to a specific section or topic.

Use the Search command to search for keywords or phrases.

For more information about using the Adobe Acrobat Reader, select "Reader Guide" from the Help menu.

5. **To install any of the tools included on the CD-ROM.**

Click on a link in the Welcome screen.

AT-TFTP Server

This section provides information on how to access and use AT-TFTP Server. AT-TFTP Server can be used to transfer configuration files as well as to download software patches and releases.

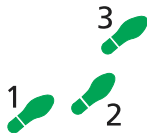

To use AT-TFTP Server, follow these steps:

1. **If AT-TFTP Server has not yet been installed.**

Install it now from the AT-8800 Series Documentation and Tools CD-ROM.

Choose AT-TFTP Server from the Start > Programs > Allied Telesyn > AT-TFTP Server menu.

2. **To set preferences for the AT-TFTP Server.**

Select "Options" from the File menu to display the "Set Preferences" dialog box.

The "Default file transfer directory" field specifies the directory that AT-TFTP Server will read from or write to for file requests that do not include a directory specification.

To prevent unauthorised access to private directories, enter a path name in the "Restrict to directory" field. AT-TFTP Server will use only the specified directory, even if file requests contain references to other directories.

Select "Read only" to prevent files being written to the PC. To use the PC to archive scripts created using the switch's CREATE CONFIG command, select "Read Write".

Make any required changes and click "OK".

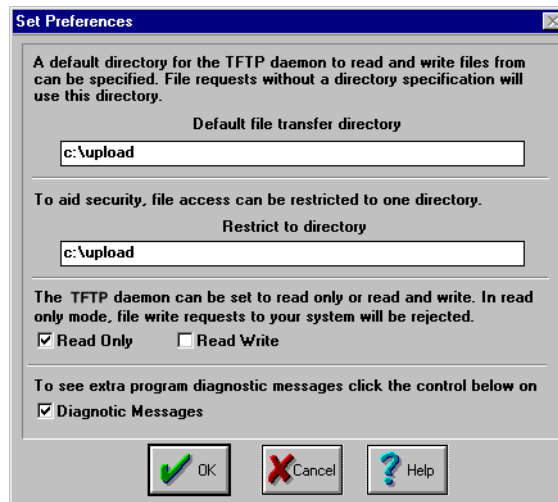

3. To load a file from AT-TFTP Server to the Switch.

On a terminal connected to the RS-232 Terminal Port (ASYN0), type the command:

```
LOAD METHOD=TFTP FILE=filename SERVER=ipadd DEST=FLASH
```

where *filename* is the name of the file to download and *ipadd* is the IP address of the PC running AT-TFTP Server.

4. To save a TFTP Server log.

Select "Save As" from the File menu.

TFTP requests are logged to the AT-TFTP Server main window.

Using Windows Terminal and Windows Hyperterminal

You can use a PC running terminal emulation software as the manager console, instead of a terminal. There are many terminal emulation applications available for PCs, but the most readily available are the Terminal and HyperTerminal applications included in Microsoft Windows 95, 98, 2000, and Windows NT 4.0. In standard Windows installations, HyperTerminal is located in the Start > Programs > Accessories menu.

The key to successful use of terminal emulation software with the switch is to configure the software and switch with matching communications parameters. The following procedures describe how to configure Windows Terminal and HyperTerminal for the default RS-232 ASYN0 settings on the switch, but the same principles apply to other terminal emulation programs.

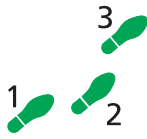

To configure Windows HyperTerminal for Windows 95, 98, 2000, & NT 4.0.

1. In Windows, select:

- Programs > Accessories > HyperTerminal.
- Double-click the Hypertrm.exe icon.

2. In the Connection Description dialog box:

- Enter a name for the connection (e.g., AT88001)
- Select an icon from the scrolling list.
- Click "OK".

3. In the Phone Number dialog box:

From the "Connect using:" drop-down list, select:

- "Direct to Com *n*" Where "COM *n*" is the COM port on the PC used to connect to the switch.
- Click "OK".



4. In the COM*n* Properties dialog box, set:

- Bits per second: 9600.
- Data bits: 8.
- Parity: None.
- Stop bits: 1.
- Flow control: Hardware.
- Click "OK".

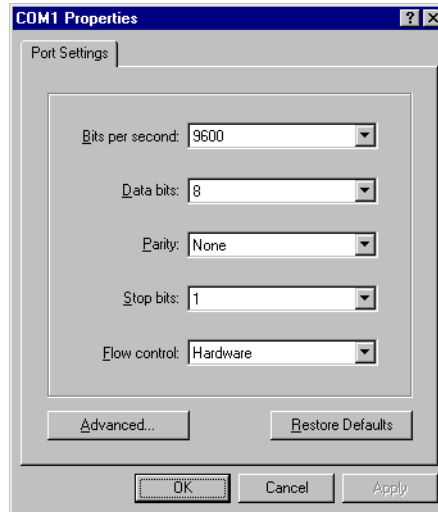

5. From the File menu, select:

- “Properties”

In the Connection Properties dialog box, click the Settings tab and set:

- “Function, arrow, and ctrl keys act as” to “Terminal keys”
- “Emulation” to VT100.

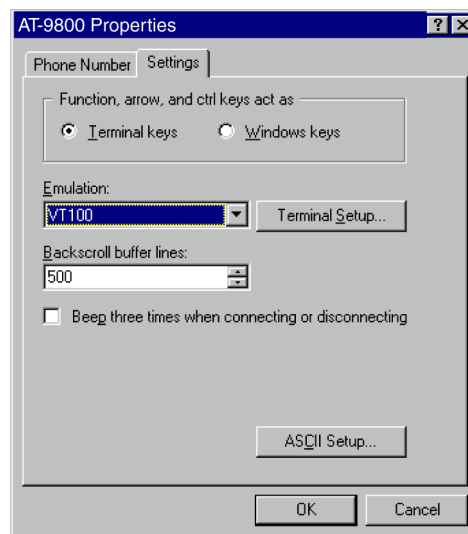

6. Click “ASCII Setup” to display the ASCII Setup dialog box. Uncheck:

- “Echo typed characters locally”.
- “Append line feeds to incoming line ends”.

Set other parameters as required.

- Click “OK” twice to close all dialog boxes.

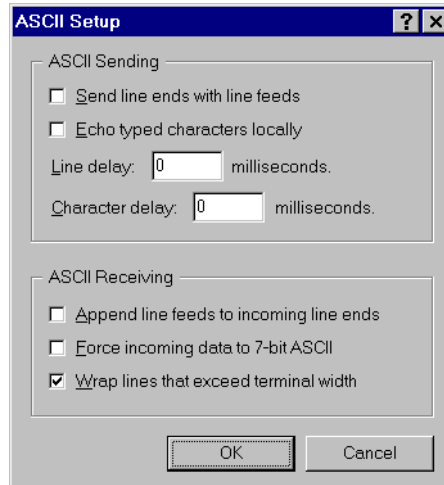

7. Save the current session. From the File menu, select:

- "Save".

This creates a connection icon with the name you assigned in the HyperTerminal group. To use the configuration:

- Double-click the connection icon in the HyperTerminal group.

When the HyperTerminal window appears, press:

- [Enter] a couple of times.

The switch's log in prompt will appear.

Switch Start-up

This section outlines the log in and start-up procedures for your switch. Although the switch will perform basic switching operations without being configured, you will need to go through these log in and start-up procedures if you wish to configure the switch and access its full layer 3 switching capabilities.

To log In

To log in you must first connect the switch to a terminal or PC. This can be done using the RS-232 Terminal Port (ASYN0). A terminal cable suitable for use with ASYN0 is supplied with each switch.

Using the supplied terminal cable, or a cable you have made by following the instructions in "Useful Cables" on page 16, connect your terminal or PC to ASYN0.

Set the communication parameters on your terminal or terminal emulation program to:

- Baud rate: 9600
- Data bits: 8
- Parity: None

- Stop bits: 1
- Flow control: Hardware

See “Using Windows Terminal and Windows Hyperterminal” on page 8 for more information on configuring emulation software.

Ensure that any power switches are in the On position and that the switch is receiving power.

After the switch has booted, the log in prompt appears. If the log in prompt doesn't appear, press [Enter] two or three times.

When the switch boots for the first time it automatically creates an account with manager privileges. The account has the log in name “manager” and the password is “friend”.

At the log in prompt, enter the log in name and password.

```
Log in: manager
```

```
Password: friend
```

The switch's command prompt appears and you can now configure the switch using the command line interface.



Change the password as soon as possible. Leaving the manager account with the default password is a serious security risk. Make sure that you remember the new password as there is no way to retrieve it if it is lost.

Use the following command to change the account password:

```
set password
```

See the *AT-8800 Series Software Reference* for more information on configuring the switch.

To access help

Before help is used for the first time, the help files must be defined.

To define the files, enter:

```
set help=help-filename
```

where *help-filename* is the name of a help file stored in flash.

To see a list of files stored in flash, enter:

```
show file
```

Help files have an HLP extension.

To display a list of help topics, enter:

```
help
```

To display help on a specific topic, enter:

```
help topic
```

Alternatively, type a question mark (?) at the end of a partially completed command to see a list of valid options.

Start-up Procedures

When the switch starts up following either a power cycle or an operator-initiated reboot (using the Reset button or RESTART command), a series of start-up messages is sent to the terminal or PC connected to ASYN0 (Figure 4 on page 13).

Figure 4: Switch start-up messages.

```

INFO: Self tests beginning.
INFO: RAM test beginning.
PASS: RAM test, 131072k bytes found.
INFO: BBR tests beginning.
PASS: BBR test, 512k bytes found.
INFO: Self tests complete
INFO: Downloading switch software.
Force EPROM download (Y) ?
INFO: Initial download succeeded
INFO: Executing configuration script <boot.cfg>
INFO: Switch startup complete

Manager >

```

After the self tests are complete, the manager is given the option of forcing a mandatory boot from the EPROM (Flash) release. The message:

```
Force EPROM download (Y)?
```

is displayed on the terminal or PC connected to ASYN0 and the switch pauses. If a key is not pressed within a few seconds, the start-up process will continue and all steps in the sequence will be executed. Pressing selected keys on the terminal immediately after the “Force EPROM download” message is displayed will change the switch start-up process (Table 2 on page 13).

Table 2: Switch start-up sequence keystrokes.

Pressing key...	Forces the switch to...
[Y]	Load the EPROM release, with no patch.
[S]	Start with the default configuration. Any boot script is ignored.
[Ctrl/D]	Enter diagnostics mode.

During the start-up process the switch will generate four different types of messages. All messages are preceded by one of the words INFO, PASS, FAIL, or ERROR. The significance of these words is shown in Table 3 on page 13.

Table 3: Switch start-up message classes.

Message	Meaning
INFO	An action will be taken by the system.
PASS	A test has been completed successfully.
ERROR	An error message that a test has failed, but the system will continue to operate.
FAIL	An error message that a fatal error condition has caused the system to halt in an unrecoverable fashion.

The possible messages and their meanings are:

```
INFO: Self tests beginning.
```

The code loader tests are about to begin.

```
INFO: RAM test beginning.
```

The RAM tests are about to begin.

```
PASS: RAM test, 65536k bytes found.
```

The RAM test passed, and the indicated amount of memory was found and will be used by the switch.

ERROR: RAM test 5. Error address = 00345678.

A RAM test failed, at the given address. In the example, it was the fifth test run. The RAM test repeats until it passes, so a number of messages like this may appear. This fault means that the memory system is faulty. If the fault continues, contact your authorised Allied Telesyn distributor or reseller immediately.

INFO: BBR tests beginning.

The BBR battery tests are about to begin.

PASS: BBR test. Battery OK.

The BBR battery tests passed.

PASS: BBR test, 512k bytes found.

The BBR size/location test passed, with the indicated amount of BBR found.

FAIL: BBR test. Error address = 12345678.

The BBR size/location test failed at the given location. The test at this location failed, indicating the end of memory, but a valid location was discovered in the 255 long words following this location. The BBR system will need to be replaced. Contact your Authorised Allied Telesyn distributor or reseller.

FAIL: BBR test, only 16k bytes found.

The BBR size/location test completed, but only the displayed amount of memory was found. This amount is less than the minimum required to run the switch software.

INFO: Self tests complete.

The start-up tests have finished.

INFO: Downloading switch software.

The process of downloading the switch software and vector table from ROM is about to begin.

ERROR: Code load retried.

FAIL: Code load failed.

The load of the code from ROM to RAM failed. The load is retried a number of times. Each time a failure occurs, the ERROR message is displayed. If the maximum number of attempts is reached, the FAIL message is displayed.

INFO: Initial download successful.

The start-up tests and download are complete, and the switch software is about to be started.

INFO: Executing configuration script <script-name>

The configuration commands stored in <script-name> are being executed. If an error is found in the script, one or more ERROR messages will be displayed.

INFO: Switch startup complete.

The start-up process is complete and the switch will now perform basic switching operations. Further configuration will be necessary if you wish to

access the switch's full layer 3 switching capabilities. See your *AT-8800 Series Software Reference* for detailed information on configuring the switch.

RS-232 Terminal Port (ASYN0)

This section introduces the switch's RS-232 Terminal Port (ASYN0), including its pin assignment and purpose.

The RS-232 ASYN0 Terminal Port is used to connect the switch to a management device for initial configuration and switch management tasks. This allows the switch's software to be accessed from a terminal, a PC running terminal emulation software. You can also use ASYN0 to establish a network connection from a remote site using SLIP and a modem.

ASYN0 has an RJ-45 socket with a Cisco pinout. This requires the use of a straight-through RJ-45 cable with an RJ-45 DB9F connector when connecting the switch to a terminal or PC. The socket is wired as a DTE and the pin roles are shown in Figure 5 on page 15 and listed in Table 4 on page 15.

See "Useful Cables" on page 16 for more information on suitable cables to use with ASYN0.

Figure 5: RS-232 Terminal Port Pin Numbers

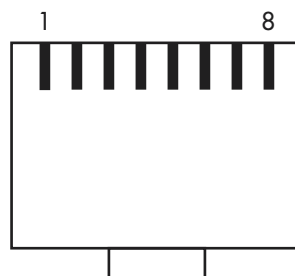

Table 4: Internal DTE pin roles.

Pin	Role
1	RTS
2	DTR ¹
3	TXD
4	GND
5	GND
6	RXD
7	DSR ¹
8	CTS

1. DTR and DSR are connected together but have no other internal connection.

Useful Cables

This section describes how to make management, test, and network cables for use with the switch's RS-232 (ASYNO) and RJ-45 interfaces.

RS-232 Terminal and Modem Cables

Table 5 on page 16 list the terminal and modem cables described in this section.

Table 5: Terminal and modem cable descriptions.

Cable type	Description
RS-232 RJ-45 to DB9 female terminal cable	Figure 6 on page 16
RS-232 RJ-45 to DB9 male modem cable	Figure 7 on page 17

Figure 6 on page 16, and Figure 7 on page 17 show how to wire cables to connect a standard VT100 compatible terminal, or a modem, to ASYN0.

Figure 6: Pin wiring diagram for a standard DB9 male to female terminal cable.

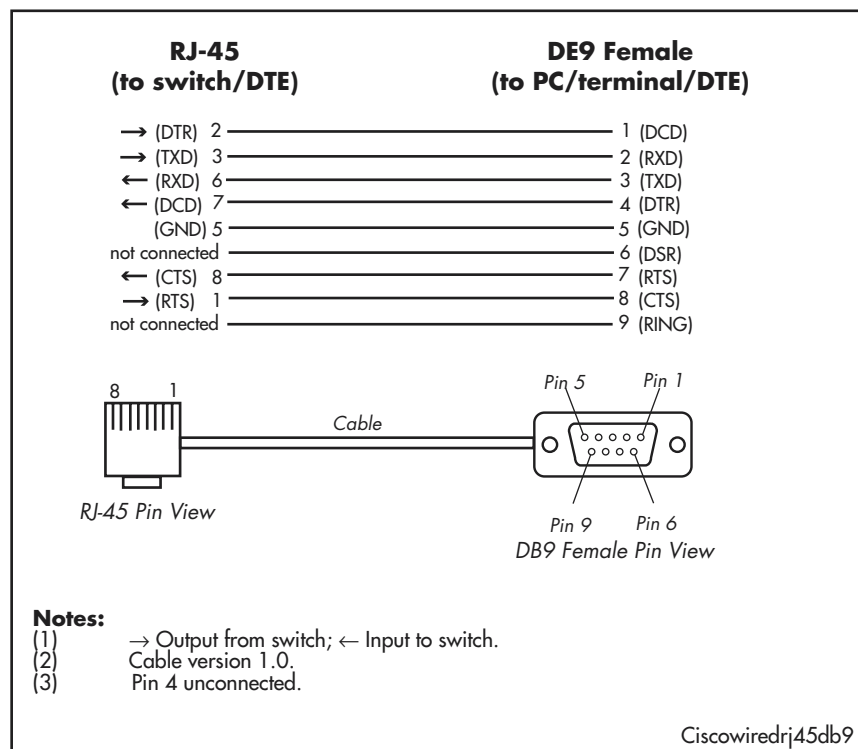
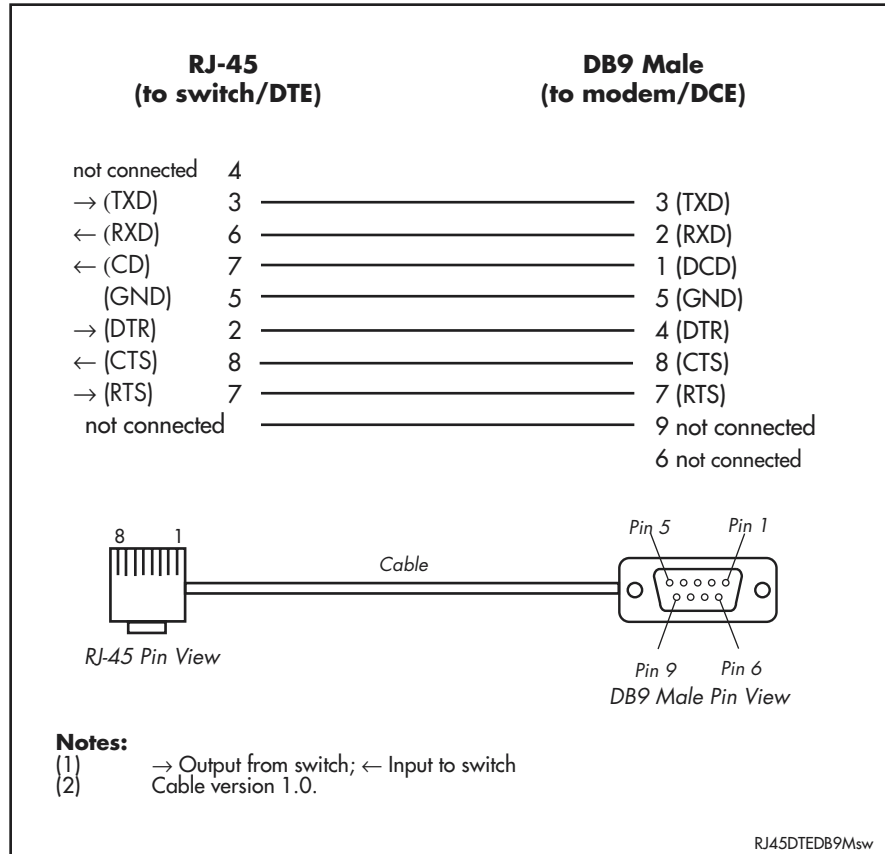

Figure 7: Pin wiring diagram for a DCE RS-232 Terminal Port (DB9 male connector) male to male modem cable.



More information on pin assignments for the RS-232 Terminal Port can be found in “RS-232 Terminal Port (ASYN0)” on page 15.

Cables for RJ-45 Ethernet LAN Interfaces

For 10BASE-T/100BASE-TX/1000BASE-T (10/100/1000BASE) connections, a twisted pair cable with four pairs and RJ-45 connectors must be used.

Table 6 on page 17 lists the cables used for network connections and testing of RJ-45 interfaces.



Caution. Do not plug a phone jack into any RJ-45 port. Doing so could damage the switch. Use only twisted pair cables with RJ-45 connectors.

Table 6: Cables for RJ-45 LAN interfaces.

Purpose	Interface type	Cable type	Pairs	Pin assignment
Network	10/100/1000BASE	Straight through	Four	Table 7 on page 18
Test	10/100/1000BASE	Crossover or straight through	Four	Table 8 on page 19 or Table 7 on page 18

Pin assignments

For twisted pair cables each pair is identified by two different colours. For example, one wire might be red, and the other red with a white stripe. An RJ-45 connector must be fitted to both ends of the cable. Figure 8 on page 18 illustrates the pin layout for RJ-45 connectors.

Figure 8: RJ-45 Pin layout.

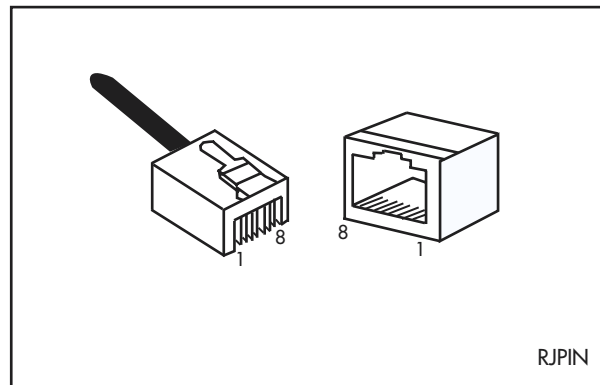

1000BASE straight through cable

For 1000BASE network connections, all four pairs are used and the cable is wired in a straight-through configuration. This cable can also be used, in conjunction with the software test facility, to test 1000BASE network ports. Table 7 on page 18 lists the pin assignments.

Table 7: Pin assignments, 10/100/1000BASE-T RJ-45 four pair straight-through cable.

End 1		End 2	
Pin	Pair	Pin	Pair
1	Pair 1+	1	Pair 1+
2	Pair 1-	2	Pair 1-
3	Pair 2+	3	Pair 2+
6	Pair 2-	6	Pair 2-
4	Pair 3+	4	Pair 3+
5	Pair 3-	5	Pair 3-
7	Pair 4+	7	Pair 4+
8	Pair 4-	8	Pair 4-

1000BASE crossover cable

For 1000BASE test cables, all four pairs are used and the cable is wired in either a crossover or straight-through configuration. Table 8 on page 19 lists the pin assignments for a crossover cable.

Table 8: Pin assignments, 10/100/1000BASE-T RJ-45 four pair crossover cable .

End 1		End 2	
Pin	Pair	Pin	Pair
1	Pair 1+	3	Pair 2+
2	Pair 1-	6	Pair 2-
3	Pair 2+	1	Pair 1+
6	Pair 2-	2	Pair 1-
4	Pair 3+	7	Pair 4+
5	Pair 3-	8	Pair 4-
7	Pair 4+	4	Pair 3+
8	Pair 4-	5	Pair 3-

Test Facility

This section introduces the Test Facility. The Test Facility is built into all AT-8800 Series software. For detailed information on operating the Test Facility, see the *Test Facility* chapter of the AT-8800 Series Software Reference.

Any interfaces being tested are dedicated to the Test Facility. The Test Facility can be thought of as a specialised interface module like PPP or Frame Relay.



Before using the test facility, disable any configurations (SET CONFIGURATION=NONE) and restart or reboot the switch.

Ethernet LAN Port Tests

A crossover cable is required to run an Ethernet LAN test. See “Useful Cables” on page 16 for details of how to make a suitable cable. To start the test, loop a four-pair crossover or straight-through cable between any two RJ-45 ports and enter:

```
ENABLE TEST INT=ALL
```



A loopback plug, instead of a crossover cable, can be used to test SC and MT-RJ GBIC interfaces.

All interfaces connected by crossover cables are tested. Test results are displayed with the command:

```
SHOW TEST
```

which produces a display like that shown in Figure 9 on page 20. A more detailed output (with frame counts) can be displayed with the command:

```
SHOW TEST COUNT
```

which is shown in Figure 10 on page 21.

Figure 9: Example output from the SHOW TEST command, with a test cable between ports 1 and 4.

Board	ID	Bay	Board Name	Rev	Serial number		
Base	157		AT-9812TF	P1-0	42029694		
Interface	State	Result	Type	Duration (minutes)	Details Data(%OK)		Control
port1	testing	wait 4 minutes	TP	< 1	GOOD (100.0)		-
port2	no test	-	-	-	-		-
port3	no test	-	-	-	-		-
port4	testing	wait 4 minutes	TP	< 1	GOOD (100.0)		-
port5	no test	-	-	-	-		-
port6	no test	-	-	-	-		-
port7	no test	-	-	-	-		-
port8	no test	-	-	-	-		-
port9	no test	-	-	-	-		-
port10	no test	-	-	-	-		-
port11	no test	-	-	-	-		-
port12	no test	-	-	-	-		-
port13	no test	-	-	-	-		-
port14	no test	-	-	-	-		-
port15	no test	-	-	-	-		-
port16	no test	-	-	-	-		-
asyn0	testing	wait 4 minutes	-	< 1	-		-

Figure 10: Example output for the SHOW TEST COUNT command, with a test cable between ports 1 and 4.

Board	ID	Bay	Board Name	Rev	Serial number		
Base	157		AT-9812TF	P1-0	42029694		
Interface	State	Type	Duration (minutes)	Tx	Frame Counters		
					RxTotal	RxGood	RxBad
port1	testing	TP	< 1	000298842	000298841	000298841	000000000
port2	no test	-	-	-	-	-	-
port3	no test	-	-	-	-	-	-
port4	testing	TP	< 1	000298842	000298841	000298841	000000000
port5	no test	-	-	-	-	-	-
port6	no test	-	-	-	-	-	-
port7	no test	-	-	-	-	-	-
port8	no test	-	-	-	-	-	-
port9	no test	-	-	-	-	-	-
port10	no test	-	-	-	-	-	-
port11	no test	-	-	-	-	-	-
port12	no test	-	-	-	-	-	-
port13	no test	-	-	-	-	-	-
port14	no test	-	-	-	-	-	-
port15	no test	-	-	-	-	-	-
port16	no test	-	-	-	-	-	-
asyn0	testing	-	< 1	000000000	000000000	000000000	000000000

Other Interface Tests

Refer to the *Test Facility* of the AT-8800 Series Software Reference for information on testing other interfaces.



If a test fails, please contact your Authorised Allied Telesyn distributor or reseller.

Redundant Power Supply (RPS)

RPS units enhance network reliability by providing backup coverage for switch Power Supply Units (PSUs).

AT-8800 Series switches have an RPS connector on their rear panel. The connector allows the switch to be used in conjunction with an RPS.

When an RPS is required, AT-8848 and AT-8824 models use the AT-RPS8000 system. RPS systems can be purchased separately.

AT-RPS8000

The AT-RPS8000 is a chassis that holds up to four removable AT-PWR8000 RPS units. To provide backup power to AT-8824 and AT-8848 switches, each switch must be connected to an AT-PWR8000 power unit, and the power unit must be installed in an AT-RPS8000 chassis.

Table 9 on page 22 lists the RPS connector's pin numbers and pin functions, as found on AT-8824 and AT-8848 switches.

Table 9: RPS Connector Pin Numbers and Functions.

Pin Number	Function
1	+12VDC
2	Remote Sense (RS) +5VDC
3	Remote Sense (RS) Ground
4	Remote Sense (RS) +3.3VDC
5	Redundant Power Supply (RPS) Present
6	Ground (+3.3VDC Return)
7	Ground (+5VDC Return)
8	+5VDC
9	Ground (+12VDC Return)
10	+3.3VDC
11	Ground (+3.3VDC Return)
12	+3.3VDC
13	Ground (+3.3VDC Return)
14	+3.3VDC
15	+5VDC
16	Ground (+5VDC Return)

Table 10 on page 22 illustrates the connector's pin layout, as found on the rear panel of AT-9812TF and AT-9816GF switches.

Table 10: AT-PWR8000 RPS Connector Pin Layout.

16	15	14	13	12	11	10	9
8	7	6	5	4	3	2	1

Pin 16 is at the connector's top left, while pin 1 is at its lower right.

Specifications

Dimensions

- Height = 67 mm (plus 5.5 mm if the rubber feet are used)

- Width = 440 mm (excluding rack-mounting brackets)
- Depth = 360 mm
- Weight = 6.76 kg with one AT-PWR9000 installed, 10.21 kg with four AT-PWR9000 power units installed

Mounting System

- 1.5U rack mounting

Environmental Conditions

- Operating temperature range: 0 to 40° C (32 to 104° F)
- Storage temperature range: -25 to 70° C (-13 to 158° F)
- Relative humidity range: 5 to 95% non-condensing

Regulatory Standards

- EMC: EN55022 Class A, FCC class A, and VCCI class A
- Immunity testing to EN55024, EN61000-3-2/3
- Safety: UL60950, CAN/CSA22.2, EN60950, No. 60950-00
- Certification: UL, cUL, TUV

LEDs

- AC supply to RPS
- RPS fan, PSU, and connection fault¹
- RPS is supplying power to switch¹

1. This LED is located on AT-9800 Series switches.

For LED descriptions, see “LEDs and What They Mean” on page 24.

Controls

- Individual power switch for each PWR bay
- Power switches recessed to prevent unintentional operation

AC Power Supply

- Universal 110/230 VAC 50/60 Hz input

DC Output

- +3.3VDC/16A
- +5VDC/16A
- +12VDC/0.5A

Port, Connector, and Cable Combinations

This section provides cabling guidelines for each switch model.

Table 11: Cable guidelines for AT-8800 Series switches.

Model	Port Type	Connector Type	Cable Type ¹	Maximum Cable Length
AT-8824 and AT-8848	10BASE-T/100BASE-TX	RJ-45	CAT5 CAT5E	120 m Max
AT-8824 and AT-8848	1000BASE-X	Varies with GBIC	Refer to GBICs user documentation	Refer to GBICs user documentation

1. Refer to the IEEE 802.3 standards for further cable information.

Troubleshooting

This section provides information on how to detect and resolve problems with AT-8800 Series switches and their expansion options.

Other sources of useful troubleshooting information are:

- www.alliedtelesyn.co.nz/support/at8800/
- The AT-8800 Series Software Reference.

LEDs and What They Mean

The following tables outline how LEDs on AT-8800 switches report faults and operational activities.

System LEDs

Table 12: System LEDs found on the AT-8800 Series Switch.

LED	State	Function
RPS (Redundant Power Supply)	Green	An RPS is connected to the switch and is supplying power.
FAULT	Red	The switch or management software is malfunctioning. PSU fail.
PWR (Power)	Green	The switch is receiving power from the AC power source.

Table 13: Port and GBIC LEDs on the AT-8800.

LED	State	Function
GBIC L/A (Link activity)	Green	A 1000 Mbps link is open. The link is operating in full duplex mode
	Flashing green	1000 Mbps full duplex activity is occurring
	Amber	A 1000 Mbps link is open. The link is operating in half duplex mode
	Flashing amber	1000 Mbps half duplex activity is occurring
GBIC	Green	A GBIC is installed and enabled
	Amber	A GBIC is installed but has not been recognised
	Flashing amber	A GBIC is installed and enabled, but a Tx fault is occurring
BASE-T L/A (Link activity)	Green	A 100 Mbps link is open
	Flashing green	100 Mbps activity is occurring
	Amber	A 10 Mbps link is open
	Flashing amber	10 Mbps activity is occurring
BASE-T D/C (Duplex/collision)	Green	The port is operating in full duplex mode
	Amber	The port is operating in half duplex mode
	Flashing amber	Collisions are occurring

Check these first

1. Check the power cord connections.
2. Check that the power supply voltage is stable.
3. Check that the correct data cables are being used and that their connections are secure.
4. Check that any GBICs are correctly installed and that they are compatible with the switch. Some switch models have limitations on the number of GBICs that can be installed. See “Gigabit Interface Converters (GBICs)” on page 27 for more information.
5. Make sure that other network devices are working properly.
6. Use the `SHOW INSTALL` command to check that the latest software release is loaded. See the *AT-8800 Series Software Reference* for more information about obtaining the latest software release.
7. If the switch is malfunctioning, reboot it by pressing the recessed Reset button or entering the command `RESTART REBOOT`. Alternatively, shut down and restart the switch using its power switch (AC models) or run/standby switch (DC models).

Some common problems and how to solve them

Link/Activity LED on any port is off

This can indicate:

- A loose data cable.
- The device at the other end of the connection is not working properly or is turned off.
- The data cable is not wired correctly.
- The network administrator has manually disabled the port through the software.
- The port's selected transmission mode does not match that of the attached device.

Perform the following steps in sequence:

1. Make sure the data cable connections are secure.
2. Make sure the device at the other end of the connection is switched on and working properly.
3. Check that the data cable is wired correctly.
4. If you can, log in and check the port status. See "To log In" on page 11 for more information on how to log in.
5. If the port is Enabled, make sure the transmission speed matches that of the connected device (auto-negotiating, full or half-duplex).



If the port is disabled, someone has used the software to manually disable it. You should find out why the port was disabled before enabling it.

Power LED is off

This can indicate:

- A loose power cord.
- A power supply failure.

Perform the following steps in sequence:

1. Check that the power cord connections are secure.
2. Check that all switches and circuit protection devices are in the ON position.
3. Ensure that the supply voltage is within the operational range (100/240 VAC 50/60 Hz for AC models).

Fault LED is on

This can indicate:

- There is a problem with the switch or PSU.
- The switch or management software is malfunctioning.
- A hardware fault is preventing switch start-up.

Perform the following steps in sequence:

1. Check “LEDs and What They Mean” on page 24 for descriptions and explanations of LED flashing sequences.
2. Reset the switch by pressing the recessed RESET button on the front panel.
3. If you were attempting to download software or manage the switch via the RS-232 Terminal Port, check that connections between the Terminal Port and local terminal or PC are secure.

If you cannot access the switch’s software because of a faulty RS-232 Terminal Port connection, you can still manage the switch via Telnet or SNMP until the problem is fixed.

4. Download the latest software release. See the *AT-8800 Series Software Reference* for more information on how to obtain the latest software release.

Expansion Options

This section provides an overview of the expansion options for AT8800 Series Switches. The following expansion options were available when this Reference was written. See your Authorised Allied Telesyn distributor or reseller, or visit www.alliedtelesyn.co.nz/support/at8800/ to see if any new options are available.

Gigabit Interface Converters (GBICs)

GBICs are removable gigabit port converters for switches that have GBIC bays. GBICs allow users to interchange port types to meet changing network requirements. GBICs can be purchased when a switch is purchased, or can be ordered separately as needed.

The following GBICs have been approved for use with AT-8800 Series switches:

- Allied Telesyn AT-G8SX 550m SX
- Allied Telesyn AT-G8LX10 10km LX
- Allied Telesyn AT-G8LX25 25km LX
- Allied Telesyn AT-G8LX40 40km LX
- Allied Telesyn AT-G8LX70 70km LX

For the latest list of approved GBICs, visit www.alliedtelesyn.co.nz/support/at8800/.

For information on installing GBICs, see the AT-8800 Series Quick Install Guide.

Any combination of copper and fibre GBICs can be installed in the AT-8800 Series switches.



A range of GBICs have been tested and approved for use with the AT-8800 Series, contact your authorised Allied Telesyn distributor or reseller for more information, or visit www.alliedtelesyn.co.nz/support/at8800/.



RX and TX terminal locations on SC fibre GBIC ports are the reverse of RX and TX terminal locations on fixed SC fibre ports. When looking at an SC fibre GBIC from the front, the RX terminal is on the left and the TX terminal is on the right.

GBIC 1000BASE-T Auto-Negotiation

1000BASE-T GBICs support only 1000 Mbps full duplex connections. Although 1000BASE-T GBICs will participate in auto-negotiation processes, they will only advertise 1000 Mbps. Half duplex, 10BASE-T, and 100BASE-TX modes are not supported.

While 1000BASE-T GBICs will auto-negotiate at the copper Ethernet level, the ports will behave as if in fixed 1000 Mbps full duplex mode. This is because the SERDES connection used by GBIC ports makes the auto-negotiation invisible to the switch, and so prevents a successful link negotiation.

When a 1000BASE-T GBIC is inserted into a GBIC slot, the port's auto-negotiation capability is disabled. This means that the port speed may not be set to "auto-negotiate". If the port had been configured to auto-negotiate (by default or by command) prior to the GBIC's insertion, then this configuration is overridden for as long as the GBIC remains in place.

Dual In-line Memory Modules (DIMMs)

Synchronous DRAM for AT-8800 Series switches is provided by a single DIMM. Three memory sizes are supported; 64 MBytes, 128 MBytes and 256 MBytes.



Only Allied Telesyn supplied DIMMs have been tested and approved for use with AT-8800 Series switches. Using DIMM that has not been approved may cause unreliable operation and will invalidate the switch's warranty.

To check how much DIMM is installed, enter

```
SHOW SYSTEM
```

For information on installing DIMM, see "Restricted Procedures" on page 28.

Restricted Procedures

This section contains procedures that should only be performed by authorised service personnel. Unauthorised use of procedures in this section may cause danger of injury from electric shock, damage to the switch, and invalidation of the product warranty.

If you would like to know more about the procedures outlined in this section, please contact your authorised Allied Telesyn distributor or reseller.

Installing DIMM

AT-8800 Series switches have one DIMM slot. The slot can be populated with a 64 MByte DIMM, a 128 MByte DIMM or a 256 MByte DIMM.



Only Allied Telesyn supplied DIMMs have been tested and approved for use with AT-8800 Series switches. Using DIMMs that have not been approved may cause unreliable operation and will invalidate the switch's warranty.



For AT-8800 Series switches, DIMMs should only be installed by authorised service personnel. Unauthorised opening of the switch's lid may cause danger of injury from electric shock, damage to the switch, and invalidation of the product warranty.

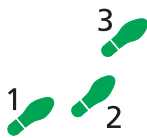

To install a DIMM in an AT-8800 series switch:

1. Avoid injury by working in a safe environment.

The workspace should be free of hazards, and there should be sufficient room to lay out the switch, DIMM, and tools.

2. Unpack the DIMM in an antistatic environment.



Do not attempt to install any hardware without observing correct antistatic procedures. Failure to do so may damage the switch or DIMM. If you are unsure what the correct procedures are, contact your authorised Allied Telesyn distributor or reseller.

3. If fitted, disconnect the switch's redundant power supply.

4. Disconnect the mains power cord.



Before removing the switch's lid, the power cord and, if connected, RPS power cord should be disconnected to reduce risk of electrical shock.

5. Remove all interface cables.

6. Remove the switch's lid.

The switch may need to be removed from any rack mounting system before its lid can be removed.

Using a Philips screwdriver, remove the 13 screws that secure the switch's lid. There are 5 screws located in countersunk holes on each side of the lid, and 3 screws at the rear. Slide the lid towards the rear of the switch to remove.

7. Prepare the DIMMs.

In an antistatic environment, remove the DIMM from its packing material. Be sure to observe ESD precautions.



Do not attempt to install DIMM without observing correct antistatic procedures. Failure to do so may damage the DIMM and switch. If you are unsure what the correct procedures are, contact your authorised Allied Telesyn distributor or reseller.

8. To remove an existing DIMM.



Before removing the switch's lid, the power cord and, if connected, RPS power cord should be disconnected to reduce risk of electrical shock.

The DIMM is held in place by two retaining latches, one latch at each end of the DIMM slot. Release these latches and carefully pull the DIMM from the DIMM slot.

9. Align and insert the first DIMM.

Holding a DIMM at an angle of about 30 degrees from horizontal, align the notches on its connector strips with the notches on the empty DIMM slot.

Insert the DIMM into the DIMM slot, sliding it along the two DIMM guides and press firmly until both the retaining latches automatically click into place. The latches should hold the DIMM in place.

Testing DIMM

The switch is unlikely to boot unless the DIMM is correctly installed. If the switch does boot but you suspect the DIMM is malfunctioning, enter the command:

```
SHOW SYSTEM
```

to display the system information shown in Figure 11 on page 31. In the output's memory section there should be an entry showing the size of DRAM. If the DRAM size is less than the size of DIMM that has been installed, then the switch has not correctly detected the DIMM. The most likely cause is that the DIMM connector is not plugged into its slot correctly. Repeat the installation process, paying particular attention to the DIMM insertion step.

After repeating the installation, use the SHOW SYSTEM command again, and if the display is still not correct, contact your authorised Allied Telesyn distributor or reseller.



If you have any difficulty with the DIMM at any time, contact your authorised Allied Telesyn distributor or reseller and quote the serial numbers of both the base card on the switch and the DIMM. The switch's serial numbers and revision details can be read using the SHOW SYSTEM command. It's a good idea to record this information for later reference.

Figure 11: Example output from the SHOW SYSTEM command for an AT-8800 Series switch, showing DRAM.

```

Switch System Status                               Time 11:25:50 Date 28-Mar-2002.
Board      ID  Bay Board Name                       Rev      Serial number
-----
Base       156   AT-9816GF                                       M1-1    46709354
-----
Memory -   DRAM : 65536 kB   FLASH : 15360 kB
-----
SysDescription
Allied Telesyn AT-9816GF version 2.4.0-00 22-Aug-2001
SysContact

SysLocation

SysName

SysDistName

SysUpTime
3382 ( 00:00:33 )
Software Version: 2.4.0-00 22-Aug-2001
Release Version : 2.4.0-00 22-Aug-2001
Release built   : Mar 28 2002 at 00:20:31
Patch Installed : NONE
Territory      : usa
Help File      : help.hlp

Main PSU       : On           Main Fan       : On
RPS Monitor    : Off
Current Temperature : 29 Celsius

Configuration
Boot configuration file: Lucy.cfg (exists)
Current configuration: snoopy.cfg

Security Mode  : Disabled

Warning (2048283): No patches found.

```

Diagnostics

The switch software includes a set of diagnostic programs. These programs perform basic level checks of all system components. They do not run in conjunction with the normal operating code, and require that the system be totally dedicated to their use. A detailed knowledge of the way the switch hardware functions is necessary if diagnostics are to be used effectively.



The switch will not perform switching operations if diagnostics are running.



This section is not intended as a guide to the diagnostics software. Diagnostics are designed to be run by service personnel only. For more information, contact your Authorised Allied Telesyn distributor or reseller.

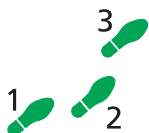

To enable diagnostics mode:

1. Connect a terminal to the RS-232 Terminal Port (ASYN0).

Using a terminal cable, connect a terminal to the RS-232 Port (ASYN0) on the switch. See “Useful Cables” on page 16 for more information on terminal cables.

Set the terminal communication parameters to the following:

- Baud rate: 9600
- Data bits: 8
- Parity: None
- Stop bits: 1
- Flow control: Hardware

2. Restart the switch.

Restart the switch, either by using a pen or pencil to operate the recessed reset button on the switch’s front panel, or by using the terminal to log in and enter the command:

```
RESTART REBOOT
```

See “To log In” on page 11 for more information on how to log in.

3. Enable diagnostics mode during start-up.

During the switch start-up process, at the prompt:

```
Force EPROM download (Y)?
```

press [Ctrl/D] on the terminal to enter diagnostics mode. A banner page will be displayed on the terminal (Figure 12 on page 32). This can be used to check that the terminal is correctly connected.



Performing a Full Flash Test or erasing flash will delete all configuration and release files. Make sure you know how to reload these files before erasing flash or performing a flash test.

Figure 12: AT-9800 Series diagnostics banner page.

```
* * * Diagnostic Mode * * *

version 16-Mar-98

Main Menu:
  0. Restart
  1. Full RAM test
  2. ROM checksum test
  3. Full FLASH test
  4. Totally Erase FLASH
  5. Battery backed RAM test
Enter selection ==>
```

To run a diagnostic program, enter the corresponding letter or number (or key). There are several sub-menus to cover all the available options. Table 14 on page 33 lists the control keys for diagnostic operations.

Table 14: Basic commands for running the diagnostics.

Key	Function
Q	Quits any running tests and displays the banner page.
S	Prints a summary of test results so far.

A reasonable understanding of the system's structure is needed to operate diagnostics and interpret the results.

To restore the switch to normal operation, use a pen or pencil to operate the recessed reset button on the front panel, or press "0" (zero) to restart.

Contacting Us

With locations covering all of the established markets in North America, Latin America and Europe, Allied Telesyn provides localized sales and technical support worldwide. To find our representative nearest you, visit Allied Telesyn on the web at: <http://www.alliedtelesyn.com>.