

AT-A45/xx Series, AT-A46, and AT-A47 Expansion Modules

Installation Guide

Allied Telesyn, Inc.
960 Stewart Drive, Suite B
Sunnyvale, CA 94085 USA
Tel 1 (408) 730-0950 • Fax 1 (408) 736-0100
Visit our web site at: www.alliedtelesyn.com

Overview

These expansion modules provide optional uplink ports for the AT-8000 Series Fast Ethernet Switches. They are designed for the two expansion slots on the front of the switches. The expansion modules, which can be installed in any combination and without having to power OFF the switch, offer flexibility in building or expanding your network. A maximum of two expansion modules can be installed in a switch.

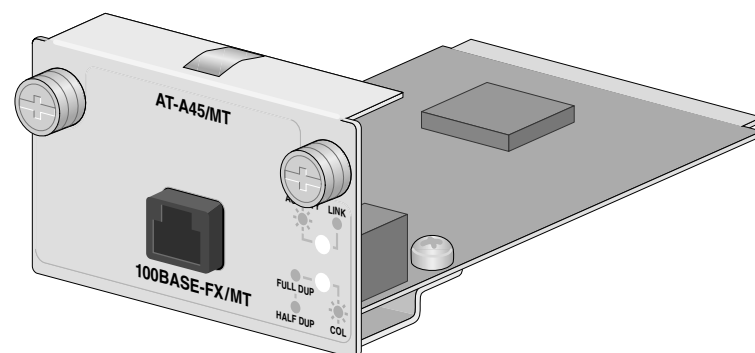

Note

Expansion modules are supported on the AT-8000 Series Fast Ethernet Switches.

Expansion Modules Available

The following expansion modules are available for your AT-8000 Series Fast Ethernet Switch.

Expansion Module	Port Type	Connect or Type	Cable Type	Maximum Cable Length
AT-A45/MT	100Base-FX	MT-RJ	50/125 or 62.5/125 micron multimode fiber	Half-duplex: 412 m (1,360 ft) Full-duplex: 2 km (6,600 ft)
AT-A45/SC	100Base-FX	SC	50/125 or 62.5/125 micron multimode fiber	Half-duplex: 412 m (1,360 ft) Full-duplex: 2 km (6,600 ft)
AT-A45/SC-SM15	100Base-FX	SC	9/125 micron single-mode fiber	15 km (9.3 mi)
AT-A46	10/100/ 1000Base-T ¹	RJ-45	10Base-T: Category 3 or better 100/1000Base-T: Category 5 or better	100 m (328 ft)
AT-A47	1000Base-X	Varies by GBIC module ²	Varies by GBIC module ²	Varies by GBIC module ²

1. The default configuration setting for the port on this module is Auto-MDI when operating at 10 or 100 Mbps. The port uses two pair of twisted pair cable when operating at 10 or 100 Mbps and four pair when operating at 1000 Mbps.
2. Refer to the GBIC Module Installation Guide or contact your Allied Telesyn sales representative for additional information on available GBIC modules.

Note

The GBIC module for the AT-A47 expansion module is sold separately.

Related Documents

The Allied Telesyn web site at www.alliedtelesyn.com offers you an easy way to access the most recent documentation, software, and technical information for all of our products. For details on the features and functions of your Allied Telesyn AT-8000 Series Fast Ethernet Switch, refer to the following manuals from our web site:

- AT-8000 Series Fast Ethernet Switch Installation Guide**
PN 613-50244-00
- AT-S39 Management Software User's Guide**
PN 613-50245-00

Package Contents

Make sure the following items are included in the shipping package. If any item is missing or damaged, contact your Allied Telesyn sales representative for assistance.

- One Allied Telesyn Expansion Module
- Installation Guide
- Warranty Card

Installing an Expansion Module

Caution

Before installing an expansion module, refer to Appendix C in the "AT-8000 Series Fast Ethernet Switch Installation Guide" for electrical safety and emission information.

This section describes how to install an optional expansion module. To install an expansion module, follow these steps:

1. Unpack the module from its shipping container and store the packaging material in a safe location.

Note

You must use the original shipping material if you need to return the module to Allied Telesyn.

2. Check that the module package includes all the items listed in section Package Contents. If any item is missing or damaged, contact your Allied Telesyn sales representative for assistance.
3. Select a switch where you will install the expansion module.
4. Face the front panel of the switch and locate the expansion slots (left side of switch).
5. To remove an expansion slot faceplate, using a Phillips screwdriver, carefully loosen the installation screws found on the left and right sides of the faceplate, as displayed below. An expansion module can be installed in either expansion slot.

Caution

Be sure to observe all standard electrostatic discharge (ESD) precautions, such as wearing an antistatic wrist strap, to avoid damaging the device. If removing an expansion module, store the module in an antistatic bag or immediately install it in another switch. An expansion module can be damaged by static electricity.

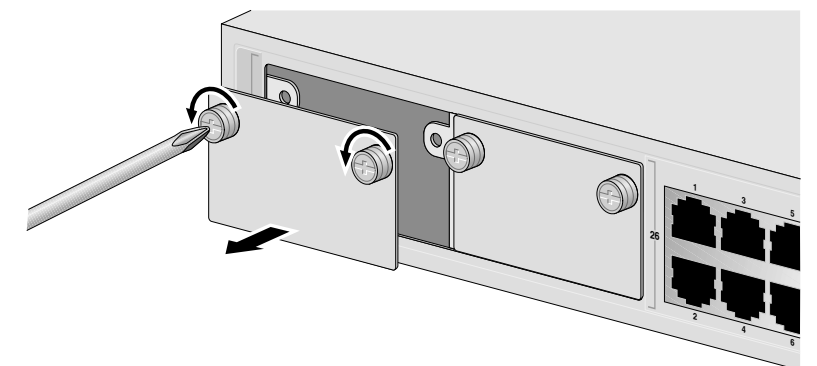

6. Remove the faceplate from the slot.
Keep the faceplate in a safe area in case you need to replace it on the slot again. The faceplate will keep any dust from getting into the switch and will maintain proper air-flow if the slot remains empty.

7. Carefully slide the expansion module into the slot until the expansion module faceplate makes contact with the switch, as displayed below. Avoid touching the expansion module components.

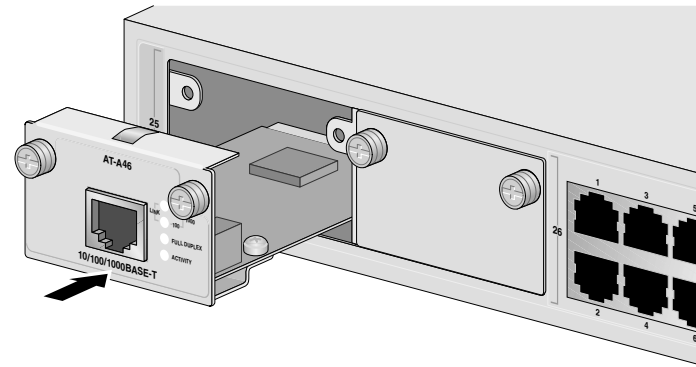

8. Secure the expansion module to the switch by using a Phillips screwdriver to tighten the installation screws found on the expansion module faceplate.

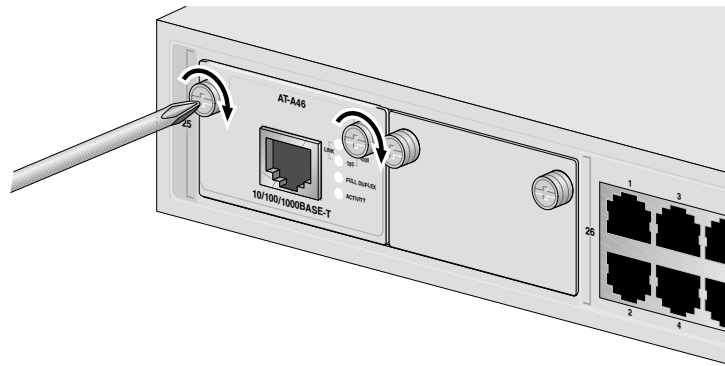

Note

Always use the installation screws to secure the expansion module to the switch. Leaving an expansion module partially seated may cause the system to halt and subsequently crash.

9. If you purchased an AT-A47 expansion module, slide the GBIC module into the slot on the expansion module until it snaps into place, as displayed below.

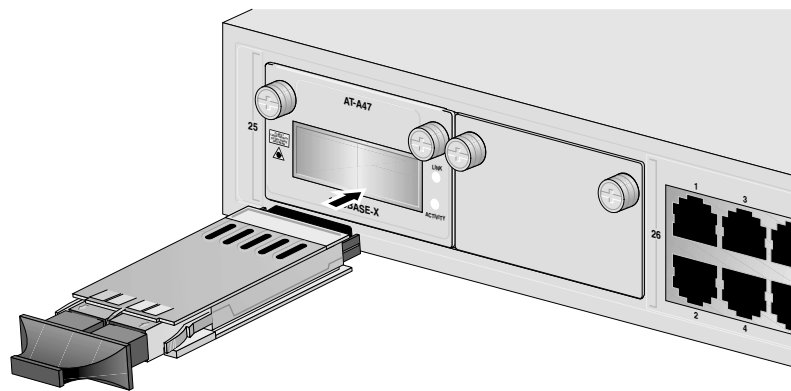

10. Connect the twisted pair or fiber optic data cable to the expansion module.

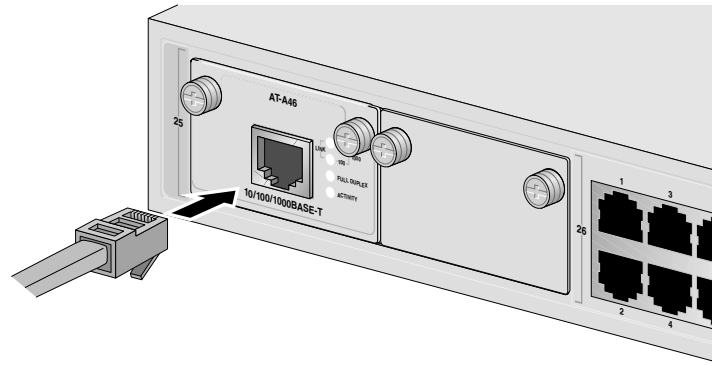

11. Make sure the LINK LED on the front of the expansion module is steady green. (A 1000Base port may require from five to ten seconds to initially establish a link with an end node.)

LEDs

The expansion modules have port LEDs which display link and activity status on the port. Refer to the table below for port LED information.

LED	State	Description
AT-A45/xx Series Expansion Modules		
LINK	Steady Green	The port has established a valid link with the end node.
	Flashing Green	The port is transmitting and/or receiving data.
DUPLEX	Steady Green	The port is operating in full-duplex.
	Steady Amber	The port is operating in half-duplex.
	Flashing Amber	Collisions are occurring on the port.
AT-A46 Expansion Module		
LINK 10	Steady Green	The port has established a valid 10 Mbps link with the end node.
LINK 100	Steady Green	The port has established a valid 100 Mbps link with the end node.
Both LINK 10 and LINK 100	Steady Green	The port has established a valid 1000 Mbps link with the end node.
FULL DUPLEX	Steady Green	The port is operating in full-duplex.
	OFF	The port is operating in half-duplex.
ACTIVITY	Flashing Green	The port is transmitting and/or receiving data.
AT-A47 Expansion Module		
LINK	Steady Green	The port has established a valid 1000 Mbps link with the end node.
ACTIVITY	Flashing Green	The port is transmitting and/or receiving data.

Port Specifications

The table below provides port specifications for the AT-A45/MT and AT-A45/SC expansion modules.

Pin	Signal
Operating Wavelength	1310 nm
Transmitter Output Power	50/125 μ m cabling Min: -22.5 dBm avg. Max: -14 dBm avg. 62.5/125 μ m cabling Min: -19 dBm avg. Max: -14 dBm avg.
Receiver Sensitivity	Max: -14 dBm avg.

Technical Specifications

Maximum Operating Temperature:	0° C to 40° C (32° F to 104° F)
Maximum Storage Temperature:	-20° C to 80° C (-4° F to 176° F)
Operating and Storage Altitude:	Up to 3,048 meters (10,000 feet)
Relative Humidity Operating and Storage:	5% to 80% (non-condensing)
EMC:	FCC Class A, EN55022 Class A, EN55024
Safety:	EN60825, EN60950, UL1950 (UL/cUL)

Electrical Safety and Emission Statement

Standards: This product meets the following standards.

U.S. Federal Communications Commission	
RADIATED ENERGY Note: This equipment has been tested and found to comply with the limits for a Class A digital device pursuant to Part 15 of FCC Rules. These limits are designed to provide reasonable protection against harmful interference when the equipment is operated in a commercial environment. This equipment generates, uses, and can radiate radio frequency energy and, if not installed and used in accordance with this instruction manual, may cause harmful interference to radio communications. Operation of this equipment in a residential area is likely to cause harmful interference in which case the user will be required to correct the interference at his own expense.	
Note: Modifications or changes not expressly approved of by the manufacturer or the FCC, can void your right to operate this equipment.	
Industry Canada	
This Class A digital apparatus meets all requirements of the Canadian Interference-Causing Equipment Regulations. Cet appareil numérique de la classe A respecte toutes les exigences du Règlement sur le matériel brouilleur du Canada.	

Emission	FCC Class A, EN55022 Class A, VCCI Class A
WARNING:	In a domestic environment this product may cause radio interference in which case the user may be required to take adequate measures.
	
Immunity	EN50082-1
Electrical Safety	UL1950 (UL/cUL), EN60950 (TUV)