

AR400 Series Router Hardware Reference



AR440S
AR441S
AR450S

AR400 Series Router Hardware Reference
Document Number C613-03086-00 REV C

© 1999-2005 Allied Telesyn Inc. All rights reserved. No part of this publication may be reproduced without prior written permission from Allied Telesyn Inc.

Allied Telesyn Inc. reserves the right to change specifications and other information in this document without prior written notice. The information provided herein is subject to change without notice. In no event shall Allied Telesyn Inc. be liable for any incidental, special, indirect, or consequential damages whatsoever, including but not limited to lost profits, arising out of or related to this manual or the information contained herein, even if Allied Telesyn Inc. has been advised of, known, or should have known, the possibility of such damages.

All company names, logos, and product designs that are trademarks or registered trademarks are the property of their respective owners.

Contents

Introduction	4
Models Covered By This Reference	4
Where To Find More Information	4
AR440S and AR441S ADSL Routers	5
AR450S Router	8
Online Documentation	10
AT-TFTP Server	11
Using Windows Terminal and HyperTerminal	12
Router Start-Up	15
Flash Memory	19
Asynchronous Interfaces	21
Port Interface Cards (PICs)	21
RS-232 Terminal and Modem Cables	22
Test Facility	24
Loopback Plugs	26
Restricted Procedures	27
Diagnostics	27
Lithium Battery Replacement	28
Contacting Us	28

Introduction

The AR400 Series routers are high-performance broadband routers based around 10BASE-T/100BASE-TX switch ports. The AR440S and AR441S routers include an ADSL port, and a Port Interface Card (PIC) bay. The PIC bay adds expansion flexibility by allowing you to install a PIC card, available with ISDN (PRI E1/T1, BRI S/T, or BRI U), Ethernet, synchronous, or asynchronous ports. The AR450S has dedicated WAN and DMZ eth ports, and two asynchronous ports.

This Hardware Reference describes the hardware features of AR400 Series router models. Hardware and installation information for Port Interface Cards (PICs) can be found in the *Port Interface Card Quick Install Guide* and *Port Interface Card Hardware Reference*. This Hardware Reference does not cover software configuration or software installation procedures. For information on software, refer to the *AR400 Series Router Software Reference*.

Models Covered By This Reference

This Hardware Reference includes information on the following models:

- AR440S
- AR441S
- AR450S

Hardware Reference updates can be found at www.alliedtelesyn.com/support/software/.

Where To Find More Information

The Documentation and Tools CD-ROM bundled with each router contains the complete document set for your router and, where applicable, its expansion options. The CD-ROM also includes tools for managing your router.

The Document Set includes:

- the *Quick Install Guide* for your router, which provides safety and statutory information, and outlines how to install the router
- this *AR400 Series Router Hardware Reference*, which provides detailed information on the hardware features of AR400 Series routers
- the *AR400 Series Software Reference*, which provides detailed information on configuring the router and its software
- the *Port Interface Card Quick Install Guide*, which outlines the procedure for installing PICs
- the *Port Interface Card Hardware Reference*, which provides detailed information on PICs

These documents can also be downloaded from the Support Site at www.alliedtelesyn.com/support/software/.

AR440S and AR441S ADSL Routers

Each AR440S or AR441S router provides:

- AR440S: One Asynchronous Digital Subscriber Line (ADSL) Annex A port
- AR441S: One Asynchronous Digital Subscriber Line (ADSL) Annex B port
- Five 10/100 Mbps full duplex, Layer 2 switched Ethernet LAN ports.

All LAN ports have Auto-MDI, however if Auto-MDI is turned off, then all ports are hardwired as MDI-X. Software can also force a port to either MDI or MDI-X.

- One asynchronous port (ASYN0)

The RS-232 (V.24) asynchronous serial port (ASYN0) has a DB9 male connector, is wired as a DTE port and can be used as a general purpose port for terminals, printers or modems. For pin wiring and default communication settings, see [“Asynchronous Interfaces” on page 21](#).

- One PIC bay

Front and rear panels of the AT-AR440S router are shown in the following figure. The AR441S front and rear panels look the same, except for the name on the front panel.

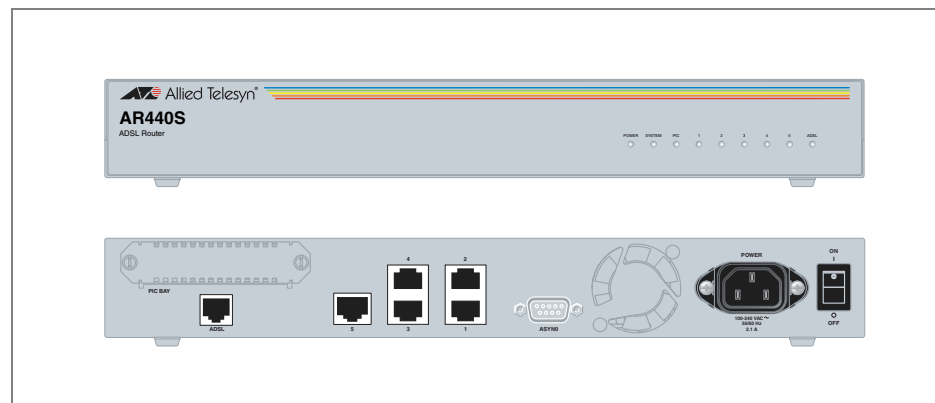

- Specifications**
- 300 MHz RISC processor
 - 64 MBytes of SDRAM
 - 16 MBytes of flash memory (1 MByte reserved for boot block code)
 - 802.1Q tagged VLAN support
 - Universal AC power supply
 - On-board hardware encryption processor for DES, 3DES and AES.
Some encryption options may require feature licenses.

ADSL interfaces The ADSL port has an RJ-11 connector, and supports Dying Gasp. The speed depends on the DSLAM to which the router is connected, and the length and interference on the cable connecting them. The following table shows the pin wiring for the ADSL interface.

Pin*	Function
1	<i>Not connected</i>
2	<i>Not connected</i>
3	ADSL+
4	ADSL-
5	<i>Not connected</i>
6	<i>Not connected</i>

*Pins are numbered from left to right.

Port Interface Card bay

The PIC bay can accommodate any of the following PICs:

- AT-AR020 PRI E1/T1 PIC, one Primary Rate E1/T1 port.
- AT-AR021(S) BRI-S/T PIC, one Basic Rate ISDN S/T port.
- AT-AR021(U) BRI-U PIC, one Basic Rate ISDN U port.
- AT-AR022 ETH PIC, one Ethernet LAN AUI/10BASE-T port.
- AT-AR023 SYN PIC, one Synchronous port with universal 50-way AMPLIMITE connector.
- When installed in an AR440S or AR441S router and operating in V.35 mode, synchronous PICs have full V.35 functionality, but their output voltages may not be within the voltage range set by the V.35 specification.
- Synchronous PICs installed in an AR440S or AR441S cannot be fully tested with Syntester.
- AT-AR024 ASYN4 PIC, four Asynchronous ports with RJ-45 connectors.
- AT-AR026 4ETH PIC, four 10BASE-T/100 BASE-TX auto-negotiating ports with RJ-45 connectors.
- AT-AR027 VoIP-FXS PIC, two Foreign Exchange Subscriber (FXS) ports with RJ-11 connectors.

Environmental conditions

- Operating temperature range: 0 to 50° C (32° to 122° F)
- Storage temperature range: -25 to 70° C (-13° to 158° F)
- Relative humidity range - Storage: 5 to 95% non-condensing
- Relative humidity range - Operating: 5 to 80% non-condensing
- Operational altitude: 3,000 metres maximum (10,000 feet)

Power supply

The routers have a universal AC input connector and a power switch on their rear panel. The routers require a power input of 100-240 VAC and 50–60Hz.



Caution Some interfaces that may be installed in the router are not transformer isolated. This means they will be referenced to the frame ground of the equipment and may be damaged if connected to an interface on another piece of equipment which is at a different ground potential.

AR440S, AR441S LEDs

The following table shows functions of the AR440S and AR441S router LEDs.

LED	State	Function
Power	Green	The router is receiving power and the power switch is ON.
System	Red	Lit briefly during router start up, or the router is malfunctioning.
	Red flashing	The fan has failed.
	Off	Normal operation.
PIC	Green	A port interface card (PIC) is correctly installed and has been detected by the router.
	Off	No PIC is installed, or the router has not recognised the PIC.
1 - 5	Green	A 100 Mbps link has been established through the corresponding switch port.
	Green flashing	Data is being transmitted through the corresponding switch port at 100 Mbps.
	Amber	A 10 Mbps link has been established through the corresponding switch port.
	Amber flashing	Data is being transmitted through the corresponding switch port at 10 Mbps.
	Off	No link is present through the corresponding port.
ADSL	Green	A link has been established through the ADSL port. It is ready to send or receive data.
	Green flashing fast	Data is being transmitted or received through the ADSL port.
	Green flashing slow (1 sec)	The ADSL port is in Loopback mode.
	Amber	The ADSL DSP is initialised and the port handshakes (looking for tones) or is physically disconnected.
	Amber flashing	The ADSL port has found tones, and is training to negotiate the link.
	Green and amber alternating	There is a fault in the ADSL port.
	Off	The ADSL port is disabled, or the ADSL DSP is initialising

AR450S Router

Each AR450S provides:

- Five 10/100 Mbps full duplex, Layer 2 switched Ethernet LAN ports.

All LAN ports have Auto-MDI, however if Auto-MDI is turned off, then all ports are hard-wired as MDI-X. Software can also force a port to either MDI or MDI-X.

- Two 10/100 Mbps full-duplex Eth WAN ports
- Two asynchronous ports (ASYN0 and ASYN1)

The RS-232 (V.24) asynchronous serial ports (ASYN0, ASYN1) has a DB9 male connector, is wired as a DTE port and can be used as a general purpose port for terminals, printers or modems. For pin wiring and default communication settings, see [“Asynchronous Interfaces” on page 21](#).

The following figure shows the front and rear panels of the AT-AR450S router.

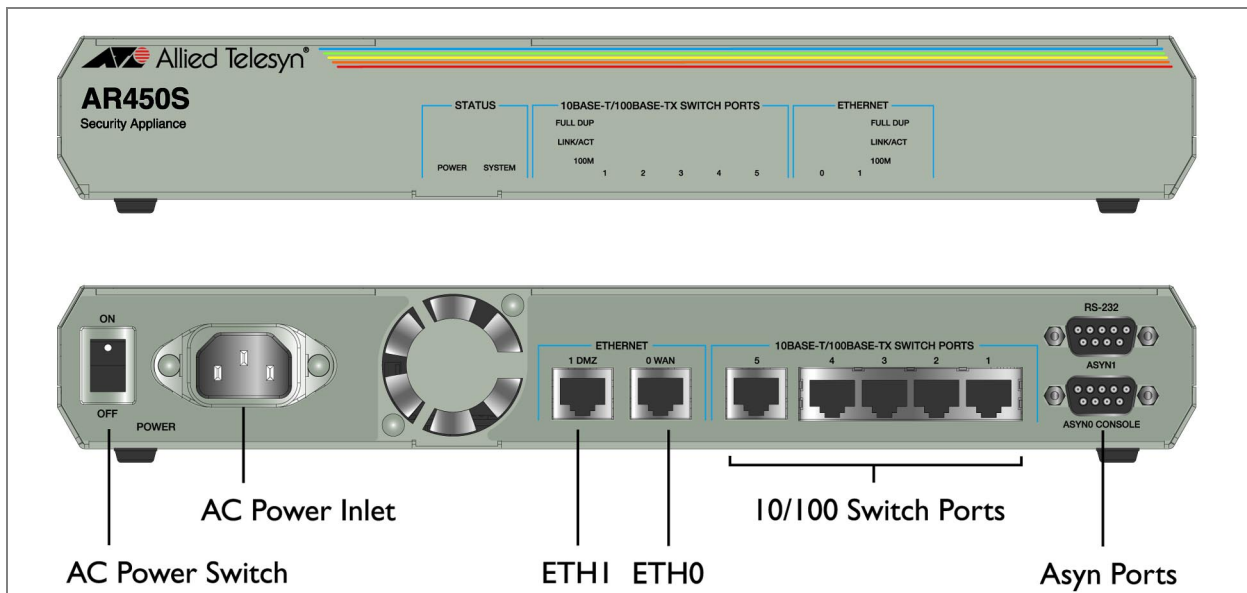

Specifications

- 400 MHz RISC processor
- 64 MBytes of SDRAM, expandable to 256 MBytes
- 16 MBytes of flash memory (1 MByte reserved for boot code)
- On-board hardware encryption processor
- 802.1Q tagged VLAN support
- Universal AC power supply

Random Access Memory (RAM)

The AR450S has 64MB of SDRAM provided on a single DIMM. 128MB and 256MB ECC SDRAM are also supported. See your authorised Allied Telesyn distributor or reseller for upgrade options. Other supplier's DIMMs are not approved, and therefore not supported, but may function correctly.

The amount of DRAM present in a router can be checked using the command:

```
show system
```

The *DRAM* and *FLASH* fields show the amounts of DRAM and flash memory, respectively.

Encryption processor Some encryption options require feature licences. The on-board encryption processor has the following features:

- single and triple DES, and AES symmetric encryption algorithms
- SHA-1 and MD-5 hashing support
- RSA and DH public key support.

- Environmental conditions**
- Operating temperature range: 0 to 40° C (32° to 104° F)
 - Storage temperature range: -25 to 70° C (-13° to 158° F)
 - Relative humidity range—storage: 5 to 95% non-condensing
 - Relative humidity range—operating: 5 to 80% non-condensing
 - Operational altitude: 3,000 metres maximum (10,000 feet)

Power supply The router has a universal AC input connector and a power switch on its rear panel. The router requires a power input of 100-240 VAC and 50–60Hz.

AR450S LEDs The following table shows functions of the AR450S LEDs.

LED	State	Function
Power	Green	The router is receiving power and the power switch is in the ON position
System	Amber	Lit briefly during router start up, or the router is malfunctioning.
	Amber flashing	The router fan has failed.
	Off	Normal operation
Full	Green	The corresponding port is operating at full-duplex
	Off	The corresponding port is operating at half-duplex
Link/ACT	Green	A link has been established through the corresponding port
	Flashing	Data is being transmitted through the corresponding port
	Off	No link is present through the corresponding port
100M	Green	The corresponding port is operating at 100Mbps
	Off	The corresponding port is operating at 10Mbps

Online Documentation

This section provides a step-by-step guide to accessing documentation on the CD-ROM. Adobe Acrobat Reader must be installed to view the documentation.

To use the CD-ROM, follow these steps

1. Insert your router's Documentation and Tools CD-ROM in the CD-ROM drive.

2. If the Welcome screen does not appear.

Select "Run" from the Start Menu (Windows 98, 2000 or XP).

Type d:\start.exe (where d: is the CD-ROM drive letter) and click OK.

3. To view a document.

Click on the document title.

4. To navigate around PDF documents.

Use the toolbar buttons, keyboard shortcuts, or commands from the Document menu to page through the document.

Click on a bookmark, thumbnail or hypertext link to jump to a specific section or topic.

Use the Search command to search for keywords or phrases.

For more information about using the Adobe Acrobat Reader, select "Reader Guide" from the Help menu.

5. To install any of the tools included on the CD-ROM.

Click on a link in the Welcome screen.

AT-TFTP Server

This section provides information on how to access and use AT-TFTP Server. AT-TFTP Server can be used to transfer configuration files as well as to download software patches and releases.

To use AT-TFTP Server

1. If AT-TFTP Server has not yet been installed.

Install it now from the router's Documentation and Tools CD-ROM.

To install AT-TFTP server, choose AT-TFTP Server from the Start > Programs > Allied Telesyn > AT-TFTP Server menu.

2. To set preferences for the AT-TFTP Server.

Select "Options" from the File menu to display the "Set Preferences" dialog box.

The "Default file transfer directory" field specifies the directory that AT-TFTP Server will read from or write to for file requests that do not include a directory specification.

To prevent unauthorised access to private directories, enter a path name in the "Restrict to directory" field. AT-TFTP Server will use only the specified directory, even if file requests contain references to other directories.

Select "Read only" to prevent files being written to the PC. To use the PC to archive router scripts created using the router's **create config** command, select "Read Write".

Make necessary changes and click "OK".

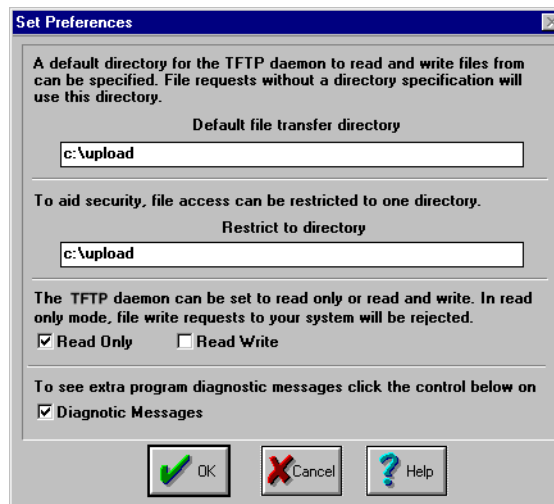

3. To load a file from AT-TFTP Server to the router.

On a terminal connected to the router, type the command:

```
load method=tftp file=filename server=ipadd dest=flash
```

where *filename* is the name of the file to download and *ipadd* is the IP address of the PC running AT-TFTP Server.

4. To save a TFTP Server log.

Select "Save As" from the File menu.

TFTP requests are logged to the AT-TFTP Server main window.

Using Windows Terminal and HyperTerminal

You can use a PC running terminal emulation software as the manager console, instead of a terminal. There are many terminal emulation applications available for PCs, but the most readily available are the Terminal and HyperTerminal applications included in Microsoft Windows 98, 2000, and XP Professional. In standard Windows installations, HyperTerminal is available from the Communications submenu.

The key to successful use of terminal emulation software with the router is to configure the software and router with matching communications parameters. The following procedure can be applied to most terminal emulation programs. Dialog boxes in the procedure are from Windows 2000 and XP Professional.

To configure Windows HyperTerminal for 2000 and XP Professional

1. Start the program in Windows by doing one of the following:
 - Select Programs > Accessories > Communications > HyperTerminal.
 - Double-click the Hypertrm.exe icon.
2. In the Connection Description dialog box:
 - Enter a name for the connection, such as Admin.
 - Select an icon from the scrollable list and click the OK button.



3. In the “Connect using” field on the Connect To dialog box, select the COM port on the PC used to connect to the router. and click the OK button.



4. In the COM n Properties dialog box, set port parameters as follows, and click the OK button.

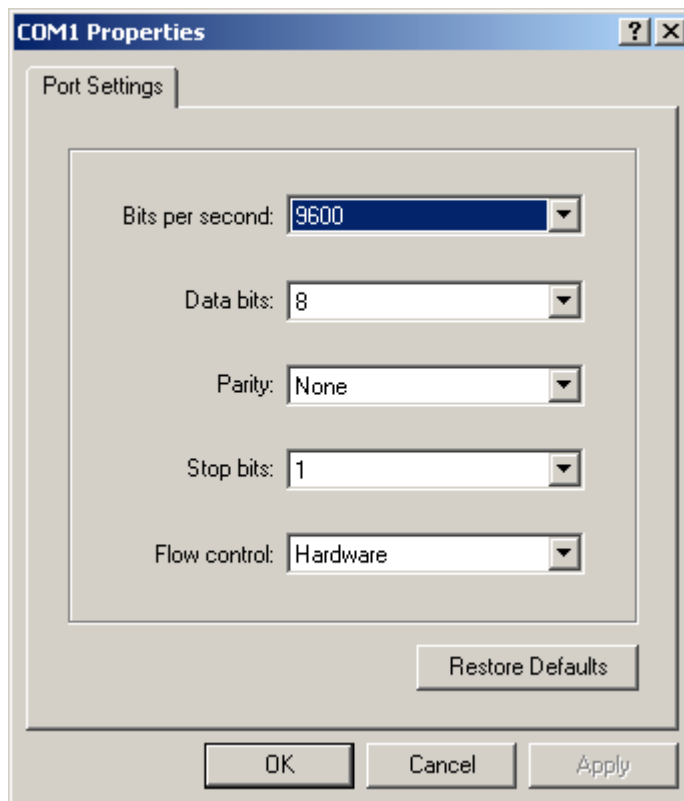

5. From the main HyperTerminal window, select Properties from the File menu. Click the Settings tab, and set the Properties dialog box as follows.

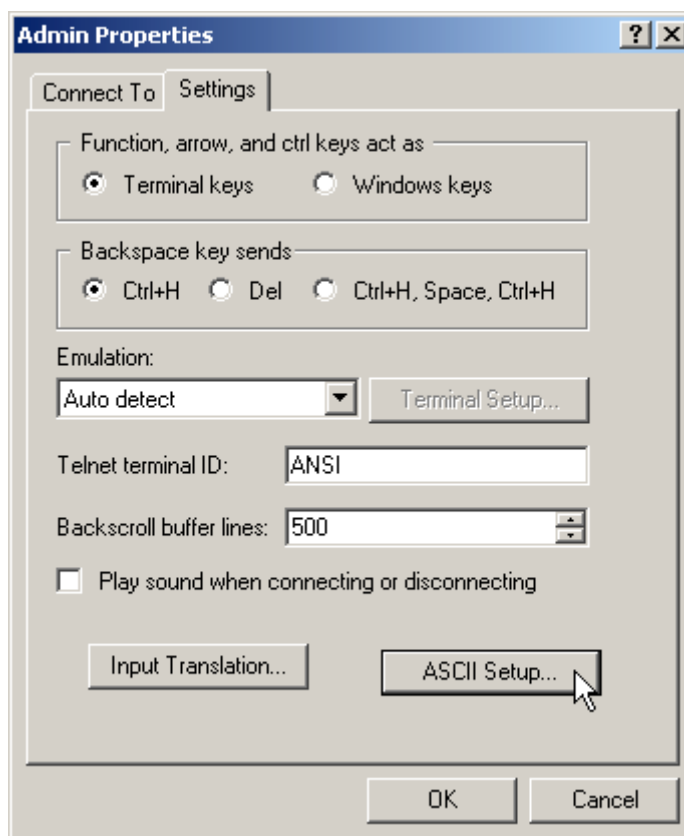

6. Click ASCII Setup to display the ASCII Setup dialog box, and ensure the following options are **not** selected:
- Echo typed characters locally
 - Append line feeds to incoming line ends

Set other parameters as necessary and click the OK buttons on both dialog boxes to close them.

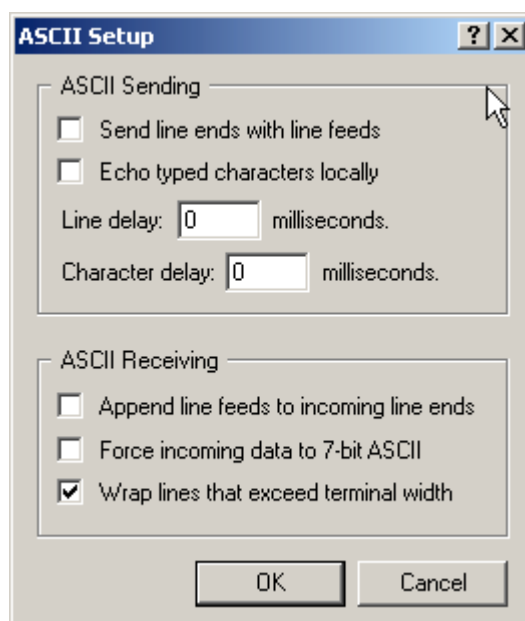

7. Save the current session by selecting Save from the File menu on the main HyperTerminal window. This creates a connection icon with the name you assigned in the HyperTerminal group.

To use the configuration, double-click the connection icon. When the HyperTerminal window appears, press the Enter key several times; the router's login prompt is then displayed.

Router Start-Up

At start-up, the manager can choose to run either the software release stored in the flash boot block, or the software release specified by the INSTALL parameters previously set using the **set install** command.

All code is executed out of system RAM. At power-up the boot code is loaded from the flash boot block to RAM. The boot code checks the INSTALL information then reloads RAM with the selected *temporary*, *preferred*, or *default* install release (stored in flash) and runs this code.

The release is uncompressed as it loads to RAM. This may take 10–30 seconds. At this point, any required patches are loaded from the flash file system. Any patch is also uncompressed as it loads to RAM. This procedure ensures that the code runs at maximum speed, and allows updates to be made to the code. Updates can be downloaded over the network from a TFTP server and stored in the flash file system until required at power-up.

To download software onto the router, see the *Upgrade* chapter in the Software Reference.

All router software, patches, and configuration settings are stored as files in flash memory. Typically, the following files will be present in flash:

- The current installed software release. Additional software releases may also be present.
- The current installed patch, if any. Additional patches may also be present.
- The command line help file. All command help is stored in a separate text file designed to be language independent. The command help file is loaded with a software release.
- The boot script `boot.cfg`. The boot script contains standard router commands (executed on start-up to configure the router).
- Additional user-defined configuration scripts containing commands to configure the router for different functions. These scripts are created using the built-in editor, the **add script** command (in the *Scripting* chapter, Software Reference), or the **create config** command (in the *Upgrade* chapter, Software Reference).

Configuration information is stored in flash memory as configuration scripts. These scripts contain standard router commands. When a configuration command is entered at the command prompt from a terminal, terminal emulation program, or Telnet session, the command alters the dynamic configuration only; this is not saved over a power cycle. To ensure that configuration changes resulting from such commands are retained across a power cycle, the dynamic configuration must be saved as a configuration script, using the **create config** command.

Start-up process When the router starts up following either a power cycle or an operator-initiated reboot (using the **restart reboot** command in the *Upgrade* chapter, Software Reference), the following sequence of operations is performed:

1. Perform start-up self tests.
2. Load the flash boot block release as the INSTALL boot into the router's RAM.
3. Prompt the manager for changes to the default start-up procedure:

```
Force EPROM download (Y)?
```

The manager may press one of the keys listed in the table in [“Router start-up sequence keystrokes” on page 17](#) to override the default installation procedure.

4. Check the INSTALL information to determine which release to load and run, according to the INSTALL parameters, and the manager's response to the previous prompt. The INSTALL parameters determine which release and patch the router loads and runs, unless you press one of the keys in the table in [“Router start-up sequence keystrokes” on page 17](#).
5. Load the required release specified by the INSTALL parameters from the flash file system as the main boot.
6. Start the router.
7. Execute the boot configuration script, if one has been configured. The boot configuration script is either a configuration file set using the **set config** command from the *Upgrade* chapter, or the file boot.cfg file, if there is one.)

The router sends a series of start-up messages to asyn0 (the console or terminal port). For an example see the following figure.

Example start-up messages

```
INFO: Self tests beginning.
INFO: RAM test beginning.
PASS: RAM test, 65536k bytes found.
INFO: Self tests complete
INFO: Downloading router software.
Force EPROM download (Y) ?
INFO: Initial download successful
INFO: Initialising Flash File System.
INFO: IGMP packet trapping is active for IGMP snooping, L3FILT
is activated
INFO: Executing configuration script <flash:boot.cfg>
INFO: Router startup complete

Login:
```

After the self tests are complete, the manager is given the option of forcing a mandatory boot from the flash boot block release. The following message is displayed on the terminal connected to the console port (asyn0) and the router pauses:

```
Force EPROM download (Y)?
```

Router start-up sequence keystrokes

If a key is not pressed within a few seconds, the start-up process continues and all steps in the start-up sequence are executed. Pressing certain keys on the terminal immediately after the “Force EPROM download” message is displayed changes the router start-up process as described in the following table.

Pressing key...	Forces the router to...
(no key pressed)	After a few seconds, the router start up process continues.
[Y]	Load the release, without any patches, from ROM onto the RAM, and run the full release.
[S]	Load and run the release and patch determined by the INSTALL parameters from flash, ignoring any boot script or previous configuration stored in flash memory.

Router start-up message classes

During the start-up process the router generates four different types of messages. All messages are preceded by one of the words INFO, PASS, FAIL, or ERROR. The meaning of these words in the context of the messages is shown in the following table.

Message	Meaning
INFO	An informational message that an action has been taken by the system.
PASS	An informational message that a test has been completed successfully.
ERROR	An error message that a test has failed, but the system will continue to operate.
FAIL	An error message that a fatal error condition has caused the system to halt in an unrecoverable fashion.
WARNING	A serious error has occurred, which may indicate hardware failure.

Messages and their meanings are:

INFO: Self tests beginning.

The code loader tests are about to begin.

INFO: RAM test beginning.

The RAM tests are about to begin.

PASS: RAM test, 65536k bytes found.

The RAM test passed, and the indicated amount of memory was found and will be used in the router. (The amount of memory depends on the router model.)

ERROR: RAM test 5. Error address = 00345678.

A RAM test failed, at the given address. In the example, it was the fifth test run. The RAM test repeats until it passes, so a number of messages like this may appear. This fault means that the memory system is faulty. If the fault continues, contact your distributor or reseller immediately.

INFO: Self tests complete.

The start-up tests have finished.

INFO: Downloading router software.

The process of downloading the router software from ROM is about to begin.

ERROR: Code load retried.

FAIL: Code load failed.

The load of the code from ROM to RAM failed. The load is retried a number of times. Each time a failure occurs the ERROR message is displayed. If the maximum number of attempts is reached, the FAIL message is displayed.

ERROR: Vector load retried.

FAIL: Vector load failed.

The load of the *vector table* from ROM to RAM failed. The load is retried a number of times. Each time a failure occurs the ERROR message is displayed. If the maximum number of attempts is reached, the FAIL message is displayed. Contact your authorised Allied Telesyn distributor or reseller.

INFO: Initial download successful.

The start-up tests and download from ROM are complete, and the specified router software is about to be started. It takes a few seconds to decompress the software release.

FAIL: Unexpected exception. Offset = 40, Addr = 0100045e.

An unexpected exception occurred while the start-up was executing. The vector offset and the program counter when the exception occurred are given in the message. Contact your distributor or reseller.

INFO: Executing configuration script <script-name>

The configuration commands stored in <script-name> are being executed. If an error is found in the script, one or more ERROR messages will be displayed.

INFO: Router startup complete.

The start-up process is complete and the router is now operational.

INFO: Initialising Flash (This may take some time)

The flash file system was found to be corrupt. The router is now re-initialising the flash device to a "good" state. The process will take at least 4 minutes, depending on the router.

INFO: IGMP Snooping is activated.

IGMP snooping has been enabled.

INFO: IGMP packet trapping is active for IGMP snooping, L3FILT is activated

IGMP snooping has been enabled.

WARNING: IGMP Snooping not active, failed to enable ports.

The IGMP snooping could not be activated on the switch ports. This may indicate a hardware failure. Contact your authorised distributor or reseller.

Flash Memory

Flash memory is a non-volatile, reprogrammable, memory storage device for router software releases, allowing upgrades to be remotely loaded from any WAN or LAN port. Flash memory is also used to store other types of data such as patches, logs and configurations.

Testing flash memory

There are several ways to check that onboard flash memory is installed and operating correctly. First, check that the router has recognised the flash memory by displaying system information ([Figure 1](#)) with the command:

```
show system
```

Figure 1: Example output from the **show system** command for the AT-AR450S router

```
Router System Status                               Time 02:25:09 Date 25-May-2004.
Board      ID  Bay Board Name                               Rev    Serial number
-----
Base       191  AR450                               M1-0   57681308
-----
Memory -   DRAM : 65536 kB   FLASH : 16384 kB
-----
SysDescription
Allied Telesyn AR450 version 2.6.1-00 20-Aug-2003
SysContact

SysLocation

SysName

SysDistName

SysUpTime
310708 ( 00:51:47 )
Boot Image      : 450_107.fbr size 874084 11-May-2004
Software Version: 2.6.1-00 20-Aug-2003
Release Version : 2.6.1-00 20-Aug-2003
Patch Installed : NONE
Territory       : usa
Help File       : help.hlp

Configuration
Boot configuration file: ip.cfg (exists)
Current configuration: ip.cfg

Security Mode    : Disabled

Warning (2048284): No patches found.
```

The second part of the display shows the types and sizes of memory installed in the router. If the flash memory size is lower than expected, then the router's boot process has not correctly detected or recognised the flash memory's presence. If recognition fails, contact your authorised Allied Telesyn distributor or reseller.

If the flash is recognised, display flash memory size, device type, and location with the command:

```
show flash physical
```

A typical display is shown in [Figure 2 on page 20](#).

Figure 2: Example output from the **show flash physical** command for an AR450S

```

total size ..... 16 MBytes
  available to FFS ... 15 MBytes
  available to boot .. 1 MBytes
device type ..... 28F128
devices ..... 1
location ..... built in
programming power ..... off
block erase time ..... 1000 milliseconds
total erase blocks .... 128
  FFS erase blocks ... 120
  Boot erase blocks .. 8
erase block size ..... 128 kBytes
erase bit state ..... 1
page buffers ..... 1
size of page buffer ... 32 bytes

```

Lastly, check the Flash File System (FFS) to ensure that it has successfully formatted the flash. Use the command:

```
show file
```

If flash memory has been used in the past, it may already be formatted and contain files. With erased or new flash memory that has been correctly formatted, an 80 byte hidden system file is present. A typical display for an FFS is shown in [Figure 3 on page 20](#).

Figure 3: Example output from the **show file** command for an AR450S

Filename	Device	Size	Created	Locks
450-252a.hlp	flash	140586	09-May-2003 17:01:15	0
54-252.rez	flash	2316676	11-Dec-2003 08:49:27	0
54-261.rez	flash	2424476	21-Aug-2003 12:11:56	0
54252-03.paz	flash	150916	11-Dec-2003 08:55:25	0
config.gui	flash	363	04-Mar-2004 15:16:09	0
config.ins	flash	32	11-Dec-2003 14:00:07	0
d450se02.rsc	flash	2303244	11-Dec-2003 09:00:23	1
feature.lic	flash	39	25-Jun-2003 13:41:29	0
random.rnd	flash	3904	02-Mar-2004 09:14:48	0
release.lic	flash	64	28-Mar-2003 23:29:14	0
ssh.key	flash	321	02-Apr-2003 23:18:14	0

Asynchronous Interfaces

Asynchronous interfaces on the router, also known as RS-232 (V.24) terminal ports (labelled ASYN0, ASYN1, RS-232 or CONSOLE) use DB9 male connectors. The default communications settings are:

- 9600 bps
- 8 data bits
- 1 stop bit
- no parity
- hardware flow control

The pin wiring is shown in the following table, matches most building wiring schemes.

Pin*	Function	Signal Direction
1	DCD	Input to router
2	RXD	Input to router
3	TXD	Output from router
4	DTR	Output from router
5	GND	
6	DSR	Input to router
	<i>AR450S: Not connected</i>	
7	RTS	Output from router
8	CTS	Input to router
9	<i>Not connected</i>	

* Pins are numbered from left to right.

The pin wiring for the RJ-45 connectors on the AR024 4ASYN PIC is described in the *Port Interface Card Hardware Reference*.

Asynchronous interfaces follow the RS-232 standard. A range of speeds is selectable using the **set port** command (*Interfaces* chapter, Software Reference).

Not all signals need to be connected. In particular, both DCD and CTS are not required unless the interface has been specifically set up to use them. See the *Terminal Server* chapter, Software Reference for more details. A typical terminal connection requires only RXD, TXD and GND, but refer to the equipment manual for the connected device for more specific data.

Port Interface Cards (PICs)

You can install a PIC (Port Interface Card) in any AR400 Series routers except the AR450S. The sections describing each router model (earlier in this Reference) list the PICs that can be installed in each model. Installation information for PICs is in the *Port Interface Card Quick Install Guide*. Detailed PIC hardware information is in the *Port Interface Card Hardware Reference*.

The PIC Quick Install Guides and Hardware References are included on the Documentation and Tools CD-ROM bundled with all AR400 Series routers. They can also be downloaded from the Support Site at www.alliedtelesyn.com/support/software/.

RS-232 Terminal and Modem Cables

This section describes how to make cables for connecting the router to networks, terminals, and printers.

- “DB9 female to DB9 female cable”
- “DB9 female to DB9 male cable” on page 23

For information about cables to connect to an AR024 ASYN 4 PIC, see the *Port Interface Card Hardware Reference*.

The RING input is available only on asynchronous ports on expansion cards. It is not available on asynchronous ports on base CPU boards.

DB9 female to DB9 female cable

To connect the router’s asyn port to a PC, terminal or router with a DB9 male connector wired as DCE, use a DB9 female to DB9 female null modem cable wired as in the following diagram.

Figure 4: Cable wiring for DB9F to DB9F cable (DTE to DTE) (null modem)

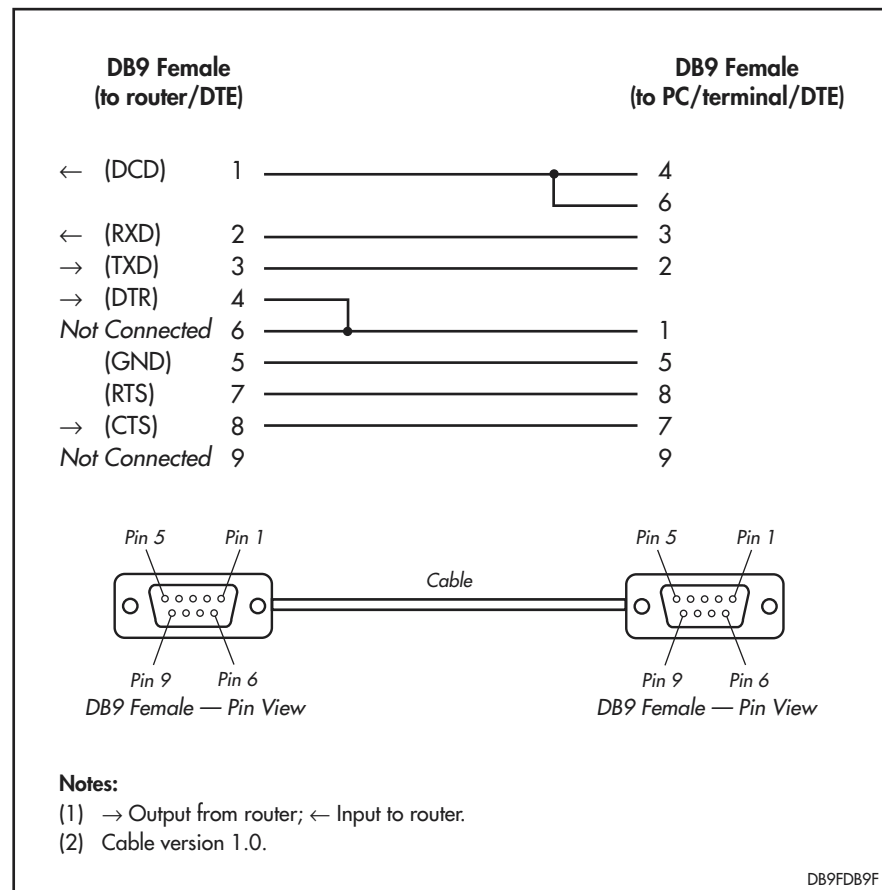

DB9 female to DB9 male cable To connect the router's asyn port to a modem with a DB9 female connector wired as DCE, use a cable wired as in the following diagram.

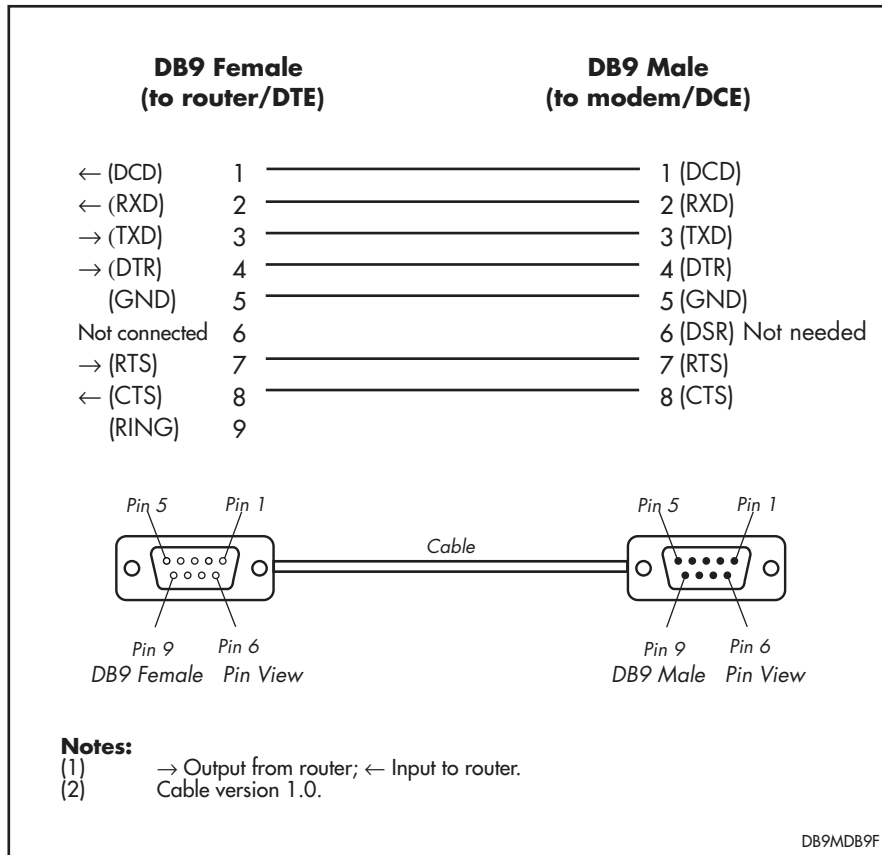

Test Facility

A Test Facility designed to test the router's physical interfaces and expansion options is built into the router software. The Test Facility can be thought of as a specialised interface module like PPP or Frame Relay. Although the router can continue to operate normally during specific tests, any interfaces being tested are dedicated to the Test Facility. For more information on the Test Facility's operation, see the *Test Facility* chapter, Software Reference.



Caution Do not connect to the router via a port you are testing.

The routers and PICs support a wide range of interface types, including Ethernet, asynchronous, synchronous, Basic Rate ISDN and Primary Rate ISDN. Each interface type (except Ethernet interfaces on the AT-AR026 PIC) can be tested independently using the Test Facility software. Most tests, however, will also require the use of a loopback plug. See [“Loopback Plugs” on page 26](#).

The following examples show how to test specific interfaces. If a test fails, contact your authorised Allied Telesyn distributor or reseller.

To display test results, use the command:

```
show test
```

The following figure shows sample output from the **show test** command.

Figure 5: Example output from the **show test** command on an AR450S

Board	ID	Bay	Board Name	Rev	Serial number
Base	190		AR450	M1-0	57687095

Interface	State	Result	Type	Duration	Details		
				(minutes)	Data(%OK)	Control	
eth0	complete	good	trans	0	-	-	-
			TP	2	good(100.0)	-	
			ENDEC	0	-	-	-
			MAC	2	good(100.0)	-	
eth1	complete	good	trans	0	-	-	-
			TP	2	good(100.0)	-	
			ENDEC	0	-	-	-
			MAC	2	good(100.0)	-	
port1	complete	good	-	2	good(100.0)	-	-
port2	complete	good	-	2	good(100.0)	-	-
port3	complete	good	-	2	good(100.0)	-	-
port4	complete	good	-	2	good(100.0)	-	-
port5	complete	good	-	2	good(100.0)	-	-
asyn0	complete	good	-	1000	good(99.0)	good	-
enco0	no test	-	-	-	-	-	-

Asynchronous interface test Asynchronous interfaces require a loopback plug to be installed before the test will operate. See “[Loopback Plugs](#)” on page 26 for details of how to make a loopback plug. To start a test of an asynchronous interface, use the command:

```
enable test int=asynn
```

where *n* is the interface number. This runs the test for 4 minutes. Use the **show test** command (*Test Facility* chapter, Software Reference) to observe the test progress.

Ethernet interface test for eth and switch ports A loopback plug is required to run the first part of the Ethernet test. See “[Loopback Plugs](#)” on page 26 for details of how to make a loopback plug. To start a test of an eth interface, use the command:

```
enable test int=ethn
```

where *n* is the Ethernet interface number.

To start a test of a switch port, use the command:

```
enable test int=portn
```

where *n* is the switch port number.

This runs the test for 4 minutes. Use the **show test** command (*Test Facility* chapter, Software Reference) to observe the test progress.

AT-AR026 PICs The Test Facility does not test AT-AR026 4ETH PICs.

ADSL interface tests No loopback plug is required to test an ADSL interface. To start a test of an ADSL interface, use the command:

```
enable test int=adsln
```

where *n* is the interface number. Use the **show test** command (*Test Facility* chapter, Software Reference) to observe the test progress.

WAN port tests To fully test synchronous interfaces, an external tester (available from your authorised Allied Telesyn distributor or reseller) is required. A loopback plug is not required to test BRI interfaces.

To start a WAN interface test, use the command:

```
enable test int=synn
```

or

```
enable test int=brin
```

where *n* is the WAN interface number. This runs the test for 4 minutes. Use the **show test** command (*Test Facility* chapter, Software Reference) to observe the test progress.

Loopback Plugs

Loopback plugs are used in conjunction with the Test Facility software (see the *Test Facility* chapter) to test the router's physical interfaces. The purpose of a loopback plug is to connect the output pins on the interface to the input pins so that any data transmitted over the interface is looped back and received at the same interface.

On interfaces with control signals, these are also looped back. The data received on the interface is compared with the data transmitted to determine whether or not the interface is functioning correctly. In order to produce a comprehensive test report, most tests performed by the Test Facility require a loopback plug to be inserted in the interface being tested.

Some interfaces (e.g., the synchronous ports) require a specially built external testing device (available from your authorised Allied Telesyn distributor or reseller) to be used in conjunction with the Test Facility.

Asynchronous port loopback plug

To test an asynchronous (RS232/Console) port, use a loopback plug as described in the following figure.

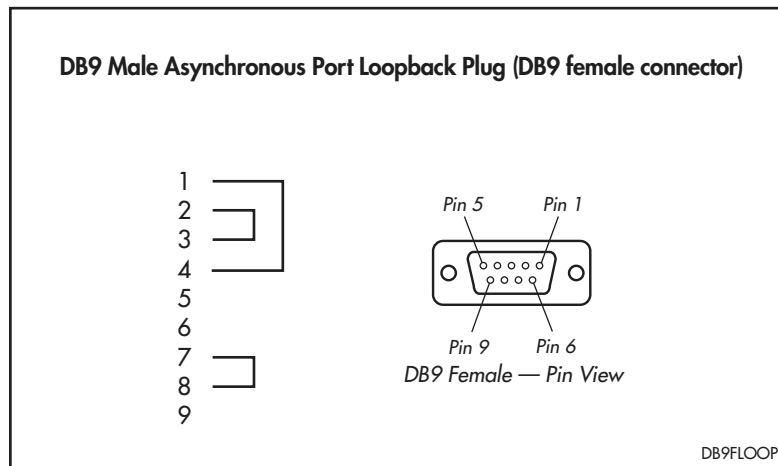

Switch or eth port loopback plug

To test an eth or switch port, use a loopback plug as described in the following figure.

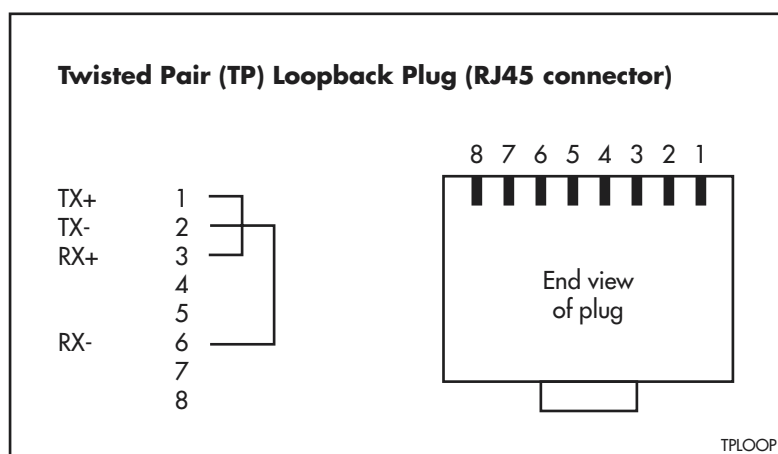

Restricted Procedures

Diagnostics

The router software includes a set of diagnostic programs. These programs perform basic level checks of all system components. They do not run in conjunction with the normal operating code, and require that the system be totally dedicated to their use. A detailed knowledge of the way your router hardware functions is necessary if diagnostics are to be used effectively.



Caution Diagnostic mode should be used by authorised service personnel only. Unauthorised use of diagnostic mode may cause the router to cease functioning.

To enable diagnostics mode

The router does not function as a router while diagnostic mode is running. Diagnostics do not perform checks on AT-AR026 PICs.

1. Connect a terminal to the console port.

Connect a terminal to the console port (port 0) on the router's rear panel, and set the terminal communications parameters to:

- 9600bps
- 8 data bits
- 1 stop bit
- No parity
- Hardware flow control.

2. Restart the router.

Restart the router, either by switching it off and on again using the power switch on the rear panel, or by using the terminal to login and enter the command:

```
restart reboot
```

3. Enable diagnostics mode during start-up.

During the router start-up process, press [Ctrl/D] on the terminal to enter diagnostics mode when you see the following prompt:

```
Force EPROM download (Y)?
```

A banner page is displayed on the terminal (see figure following). This can be used to check that the terminal is correctly connected.

```
* * * Diagnostic Mode * * *  
  
version: 1-Jul-2004  
  
Main Menu:  
  0. Restart  
  1. Full RAM test  
  2. ROM checksum test  
Enter selection ==>
```

To run a diagnostic program, enter the corresponding letter or number. There are several sub-menus to cover the different options. The following table lists keys that control the basic operation of the diagnostics.

Key	Function
Q	Quits any running tests and displays the banner page.
S	Prints a summary of test results so far.

Diagnostics are designed to be used with all models of the router, and therefore some instances of particular tests are not appropriate for some models. A reasonable level of understanding of the system structure is needed to operate diagnostics and interpret the results. Diagnostics only require the base CPU board to be installed in the system.

To restore the router to normal operation, perform a restart by switching its power switch (rear panel) OFF and ON.

For more information This hardware manual is not intended as a guide to diagnostics. Diagnostics are designed to be run by service personnel only. For more information, contact your authorised Allied Telesyn distributor or reseller.

Lithium Battery Replacement

The routers have a replaceable lithium battery. If replacing the battery, use a 3V lithium button cell, type CR2032 or equivalent.

The battery should be replaced when the router:

- has been in storage for more than two years
- has only been powered up intermittently over a two year period
- loses its time setting



Warning Batteries should be replaced by authorised service personnel only. Unauthorised opening of the router lid may cause danger of injury from electric shock, damage to the router, and invalidation of the product warranty.

Contacting Us

With locations covering markets in North America, Latin America, and Europe, Allied Telesyn provides local sales and technical support worldwide. To find the representative nearest you, visit Allied Telesyn on the Internet at www.alliedtelesyn.com.