

Chapter 6

ATM over ADSL

| | |
|--|------|
| Introduction | 6-3 |
| What is ADSL? | 6-3 |
| ADSL Network Components | 6-4 |
| ADSL Performance | 6-5 |
| How Does ADSL Work? | 6-5 |
| ADSL Frames and Superframes | 6-6 |
| ADSL Network Connection Process | 6-7 |
| Dying Gasp | 6-7 |
| What is ATM? | 6-8 |
| ATM Cells | 6-8 |
| ATM channels | 6-8 |
| ATM Service Categories | 6-8 |
| Data Layers above ATM | 6-9 |
| Connection Types Used over ATM | 6-10 |
| RFC 1483 Bridged or Routed - Alternative Definitions | 6-10 |
| Typical settings for ATM over ADSL | 6-12 |
| ADSL and ATM Support on the Router | 6-13 |
| Virtual ETH interfaces | 6-13 |
| Configuration Procedures and Examples | 6-14 |
| Configure PPPoE over ATM | 6-15 |
| Configure PPP over ATM (PPPoA) | 6-17 |
| Configure ATM RFC 1483 Routed* | 6-19 |
| After configuring ATM | 6-20 |
| Command Reference | 6-21 |
| add atm channel | 6-21 |
| create atm | 6-23 |
| create eth | 6-24 |
| delete atm channel | 6-25 |
| destroy atm | 6-25 |
| destroy eth | 6-26 |
| disable adsl | 6-26 |
| disable adsl debug | 6-27 |
| disable atm channel | 6-27 |
| enable adsl | 6-28 |
| enable adsl debug | 6-28 |
| enable atm channel | 6-29 |
| reset adsl | 6-29 |
| reset adsl counter | 6-30 |
| set adsl | 6-30 |
| set atm channel | 6-32 |
| set system country | 6-34 |

| | |
|-------------------------|------|
| show adsl | 6-35 |
| show adsl counter | 6-37 |
| show atm | 6-39 |
| show atm channel | 6-41 |
| show atm counter | 6-43 |

Introduction

This chapter describes Asymmetric Digital Subscriber Line (ADSL) technology, Asymmetric Transfer Mode (ATM), their implementation on the router, and how to configure the router for ATM over ADSL.

What is ADSL?

Definition ADSL is one of range of Digital Subscriber Line (DSL) technologies (xDSL) that use existing twisted-pair telephone lines (POTS, Plain Old Telephony System) to transport high-bandwidth data, such as multimedia and video, to service subscribers. xDSL can deliver high-bandwidth data rates to dispersed locations with relatively small changes to the existing telecommunications infrastructure. xDSL services provide dedicated, point-to-point, public network access over twisted-pair copper wire either on the local loop ("last mile") between a network service provider's (NSPs) central office and the customer's site, or on local loops created either intra-building or intra-campus. ADSL is:

- **Asymmetric**, because data transmission is faster downstream to the subscriber than upstream from the subscriber,
- **Digital**, because even voice and video are digitised before they are transmitted as modulated analogue representations of digital data,
- **Subscriber Line**, because data is carried over a single twisted pair copper 'loop' to the subscribers premises.

ADSL in the OSI Model In the seven layer OSI model, ADSL is at the Physical Layer (Layer 1), an encoding technology over which may be deployed higher layer protocols, such as ATM. The Physical Layer handles the basic ADSL encoding, data rates, and offers compatibility with other technologies in the subscriber line. For example, ADSL can share the line with a POTS service.

Why use ADSL? Typically Web browsing involves downloading five times as much data as it transmits, so customers do not need a high bi-directional transmission speed. ADSL also allows service providers to limit web hosting on subscriber lines, or sell it separately; a web server cannot run effectively over ADSL.

ADSL Network Components

The main hardware components, shown in [Figure 6-1](#) and listed below, are required for a typical ADSL network connection.

Figure 6-1: Main network components for ADSL

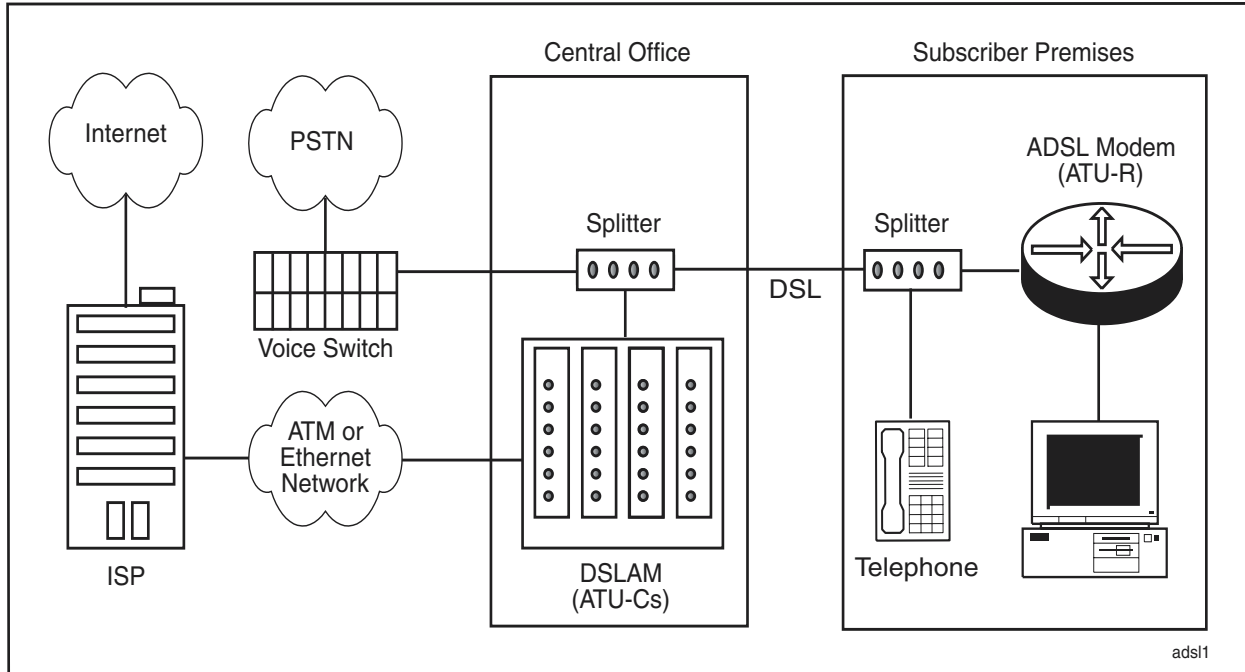

- **ADSL Modem (ADSL Transmission Unit Remote, ATU-R)**

The ADSL modem at the customer premises, also known as ADSL Transmission Unit Remote (ATU-R), provides local loop termination on the customer side. It may also operate as either a router or a bridge.

- **ADSL Transmission Unit Central Office (ATU-C)**

The ADSL modem at the central office, or ATU-C, terminates the ADSL local loop at the central office premises. Many ATU-Cs can be inserted into a DSLAM.

- **DSL Access Multiplexor (DSLAM)**

The ATU-C units are collected together in a chassis unit called a DSLAM. The DSLAM may also incorporate a splitter. The DSLAM can connect through an ATM or Ethernet access network to the Internet.

- **ADSL Splitter**

The splitter is an electronic low pass filter that separates the analogue voice or ISDN signal from ADSL data frequencies. There is a splitter located at the central office and at the subscriber premises. The splitters are totally passive devices requiring no power. This means that a power outage that stops the ADSL modem does not affect the telephones, which can continue to operate normally. The splitter at the central office may be incorporated into the DSLAM, or may be a separate device.

ADSL Performance

Downstream data rates can be as high as 12Mbps, while upstream rates are typically around 1Mbps. There are a number of factors which can affect frequencies in the DSL band differently to reduce available bandwidth. Each copper line has different impairment characteristics resulting from:

- The length and gauge of the line. The greater the line length, the greater the attenuation and the narrower the gauge, the greater the attenuation.
- Bridge taps on the line causing reflections and noise;
- Crosstalk from other wires in the same bundle, for instance other T1 lines, depending on their relative position;
- RF interference from AM radio, amateur radio bands, and interference from other sources.

ADSL cannot be transmitted on a line with load coils or Digital Loop Carriers (DLCs).

How Does ADSL Work?

DSL transmission technology, including ADSL, exploits the fact that all telephony signals are below 4kHz in frequency, although a typical copper-pair line can transmit usable signals up to approximately 1Mhz. ADSL uses the rest of the full copper line frequency spectrum, from above the voice frequencies up to 1.1 Mhz.

A device called an ADSL splitter separates the voice frequencies from the data frequencies when they get to the subscriber premises. For outgoing traffic, it combines the voice and data frequencies onto one line when they are transmitted from the subscriber premises. This allows a POTS phone connection to operate at the same time as ADSL digital data is transmitted or received on the same line. The ADSL splitter uses passive filters, so the voice line remains available even if the ADSL system fails.

DMT modulation ADSL transmitters use Discrete MultiTone modulation (DMT), rather than its earlier competitor Carrierless Amplitude Phase modulation (CAP). DMT splits the available frequency range up into sub-bands. There are nominally 224 downstream frequency bins, or carriers (each occupying about 4 kHz of spectrum) and 32 upstream frequency bins (also each occupying approximately 4 kHz of spectrum). If the line is of good quality, up to 15 bits per signal can be encoded on each carrier frequency.

DMT has a number of advantages over CAP:

- Adapting to impairments

Because DMT is able to individually tune the throughput at many different frequencies, it can optimally adapt to impairments affecting different frequencies differently. The ADSL we use today, based on DMT, is sometimes referred to as Rate-Adaptive DSL because the data rate being transmitted can be adapted to the quality of the line.

- Reduce RF interference

To prevent RF interference from the DSL at amateur radio frequencies, a DMT ADSL transmitter turns off certain sub-channels in the spectral region used by amateur radio.

- Impulse Noise Handling

Impulse noise, a common problem in copper access networks, is generally caused by switching transients from ring generator relays in central offices or electric motors on the customer premise. DMT helps diminish impulse noise. An impulse may wipe out the receive signal for 5 μ s (microseconds) or more, but a DMT symbol spans 250 μ s. An impulse will therefore destroy only some of the sample.

ADSL Frames and Superframes

A single ADSL frame contains as many bits as can be sent onto the line in a single time-slice. The bits are distributed across all the active DMT frequencies, in accordance with the number of bits-per-signal being used on each frequency.

After 68 such frames have been sent, there will always be a special synchronisation frame sent. This combination of 68 normal frames and one sync frame is referred to as an ADSL superframe.

The data in the ADSL transport is organized into the following items:

- **Frames** - where each frame starts on a 250 μ s time boundary. While the timing of the frames remains constant, the actual size and contents of the frames can vary on the basis of the prevailing transport mode.
- **Superframes** - these represent the highest level of data presentation and repeat every 17 ms. Each superframe contains sixty-eight ADSL frames, one of which is used to provide superframe synchronization, identifying the start of a superframe. Some of the remaining frames are also used for special functions.

Both the frames and superframes have an inherent organization, providing structure for synchronisation. Each frame ([Table 6-2](#)) contains:

- The **Fast Byte** is used for special superframe-related processing functions.
- The **Fast Data** transmits time-sensitive information such as audio, and is not retransmitted. This can vary in length.
- **Forward Error Correction (FEC)** is used to ensure the accuracy of the fast data.
- **Interleaved Data** is the user data that the ADSL interface transmits, typically data network payload such as Internet data. This can vary in length.

Figure 6-2: ADSL frame

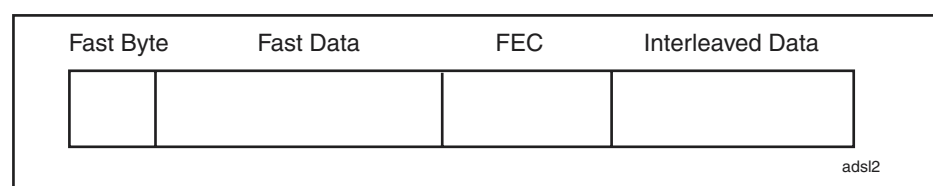

ADSL Network Connection Process

When an ADSL modem/router connects to a DSL network, it goes through an initialization process. This process identifies and qualifies both the capabilities of the network equipment and of the underlying physical infrastructure. The initialization process consists of four major phases (Table 6-1).

Table 6-1: ADSL initialisation process

| Phase | Name | What happens ... |
|-------|--------------------------------|---|
| 1 | Activation and Acknowledgement | Power on takes the modem into activation and acknowledgment stage. The goals of initialisation are to determine which tones can be used and assign bits to each tone. Initialisation uses two pilot tones that start the activation. Normally the modem initiates the process when it is turned on and connected to the DSL line. Messages are sent using the pilot tones to ensure that both ends are ready for transceiver training. |
| 2 | Training | During transceiver training the ATU-C measures and adjusts power output and how it will equalise the circuit. Unless configured otherwise, it will negotiate the fastest possible speed for the local loop. Training does not interfere with the POTS or ISDN phone service. |
| 3 | Channel Analysis | During transceiver training the modem goes into the channel analysis phase where the ATU-C in the DSLAM tells the subscriber modem which options are configured and sends a predefined medley of tones so the modem can report its signal-to-noise ratio. |
| 4 | Exchange | During the exchange phase, the ATU-C in the DSLAM sends the minimum signal-to-noise ratio and decides on the power output per tone. |
| 5 | Show Time | Initialisation concludes with Show Time , in which the ADSL line is active and higher layer protocols such as ATM can begin negotiation to transfer data over the connection. |

Dying Gasp

If the ADSL device at the subscriber premises supports Dying Gasp, it sends a dying gasp signal to the DSLAM when it is disabled, or powered down. The DSLAM can record this message, so that a network administrator can use it for diagnostic purposes. It shows that the connection went down because of loss of power at the customer premises, and not because the cable was accidentally cut between the subscriber and the service provider.

What is ATM?

Asynchronous Transfer Mode (ATM) is a high speed Link Layer (Layer 2) network protocol. ATM can be used to provide access to the physical layer, such as ADSL, for higher layer protocols such as PPP and TCP/IP. ATM is one of the key technologies for enabling broadband on ADSL, and is well suited to such purposes as realtime voice and video.

ATM Cells

ATM is transmitted as cells of equal size; each cell has 53 bytes, of which the first 5 bytes are the cell header, and the last 48 bytes are payload.

Figure 6-3: Basic ATM cell structure

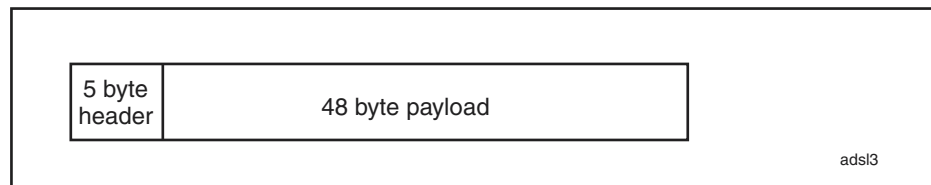

ATM channels

A typical ATM network consists of a mesh of ATM switches that switch cells in many directions. To enable the ATM switches to direct cells correctly to their destination, virtual channels are defined through the network. This creates an imaginary line through the network connecting any two given edge devices.

All the switches along this path have information about this channel, including the direction to the next switch along the channel. When device A sends a cell to device B, it includes in the cell information to identify the virtual channel (VC). The switches recognise this, and forward the cell accordingly. Two parameters define the VC, to enable fast forwarding of cells in the core of the network, and accurate routing at the edge. Effectively, a number of virtual channels that are all going in the same general direction are logically bundled together into a virtual path.

■ Virtual Path Identifier (VPI)

There are fewer Virtual Paths in the network than Virtual Channels. Core switches forward cells on the basis of the VPI, looking the route up quickly in the relatively short list.

■ Virtual Channel Identifier (VCI)

As a cell approaches its destination, switches forward it on the basis of its VCI in order to get it to its own unique destination.

ATM Service Categories

Each ATM VC has Quality of Service (QoS) information associated with it. Each switch along the channel can queue, prioritise or drop cells belonging to any particular channel based on the following service categories:

■ Constant Bit Rate (CBR).

CBR traffic requires guaranteed levels of service and throughput. The network undertakes to transport the cells of a CBR channel at a specified

constant bit rate. This would typically be used for VCs that are carrying delay sensitive applications, such as video and voice, which require a continuous bit stream.

- **Variable Bit Rate (VBR).** There are two variable bit rate service categories.

Variable Bit Rate - non-real time (**VBR-nrt**) is used by applications that produce traffic of varying bit rates, which produce varying throughput rates, and which are able to tolerate delay (for example, email).

Variable Bit Rate - real time (**VBR-rt**) is used by applications that produce traffic of varying bit rates, which produce varying throughput rates, and which are intolerant of delay. The network allows such a VC some leeway in its throughput rate, and undertakes to minimize latency in forwarding its cells.

- **Unspecified Bit Rate (UBR).**

The UBR service category does not specify traffic related service guarantees. Specifically, UBR does not include a per-connection negotiated bandwidth. The network makes no numerical commitments about the cell loss ratio or the cell transfer delay for cells on a UBR VC.

- **Available Bit Rate (ABR)**

The ABR category of service allows the setting of both minimum and peak cell rates.

For some of the service categories, there are other parameters that also need to be specified:

- **Peak Cell Rate (PCR)** is the maximum transfer rate that the VC is permitted to transmit.
- **Minimal Cell Rate (MCR)** is the minimal transfer rate that the network guarantees to provide for the VC.
- **Sustainable Cell Rate (SCR)** is the mean transfer rate that the network guarantees to provide for the VC.
- **Maximum Burst Size (MBS)** is a how many cells may be sent at the Peak Cell Rate for the VC. This is used to calculate the Burst Tolerance for the connection.

Data Layers above ATM

ATM Application Layer 5 (AAL5) splits higher layer packets up and puts them into ATM cells for transmission, adding padding as necessary to form good ATM cells. At the receiving end of the link, it extracts the data from cells received, and passes them up to the higher layer.

Implementations of ATM commonly use one of the definitions in RFC 1483 for encapsulating different protocols in ATM cells, so that the receiving end can correctly identify the protocol:

- **Virtual Channel Multiplexing (VCMux):** Using this method, multiple VCs are created on an ADSL link, and a different protocol can be sent over each VC. Then, the receiver knows that all the packets arriving on a particular VC belong to a particular protocol.
- **LLC/SNAP encapsulation:** In this method, only one VC is used. Extra headers are put into the front of data packets before they are passed to the

AAL5 process to be cut up into ATM cells. The main purpose of these headers is to hold a field that specifies the protocol type of the enclosed data packet. RFC 1483 also defines two different types of LLC/SNAP headers: 'RFC1483 Routed' and 'RFC1483 Bridged'.

Connection Types Used over ATM

The DSLAM that an ADSL modem connects to may have either an ATM uplink port to an established ATM based network, or an Ethernet uplink port to connect to an Ethernet-based ADSL network. There are a number of ways protocols can be combined and sent over AAL5 over ATM, to suit different network architecture.

- **PPPoA.** This is the logical choice for enabling individual clients to gain internet access over an ATM-based network. The PPP layer is introduced in order to make use of the already very popular features of PPP, like authentication, link monitoring, IP address assignment, DNS address assignment. The exact format of the RFC1483 header put onto the PPP packets is defined in RFC2364.
- **PPPoE.** This stack is the logical choice for enabling individual clients to gain internet access over an Ethernet-based network (but it is even used over ATM-based networks). As with PPPoA, it gets all the advantages of PPP, but at the cost of some extra packet overhead. The PPPoE packets are encapsulated using the RFC1483 Bridged method.
- **IPoA.** This was designed in an attempt to make IP subnets map directly onto ATM networks in the same way that IP subnets map onto VLANs. So, an ATM address resolution protocol was introduced that enabled the IP stack to obtain an "ATM address" for another IP host connected to its local ATM subnet (RFC 2225). The structure required to make this kind of network operate is rather complex, mostly because trying to make a channel-oriented transport like ATM appear like a broadcast domain is not a very natural fit.
- **RFC 1483 Bridged.** In this method, the whole Ethernet packet that arrives on the Ethernet side of the ADSL modem is encapsulated into AAL5, using the 'bridged-data' format defined in RFC 1483, and sent on the ADSL line. The modem forwards packets based on their MAC addresses, that is, it bridges the packets. (See also the definition below.)
- **RFC 1483 Routed.** In this method, the whole Ethernet packet that arrives on the Ethernet side of the ADSL modem is encapsulated into AAL5, using the 'bridged-data' format defined in RFC 1483, and sent on the ADSL line. The modem forwards packets based on their IP addresses, that is, it routes the packets. (See also the definition below.)

RFC 1483 Bridged or Routed - Alternative Definitions

The terms "RFC1483 Routed" and "RFC1483 Bridged" have been used in different ways by different vendors and ISPs. Understanding the possible interpretations of these terms will make it easier to find an ATM configuration that matches your ISP's requirements.

Interpretation 1 (Not used in this document)

Interpretation 1 follows the RFC's definition of the terms "RFC1483 Routed" and "RFC1483 Bridged". RFC1483 defines a format for encapsulating 'Routed Protocols', and a format for encapsulating 'Bridged protocols'. The essential difference between these two definitions is that in the case of "Routed" protocols, the layer-3 frame is directly encapsulated in the RFC1483 header;

whereas in the case of "Bridged" protocols, the layer-3 frame is encapsulated in a layer-2 (Ethernet or token ring or FDDI) header before being encapsulated in the RFC1483 header. We will not use this interpretation in the rest of this document.

Interpretation 1: "RFC1483 Routed" Example For example, on an AR440S router, an Interpretation 1 "RFC1483 Routed" ADSL/ATM configuration would have an IP address directly configured onto the ATM channel, using commands like:

```
enable adsl=0
create atm=0 over=adsl0
add atm=0 channel=1
enable ip
add ip interface=atm0.1 ipaddress=<address> mask=<subnetmask>
```

Interpretation 1: "RFC1483 Bridged" Example For example, on an AR440S router, an Interpretation 1 "RFC1483 Bridged" ADSL/ATM connection could be configured in one of two ways. Either an IP address is configured over a virtual Ethernet interface on the ADSL port, using commands like:

```
enable adsl=0
create atm=0 over=adsl0
add atm=0 channel=1
create eth=0 over=atm0.1
enable ip
add ip interface=eth0 ipaddress=<address> mask=<subnet-mask>
```

or packets are bridged to the virtual Ethernet interface on the ADSL port, using commands like:

```
enable adsl=0
create atm=0 over=adsl0
add atm=0 channel=1
create eth=0 over=atm0.1
enable bridge
add bridge port=1 interface=eth0
add bridge port=2 interface=vlan1
add bridge prot=ip type=0800
add bridge prot=arp type=0806
```

Interpretation 2 (Used in this document)

The other common interpretation of the terms "RFC1483 Routed" and "RFC1483 Bridged" is to assume that both connection types are using the "Bridged protocol" encapsulation definition of RFC1483. In this interpretation, an "RFC1483 Routed" connection is one where the subscriber premises device routes packets onto the ADSL link, while an "RFC1483 Bridged" connection is one where the subscriber premises device bridges packets onto the ADSL link. This is the interpretation of the terms we use in the rest of this document.

In the case of the "RFC1483 Routed" connection, the subscriber premises device has an IP address configured on its ADSL interface, and makes forwarding decisions based on the IP addresses in the packets. In the case of the "RFC1483 Bridged" connection, the subscriber premises device forwards packets on the basis of their MAC addresses.

Interpretation 2: For example, on an AR440S router, the “RFC1483 Routed” connection has an IP address configured on its ADSL interface, using commands like:
“RFC1483 Routed” Example

```
enable adsl=0
create atm=0 over=adsl0
add atm=0 channel=1
create eth=0 over=atm0.1
enable ip
add ip interface=eth0 ipaddress=<address> mask=<subnet-mask>
```

Interpretation 2: For example, on an AR440S router, the “RFC1483 Bridged” connection is configured over bridge ports, using commands like:
“RFC1483 Bridged” Example

```
enable adsl=0
create atm=0 over=adsl0
add atm=0 channel=1
create eth=0 over=atm0.1
enable bridge
add bridge port=1 int=eth0
add bridge port=2 int=vlan1
add bridge prot=ip type=0800
add bridge prot=arp type=0806
```

Typical settings for ATM over ADSL

Most ATM-over-ADSL service providers will set all their subscribers to use the service category (traffic type) UBR, and exactly the same VPI and VCI values. The service provider can configure the DSLAM to change the VCI values in the cells as they go through to give a different VCI value to each subscriber’s cells, based on the port through which the cells entered the DSLAM. This simplifies the configuration for the subscribers, who configure their ADSL routers with the same VCI and VPI values as everybody else.

ADSL and ATM Support on the Router

The AR440S router supports ADSL Annex A for connection to a POTS line. The AR441S router supports ADSL Annex B for connection to an ISDN line. When an ADSL port is disabled, or powered down it sends a last **Dying Gasp** signal to indicate to the DSLAM that it is shutting down.

The router supports the following service categories:

- Unspecified Bit Rate (**UBR**).
- Constant Bit Rate (**CBR**).
- Variable Bit Rate (**VBR-rt** and **VBR-nrt**). Of the two Cell Loss Priority algorithms that can be used for VBR, the router supports Type 1.

The routers support ATM permanent virtual channels (PVCs), AAL5, and a number of higher layer protocols that can be configured over ATM and ADSL on the router as shown in [Figure 6-4](#), as described in [“Connection Types Used over ATM”](#) on page 6-10.

- PPPoE
- PPPoA
- IPoA
- RFC 1483 Routed*
- RFC 1483 Bridged*

* As defined in [“RFC 1483 Bridged or Routed - Alternative Definitions”](#) on page 6-10.

Figure 6-4: Protocols configured over ATM and ADSL

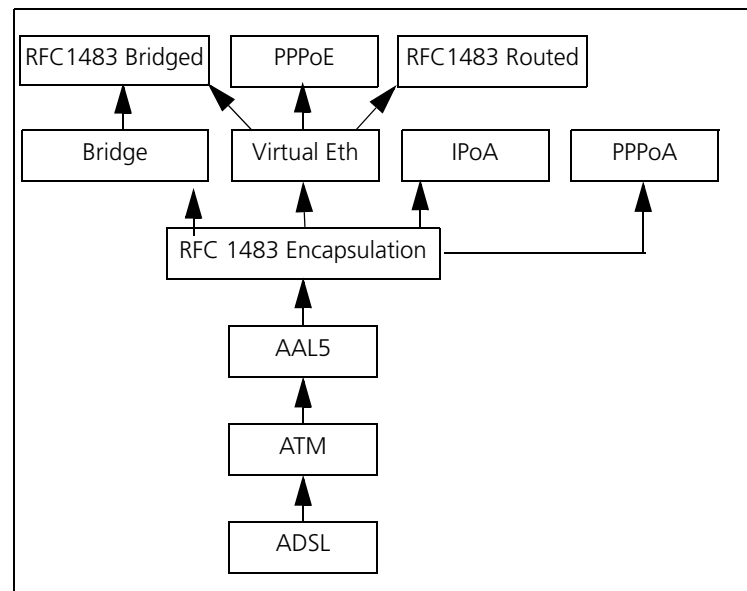

Virtual ETH interfaces

You can create a virtual ETH interface in order to add an Ethernet header to packets before bridging the resulting Ethernet frames over a lower layer interface, such as an ATM channel over an ADSL port. You can only create one virtual interface on a router, and it must have an ETH instance number that is not used by any of the physical ETH interfaces on the router.

Configuration Procedures and Examples

This section gives step by step procedures and simple configuration examples for configuring ATM over an ADSL port on the router.

- [“Configure PPPoE over ATM” on page 6-15](#)
Configuration procedure: [Table 6-2 on page 6-15](#)
Configuration example: [Figure 6-5 on page 6-16](#)
- [“Configure PPP over ATM \(PPPoA\)” on page 6-17](#)
Configuration procedure: [Table 6-3 on page 6-17](#)
Configuration example: [Figure 6-6 on page 6-18](#)
- [“Configure ATM RFC 1483 Routed*” on page 6-19](#)
Configuration procedure: [Table 6-4 on page 6-19](#)
Configuration example: [Figure 6-7 on page 6-20](#)

Before you configure

Before you configure, you will need the following information from your network service provider:

- VPI (Virtual Path Identifier) and VCI (Virtual Circuit Identifier),
- Encapsulation mode: VCMUX (Virtual Circuit Multiplex) or LLC5SNAP (also called AAL5SNAP),
- Access method, for example PPPoA, PPPoE, or IPoA,
- If using PPP, username and password, and
- If using PPP, IP address assignment method, that is, dynamic or static.

Configure PPPoE over ATM

Table 6-2: PPPoE over ATM over ADSL configuration procedure

| Step | Commands | Description |
|------|---|--|
| 1 | set system country ={australia austria belgium canada denmark eire finland france germany iceland italy netherlands newzealand norway portugal singapore spain switzerland sweden turkey uae uk usa none} | Set the country your router connects in, or omit this command to leave it at the default, none . The country setting determines default values for ATM channel parameters (vpi , vci , encapsulation). |
| 2 | set adsl = <i>interface</i> [autoretrain={on off}] [mode={analogloopback cellloopback digitalloopback normal}] standard={automatic t1.413 g.dmt g.lite} enable adsl ={ <i>interface</i> all} | The default settings for ADSL allow it to automatically detect the ADSL standard to use, and to automatically retrain to make best use of the available bandwidth. Use the set adsl command if you need to change from the default settings. Enable ADSL. |
| 3 | create atm =0..9 over= <i>phys-interface</i> | Create an ATM instance to run over the ADSL interface. You can only configure one ATM instance on an ADSL interface. |
| 4 | add atm channel add atm=0..9 channel=1..30 [serviceclass=ubr] [description= <i>description</i>] [pcr=32..155000] [encapsulation={aal5snap llc vcmux}][vpi=0..255 vci=32..1023] add atm=0..9 channel=1..30 serviceclass=cbr pcr=32..155000 [description= <i>description</i>] [encapsulation={aal5snap llc vcmux}] [vpi=0..255 vci=32..1023] add atm=0..9 channel=1..30 serviceclass={vbrnrt vbrrt} pcr=32..155000 scr=32..155000 mbs=2..10000 [description= <i>description</i>] [encapsulation={aal5snap llc vcmux}][vpi=0..255 vci=32..1023] | Add an ATM channel to the ATM instance. Change the defaults for the ATM channel if necessary. |
| 6 | create eth =0..7 over= <i>interface</i> | Create a virtual Ethernet interface to encapsulate traffic over the ATM channel in Ethernet frames. |
| 7 | create ppp = <i>ppp-interface</i> over= <i>physical-interface</i> [iprequest={on off}] [username= <i>username</i>] [password= <i>password</i>] [<i>other-ppp-parameters</i>] | Create a PPP interface over the virtual Ethernet interface. Set PPP parameters as required. For instance: To allow the IP address for the PPP link to be dynamically allocated, set iprequest to on . Set the username and password for that will be used to respond to authentication requests. |

Table 6-2: PPPoE over ATM over ADSL configuration procedure

| Step | Commands | Description |
|------|---|---|
| 8 | ENABLE IP ADD IP INTERFACE =interface ipaddress={ipadd dhcp} [other-ip-parameters] | Enable IP, and assign an IP address to the PPP interface, or set it to accept a dynamically allocated IP address. Then continue with other configuration as required (" After configuring ATM " on page 6-20). |

Figure 6-5: Example configuration script for PPPoE over ATM over ADSL

```

# PPPoE over ATM over ADSL

# Enable the ADSL port.
enable adsl=0

# Set the country for ATM default parameters.
set system country=italy

# Create an ATM instance and channel over the ADSL port.
create atm=0 over=adsl0
add atm=0 channel=1

# Create a virtual Ethernet interface over the ATM channel.
create eth=2 over=atm0.1

# Create a PPP interface over the virtual Eth interface, and
# set it to accept a dynamically allocated IP address.
create ppp=0 over=eth2-any bap=off iprequest=on
username="myname" password="mypassword" over=atm0.1 lqr=off

# Enable IP and add an IP interface with remote IP address
# assignment to the PPP interface.
enable ip
enable ip remote
add ip interface=ppp0 ipaddress=0.0.0.0

# Add a local IP address to the default VLAN.
add ip interface=vlan1 ipaddress=192.168.1.1

# Add a default IP route to the PPP interface.
add ip route=0.0.0.0 interface=ppp0 next=0.0.0.0

```

Configure PPP over ATM (PPPoA)

Table 6-3: PPP over ATM over ADSL configuration procedure

| Step | Commands | Description |
|------|--|---|
| 1 | set system country ={australia austria belgium canada denmark eire finland france germany iceland italy netherlands newzealand norway portugal singapore spain switzerland sweden turkey uae uk usa none} | Set the country your router connects in, or omit this command to leave it at the default, none . The country setting determines default values for ATM channel parameters (vpi , vci , encapsulation). |
| 2 | set adsl = <i>interface</i> [autoretrain={on off}] [mode={analogloopback cellloopback digitalloopback normal}] standard={automatic t1.413 g.dmt g.lite}] enable adsl ={ <i>interface</i> all} | Enable ADSL. The default settings for ADSL allow it to automatically detect the ADSL standard to use, and to automatically retrain to make best use of the available bandwidth. Use the set adsl command if you need to change from the default settings. |
| 3 | create atm =0..9 over= <i>phys-interface</i> | Create an ATM instance to run over the ADSL interface. You can only configure one ATM instance on an ADSL interface. |
| 4 | add atm channel add atm=0..9 channel=1..30 [serviceclass=ubr] [description= <i>description</i>] [pcr=32..155000] [encapsulation={aal5snap llc vcmux}] [vpi=0..255 vci=32..1023] add atm=0..9 channel=1..30 serviceclass=cbr pcr=32..155000 [description= <i>description</i>] [encapsulation={aal5snap llc vcmux}] [vpi=0..255 vci=32..1023] add atm=0..9 channel=1..30 serviceclass={vbrnrt vbrt} pcr=32..155000 scr=32..155000 mbs=2..10000 [description= <i>description</i>] [encapsulation={aal5snap llc vcmux}] [vpi=0..255 vci=32..1023] | Add an ATM channel to the ATM instance. Change the defaults for the ATM channel if necessary. |
| 7 | create ppp = <i>ppp-interface</i> over= <i>physical-interface</i> [iprequest={on off}] [username= <i>username</i>] password= <i>password</i> [<i>other-ppp-parameters</i>] | Create a PPP interface over the ATM channel. Set PPP parameters as required. For instance: To allow the IP address for the PPP link to be dynamically allocated, set iprequest to on . Set the username and password for that will be used to respond to authentication requests. |

Table 6-3: PPP over ATM over ADSL configuration procedure

| Step | Commands | Description |
|------|---|---|
| 8 | ENABLE IP ADD IP INTERFACE =interface ipaddress={ipadd dhcp} [other-ip-parameters] | Enable IP, and assign an IP address to the PPP interface, or set it to accept a dynamically allocated IP address. Then continue with other configuration as required (" After configuring ATM " on page 6-20). |

Figure 6-6: Example configuration script for PPP over ATM over ADSL

```

# PPP over ATM over ADSL

# Enable the ADSL port.
enable adsl=0

# Set the country for ATM default parameters.
set system country=italy

# Create an ATM instance and channel over the ADSL port.
create atm=0 over=adsl0
add atm=0 channel=1

# Create a PPP interface over ATM channel, and set it to
# accept a dynamically allocated IP address.
create ppp=0 over=atm0.1 bap=off iprequest=on
username="myname" password="mypassword" over=atm0.1 lqr=off

# Enable IP and add an IP interface with remote IP address
# assignment to the PPP interface.
enable ip
enable ip remote
add ip interface=ppp0 ipaddress=0.0.0.0

# Add a local IP address to the default VLAN.
add ip interface=vlan1 ipaddress=192.168.1.1

# Add a default IP route to the PPP interface.
add ip route=0.0.0.0 interface=ppp0 next=0.0.0.0

```

Configure ATM RFC 1483 Routed*

* As defined in “RFC 1483 Bridged or Routed - Alternative Definitions” on page 6-10.

Table 6-4: RFC 1483 Routed ATM over ADSL configuration procedure

| Step | Command | Description |
|------|--|---|
| 1 | set system country ={australia austria belgium canada denmark eire finland france germany iceland italy netherlands newzealand norway portugal singapore spain switzerland sweden turkey uae uk usa none} | Set the country your router connects in, or omit this command to leave it at the default, none . The country setting determines default values for ATM channel parameters (vpi , vci , encapsulation). |
| 2 | set adsl = <i>interface</i> [autoretrain={on off}] [mode={analogloopback cellloopback digitalloopback normal}] standard={automatic t.1.413 g.dmt g.lite}] enable adsl ={ <i>interface</i> all} | Enable ADSL. The default settings for ADSL allow it to automatically detect the ADSL standard to use, and to automatically retrain to make best use of the available bandwidth. Use the set adsl command if you need to change from the default settings. |
| 3 | create atm =0..9 over= <i>phys-interface</i> | Create an ATM instance to run over the ADSL interface. You can only configure one ATM instance on an ADSL interface. |
| 4 | add atm channel add atm=0..9 channel=1..30 [serviceclass=ubr] [description= <i>description</i>] [pcr=32..155000] [encapsulation={aal5snap llc vcmux}] [vpi=0..255 vci=32..1023] add atm=0..9 channel=1..30 serviceclass=cbr pcr=32..155000 [description= <i>description</i>] [encapsulation={aal5snap llc vcmux}] [vpi=0..255 vci=32..1023] add atm=0..9 channel=1..30 serviceclass={vbrnrt vbrt} pcr=32..155000 scr=32..155000 mbs=2..10000 [description= <i>description</i>] [encapsulation={aal5snap llc vcmux}] [vpi=0..255 vci=32..1023] | Add an ATM channel to the ATM instance. |
| 6 | create eth =0..7 over= <i>interface</i> | Create a virtual Ethernet interface to encapsulate traffic over the ATM channel in Ethernet frames. |
| 8 | ENABLE IP ADD IP INTERFACE = <i>interface</i> ipaddress={ipadd dhcp} [<i>other-ip-parameters</i>] | Enable IP, assign an IP address to the virtual Eth interface, or set it to accept a dynamically allocated IP address. Then continue with other configuration as required (“After configuring ATM” on page 6-20). |

Figure 6-7: RFC 1483 Routed ATM over ADSL with DHCP configuration example

```
# RFC 1483 Routed ATM over ADSL

# Enable the ADSL port.
enable adsl=0

# Set the country for ATM default parameters.
set system country=italy

# Create an ATM instance and channel over the ADSL port.
create atm=0 over=adsl0
add atm=0 channel=1

# Create a virtual Ethernet interface over the ATM channel.
create eth=2 over=atm0.1

# Enable IP and add an IP interface with DHCP assigned IP
# address to the virtual Eth interface.
enable ip
enable ip remote
add ip interface=eth2 ipaddress=dhcp

# Add a local IP address to the default VLAN.
add ip interface=vlan1 ipaddress=192.168.1.1
```

After configuring ATM

Once you have configured ATM over ADSL configuration, you may need to configure other aspects of the router, for instance:

- PPP backup link on ISDN (see [Chapter 9, Integrated Services Digital Network \(ISDN\)](#), [Chapter 7, Point-to-Point Protocol \(PPP\)](#))
- Switch ports and VLANs (see [Chapter 3, Switching on the AR440S, AR441S and AR450S](#))
- IP routes, local VLAN IP addresses, and DNS Relay (see [Chapter 12, Internet Protocol \(IP\)](#))
- IP Security for a Virtual Private Network (VPN) (see [Chapter 43, IP Security \(IPsec\)](#))
- Firewall and Network Address Translation (NAT) (see [Chapter 39, Firewall](#))
- SNMP Community (see [Chapter 36, Simple Network Management Protocol \(SNMP\)](#))
- DHCP server for local VLANs. [Chapter 33, Dynamic Host Configuration Protocol \(DHCP\)](#)

Command Reference

This section describes the commands available for configuring and monitoring ADSL and ATM on the router.

The shortest valid command is denoted by capital letters in the Syntax section. See [“Conventions” on page xciii of Preface](#) for additional conventions used to describe command syntax. See [Appendix A, Messages](#) for a complete list of messages and meanings.

add atm channel

Syntax

```
ADD ATM=instance CHANnel=channel [SERViceclass=UBR]
    [PCR=0|32..155000] [DESCRiption=description]
    [ENCapsulation={AAL5Snap|LLC|VCMux}] [VPI=0..255
    VCI=32..1023]

ADD ATM=0..9 CHANnel=1..30 SERViceclass=CBR PCR=1..155000
    [DESCRiption=description]
    [ENCapsulation={AAL5Snap|LLC|VCMux}] [VPI=0..255
    VCI=32..1023]

ADD ATM=0..9 CHANnel=1..30 SERViceclass={VBRNrt|VBRrt}
    PCR=1..155000 SCR=1..155000 MBS=2..10000
    [DESCRiption=description]
    [ENCapsulation={AAL5Snap|LLC|VCMux}] [VPI=0..255
    VCI=32..1023]
```

Description This command creates an ATM (AAL5) virtual channel for the ATM instance. This channel can be referred to as *atminstance.channel* in other commands, for example, atm0.1 is virtual channel 1 on ATM instance 0.

| Parameter | Values | Description |
|---------------|--------------------|---|
| ATM | 0..9 | The ATM instance to create the virtual channel on. |
| CHANnel | 1..30 | The virtual channel to create. |
| DESCRiption | <i>description</i> | Description of the channel for administration, up to 62 characters long. Has no effect on the operation of the channel. |
| ENCapsulation | | The RFC 1483 encapsulation mode to be used by the instance. Default is determined by the country parameter set using the set system country command on page 6-34. If the country parameter has the default value of none , then the default for encapsulation is llc . |
| | LLC or AAL5Snap | Logical Link Control mode; a single virtual channel can be used by different protocols. |
| | VCMux | Virtual Channel Multiplex mode; each protocol uses a separate virtual channel. |

| Parameter | Values | Description |
|--------------|------------|---|
| MBS | 2..10000 | The Maximum Burst Size for the channel, used to calculate the Burst Tolerance for the channel. Required if serviceclass is vbrrt or vbrnrt ; otherwise not valid. |
| PCR | 32..155000 | The VC Peak Cell Rate, in kbps. Valid values are from 32 to Max Tx VC bit rate , as displayed using the show atm command on page 6-39. Required if serviceclass is cbr , vbrrt or vbrnrt (from service provider contract). Optional if serviceclass is ubr . Default: maximum channel bandwidth (changes dynamically with the bandwidth) To restore the channel's UBR behaviour after pcr has been set, either: - delete the channel and add it with no pcr value, - disable the channel and specify pcr=0 using the set atm channel command on page 6-32. |
| SCR | 32..155000 | The VC Sustainable Cell Rate, in kbps. Required if serviceclass is cbr , vbrnrt or vbrrt ; otherwise not valid. |
| SERVICEclass | | Specifies the service category for the channel. Default: ubr |
| | CBR | Constant Bit Rate. |
| | UBR | Unspecified Bit Rate. |
| | VBRNrt | Variable Bit Rate non-realtime. |
| | VBRrt | Variable Bit Rate realtime. |
| VCI | 32..1023 | The Virtual Channel Identification number. Default is determined by the set system country command on page 6-34. If country is none , the default is 32. |
| VPI | 0..255 | The Virtual Path Identification number. Default is determined by the set system country command on page 6-34. If country is none , the default is 0. |

*The shortest string you can enter is shown in capital letters.

Examples To add virtual channel 1 to ATM instance 0 use the command:

```
add atm=0 chan=1
```

To add virtual channel 1 to ATM instance 0 with a VPI of 1, a VCI of 35, and real-time variable bit rate with Peak Cell Rate of 1Mb and Sustainable Cell Rate of 1Mb, use the command:

```
add atm=0 chan=1 vpi=1 vci=35 serv=vbrt pcr=1000 scr=1000
```

To add virtual channel 20 to ATM instance 0 with a VPI of 45, a VCI of 40, a Virtual Channel Multiplexed encapsulation, an Unspecified Bit Rate (default) with Peak Cell Rate of 10Mb, use the command:

```
add atm=0 chan=20 vpi=45 vci=40 encap=vcm pcr=10000
```

Related Commands [create eth](#)
[delete atm channel](#)
[disable atm channel](#)
[enable atm channel](#)
[set atm channel](#)
[set system country](#)
[show atm channel](#)

create atm

Syntax `CREate ATM=0..9 OVer=phys-interface`

Description This command creates an ATM instance running over a physical interface. One ATM instance can be created over an ADSL interface.

| Parameter | Values | Description |
|-----------|-----------------------|---|
| ATM | 0..9 | The number of the ATM instance to create. There can only be one ATM instance on a physical interface. (For instance, on the AR440S there can only be one ATM instance over the one ADSL interface.) |
| OVer | <i>phys-interface</i> | The name of physical interface to create the ATM instance over, formed by concatenating the physical interface type with an interface instance (e.g. adsl0). The only valid interface type is ADSL. |

*The shortest string you can enter is shown in capital letters.

Examples To create ATM interface 0 over ADSL interface 0, use the command:

```
cre atm=0 ov=adsl0
```

Related Commands [add atm channel](#)
[destroy atm](#)
[show atm](#)

create eth

Syntax `CREate ETH=0..7 OVer=interface`

Description This command creates a virtual Ethernet interface over a specified physical interface. Packets sent to this interface are encapsulated with an Ethernet header and passed to the physical interface where the packet is treated like a bridged Ethernet packet. The eth number must not already exist as a physical or virtual interface.

| Parameter | Value | Description |
|-----------|---------------------------------|---|
| ETH | 0..7 | A unique identifier for the virtual Ethernet interface. This number must not be the same as any physical Ethernet interface. It is only possible to create one virtual Ethernet interface. |
| OVer | <i>interface</i> e.g. atm0.1 | The physical interface over which the ETH interface traffic passes. The interface name is formed by concatenating the Layer 2 interface type atm, an ATM instance, and an ATM channel (e.g. atm0.1). |

*The shortest string you can enter is shown in capital letters.

Example To create a virtual Ethernet interface eth7 over the interface atm0.1 use the command.

```
cre eth=7 ov=atm0.1
```

See Also [create ppp](#) in Chapter 7, Point-to-Point Protocol (PPP)
[destroy eth](#)

delete atm channel

Syntax `DELEte ATM=0..9 CHANnel=1..30`

Description This command deletes an ATM virtual channel from the ATM instance. The instance must exist and will no longer be available after it is deleted. A channel cannot be deleted if any higher layer protocol is attached to it.

| Parameter | Value | Description |
|-----------|-------|-------------------------------------|
| ATM | 0..9 | The ATM instance the channel is on. |
| CHANnel | 1..30 | The virtual channel to delete. |

*The shortest string you can enter is shown in capital letters.

Examples To delete virtual channel 1 on ATM instance 0, use the command:

```
del atm=0 chan=1
```

Related Commands

- [add atm channel](#)
- [disable atm channel](#)
- [enable atm channel](#)
- [show atm channel](#)

destroy atm

Syntax `DESTroy ATM=0..9`

Description This command destroys an ATM instance. The instance must already exist. The instance is no longer available for use by routing modules. The ATM instance can only be destroyed if there are no virtual channels present on the instance. Virtual channels can be deleted using the **delete atm channel** command.

The ATM parameter specifies which ATM instance number to destroy, in the range 0 to 9.

Examples To destroy ATM instance 0, use the command:

```
dest atm=0
```

Related Commands

- [create atm](#)
- [delete atm channel](#)
- [set atm channel](#)
- [show atm](#)

destroy eth

Syntax DESTroy ETH=0..7

Description This command destroys a virtual Ethernet interface. This command cannot be used if there are higher layer modules attached to the virtual Ethernet interface. This command can only be used to destroy virtual Ethernet interfaces created using the **create eth** command.

The **eth** parameter specifies which virtual Ethernet interface to destroy.

Example To destroy the virtual Ethernet interface *eth2* use the command.

```
dest eth=2
```

See Also [create eth](#)
[show interface in Chapter 5, Interfaces](#)

disable adsl

Syntax DISable ADSL={*interface*|ALL}

Description This command disables the specified ADSL interface or all ADSL interfaces. This will clear any ADSL connection or special test mode (for example, WHIP or loop-backs). No data can be transmitted or received when the interface is disabled. The ADSL interface can be configured when disabled.

The **adsl** parameter specifies which ADSL interface number to disable. If **all** is specified all ADSL interfaces are disabled. By default all ADSL interfaces are enabled.

Examples To disable ADSL interface 0, use the command:

```
dis ads=0
```

Related Commands [enable adsl](#)
[reset adsl](#)
[show adsl](#)

disable adsl debug

Syntax `DISable ADSl={interface|ALL} DEBUg={TRaining|ALL}`

Description This command disables ADSL interface debugging modes. By default all debug modes are disabled.

| Parameter | Value | Description |
|-----------|------------------|--|
| ADSL | <i>interface</i> | The number of the ADSL interface to disable debugging for. |
| | ALL | Disables debugging on all ADSL interfaces. |
| DEBUg | | The debugging mode to disable. |
| | ALL | All debug modes. |
| | TRaining | The training debug mode. |

*The shortest string you can enter is shown in capital letters.

Examples To disable all debugging on ADSL interface 0, use the command:

```
dis ads=0 deb=all
```

Related Commands [enable adsl debug](#)
[show adsl](#)

disable atm channel

Syntax `DISable ATM=0..9 CHANnel={1..30|ALL}`

Description This command disables an ATM virtual channel. No data is transmitted or received on the channel. By default an ATM channel is enabled when it is added.

| Parameter | Value | Description |
|-----------|-------|---|
| ATM | 0..9 | The number of the ATM instance. |
| CHANnel | 1..30 | The number of the ATM virtual channel to disable. |

*The shortest string you can enter is shown in capital letters.

Examples To disable virtual channel 1 in ATM instance 0, use the command:

```
dis atm=2 chan=1
```

Related Commands [delete atm channel](#)
[enable atm channel](#)
[show atm channel](#)

enable adsl

Syntax ENable ADSl={*interface*|ALL}

Description This command enables a previously disabled ADSL interface, so that data can be transmitted or received on the interface. By default ADSL interfaces are disabled.

The **adsl** parameter specifies which ADSL interface to enable. If **all** is specified, all ADSL interfaces are enabled.

Examples To enable ADSL interface 0, use the command:

```
ena ads=0
```

Related Commands [create atm](#)
[disable adsl](#)
[reset adsl](#)
[show adsl](#)

enable adsl debug

Syntax ENable ADSl={*interface*|ALL} DEBug={ALL|TRaining} [TTy=*tty-num*]

Description This command enables ADSL interface debugging on an ADSL interface, or on all ADSL interfaces. By default all debugging modes are disabled.

| Parameter | Value | Description |
|-----------|------------------|---|
| ADSl | <i>interface</i> | The number of the ADSL interface on which to enable debugging. |
| | ALL | Enables debugging on all ADSL interfaces. |
| DEBug | | The debugging mode to enable. |
| | ALL | All debug modes. |
| | TRaining | Displays the current ADSL connection status. |
| TTy | <i>tty-num</i> | The TTY instance number of the ASYN port or telnet session (terminal device) to send the debug output to. This enables debugging to be enabled in a script. To display the TTY instance number of the terminal device that is currently being used, use the command SHOW TTY . Default: the terminal or Telnet session from which the command was executed. |

*The shortest string you can enter is shown in capital letters.

Examples To enable all debugging modes on ADSL interface 0, use the command:

```
ena ads=0 deb=all
```

Related Commands [disable adsl debug](#)

enable atm channel

Syntax `ENABle ATM=instance CHANnel={1..30|ALL}`

Description This command enables a previously disabled ATM virtual channel, or all channels on an ATM instance. Data can be transmitted or received on the channel. By default an ATM channel is enabled.

| Parameter | Value | Description |
|-----------|-------|--|
| ATM | 0..9 | The number of the ATM instance. |
| CHANnel | 1..30 | The number of the ATM virtual channel to enable. |

*The shortest string you can enter is shown in capital letters.

Examples To enable all virtual channels on ATM instance 0, use the command:

```
ena atm=0 chan=all
```

Related Commands

- [add atm channel](#)
- [delete atm channel](#)
- [disable atm channel](#)
- [enable adsl](#)
- [set atm channel](#)
- [show atm channel](#)

reset adsl

Syntax `RESET ADSl={interface|ALL}`

Description This command brings down the specified ADSL link and restarts the interface. If **all** is specified, it resets all ADSL interfaces and reapplies ADSL configuration settings.

Examples To reset ADSL interface 0, use the command:

```
reset ads=0
```

Related Commands

- [disable adsl](#)
- [enable adsl](#)
- [reset adsl counter](#)
- [set adsl](#)
- [show adsl](#)

reset adsl counter

Syntax RESET ADSL={*interface*|ALL} COUnTer

Description This command resets the counters for the specified ADSL interfaces to 0. If **all** is specified, counters for all ADSL interfaces are set to 0.

Examples To reset ADSL interface 0 counters, use the command:

```
reset ads=0 cou
```

Related Commands [reset adsl](#)
[show atm counter](#)

set adsl

Syntax SET ADSL=*interface* [AUtoretrain={ON|OFF}]
[MODE={ANALogloopback|CELlloopback|DIGitalloopback|
NORMal}] STandard={AUtomatic|T1.413|G.Dmt|G.Lite}]

Description This command changes the operational parameters of an ADSL interface. The ADSL interface must be disabled ([disable adsl](#)).

| Parameter | Value | Description |
|-----------|------------------|--|
| ADSL | <i>interface</i> | The ADSL interface to configure. |
| MODE | | The operational mode for the ADSL interface. Default: normal |
| | NORMal | For standard operation. Data is passed normally through the ADSL hardware. |
| | DIGitalloopback | For hardware testing only. Loops data back at in the digital component of the ADSL hardware. |
| | ANALogloopback | For hardware testing only. Loops data back at the interface to the analogue front end of the ADSL hardware. |
| | CELlloopback | For hardware testing only. Loops back data at the interface between the CPU and the ADSL hardware. |
| STandard | | The ADSL standard that the interface will attempt to connect on. The possibility of setting the standard manually exists so that if there is a particular problem with the auto-detection the operating standard can be manually set. Default: automatic |
| | AUtomatic | Automatically detects and uses the relevant standard for operation. |
| | T1.413 | Uses the T1.413 DSL forum standard |
| | G.Dmt | Uses G.DMT, the ITU standard G.992.3 |
| | G.Lite | Uses G.LITE, the ITU standard G.992.4 |

| Parameter | Value | Description |
|---------------|-------|---|
| AUautoretrain | ON | Whether automatic retraining is on or off. When enabled (on), the interface retrains and resets its operational conditions when the link conditions change enough to warrant this. Default: on |
| | OFF | Disables automatic retraining on the ADSL interface. |

*The shortest string you can enter is shown in capital letters.

Examples To set ADSL interface 0 to digitalloopback testing mode using the T1.413 standard, with automatic retraining on, use the command:

```
set ads=0 mod=dig st=T1.413 au=on
```

To set ADSL interface 0 back to normal operation after testing, with automatic standard selection and automatic retraining, use the command:

```
set ads=0 au=on mod=norm st=au
```

Related Commands

- [disable adsl](#)
- [enable adsl](#)
- [enable adsl debug](#)
- [reset adsl](#)
- [reset adsl counter](#)
- [show adsl](#)
- [show adsl counter](#)

set atm channel

Syntax SET ATM=*instance* CHANnel=*channel* [SERviceclass=UBR]
 [PCR=0|32..155000] [DESCription=*description*]
 [ENCapsulation={AAL5Snap|LLC|VCMux}] [VPI=0..255
 VCI=32..1023]

SET ATM=*instance* CHANnel=*channel* [SERviceclass=CBR]
 [PCR=32..155000] [DESCription=*description*]
 [ENCapsulation={AAL5Snap|LLC|VCMux}] [VPI=0..255
 VCI=32..1023]

SET ATM=*instance* CHANnel=*channel*
 [SERviceclass={VBRNrt|VBRrt}] [PCR=32..155000]
 [SCR=32..155000] [MBS=2..10000]
 [DESCription=*description*]
 [ENCapsulation={AAL5Snap|LLC|VCMux}] [VPI=0..255
 VCI=32..1023]

Description This command changes the operational parameters of an ATM (AAL5) virtual channel for the ATM instance. The channel must already have been added to the ATM instance using the [add atm channel](#), and disabled using the [disable atm channel](#).

| Parameter | Values | Description |
|---------------|-----------------|---|
| ATM | 0..9 | The ATM instance to create the virtual channel on. |
| CHANnel | 1..30 | The virtual channel to create. |
| DESCription | | Description of the channel for administration, up to 62 characters long . Has no effect on the operation of the channel. |
| ENCapsulation | | The RFC 1483 encapsulation mode to be used by the instance. Default is determined by the country parameter set using the set system country command on page 6-34. If the country parameter has the default value of none , then the default for encapsulation is llc . |
| | LLC or AAL5Snap | Logical Link Control mode; a single virtual channel can be used by different protocols. |
| | VCMux | Virtual Channel Multiplex mode; each protocol uses a separate virtual channel. |
| MBS | 1..1000 | The Maximum Burst Size for the channel. Valid if serviceclass is vbrt or vbrnt ; otherwise not valid. |
| PCR | | The VC Peak Cell Rate, in kbps. Default: maximum channel bandwidth (changes dynamically with the bandwidth) |
| | 32..155000 | Valid values are from 32 to Max Tx VC bit rate , as displayed using the show atm command on page 6-39. |
| | 0 | Restores the default after pcr has been set to another value, for serviceclass=ubr only. |

| Parameter | Values | Description |
|--------------|-----------|--|
| SCR | 1..155000 | The VC Sustainable Cell Rate, in kbps. Valid if serviceclass is cbr , vbrnrt or vbrrt ; otherwise not valid. |
| SERviceclass | | Specifies the service category for the channel. Default: ubr |
| | CBR | Constant Bit Rate. |
| | UBR | Unspecified Bit Rate. |
| | VBRNrt | Variable Bit Rate non-realtime. |
| | VBRrt | Variable Bit Rate realtime. |
| VCI | 32..1023 | The Virtual Channel Identification number. Default is determined by the set system country command on page 6-34. If country is none , the default is 32. |
| VPI | 0..255 | The Virtual Path Identification number. Default is determined by the set system country command on page 6-34. If country is none , the default is 0. |

*The shortest string you can enter is shown in capital letters.

Examples To set ATM instance 0 virtual channel 1 to have a VPI of 1, a VCI of 35 and a real-time variable bit rate with Peak Cell Rate of 1Mb and Sustainable Cell Rate of 1Mb, use the command:

```
set atm=0 chan=1 vpi=1 vci=35 serv=vbrt pcr=1000 scr=1000
```

To set ATM instance 0 virtual channel 2 to have VPI=45, VCI=40 a VC Multiplexed Encapsulation, an Unspecified Bit Rate (default) with Peak Cell Rate of 10Mb and Minimum Cell Rate of 1Mb, use the command:

```
set atm=0 chan=2 vpi=45 vci=40 enc=vcm pcr=10000 mcr=1000
```

Related Commands

- [add atm channel](#)
- [create eth](#)
- [delete atm channel](#)
- [disable atm channel](#)
- [enable atm channel](#)
- [set system country](#)
- [show atm channel](#)

set system country

Syntax SET SYSTEM COUNTRY={AUSTRALIA|AUSTRIA|BELGIUM|CANADA|DENMARK|EIRE|FINLAND|FRANCE|GERMANY|ICELAND|ITALY|NETHERLANDS|NEWZEALAND|NORWAY|PORTUGAL|SINGAPORE|SPAIN|SWITZERLAND|SWEDEN|TURKEY|UAE|UK|USA|NONE}

Description This command sets the country identifier for the router, and sets corresponding defaults for ATM.

The **country** parameter specifies which country to set the ATM defaults for (Table 2-12). If **none** is specified then the ATM default VPI/VCI pair is set to 0/32 and the encapsulation to LLC. The default is **none**.

Table 6-5: Default settings for ATM virtual channels dependent on the **country** parameter

| country parameter | Default VPI | Default VCI | Default encapsulation mode |
|-------------------|-------------|-------------|----------------------------|
| NONE (default) | 0 | 32 | LLC |
| AUSTRALIA | 8 | 35 | LLC |
| AUSTRIA | 8 | 48 | VCMux |
| BELGIUM | 8 | 35 | VCMux |
| CANADA | 0 | 35 | LLC |
| DENMARK | 0 | 35 | LLC |
| EIRE | 0 | 38 | VCMux |
| FINLAND | 0 | 40 | LLC |
| FRANCE | 8 | 35 | VCMux |
| GERMANY | 1 | 32 | LLC |
| ICELAND | 0 | 35 | VCMux |
| ITALY | 8 | 35 | VCMux |
| NETHERLANDS | 0 | 48 | VCMux |
| NEWZEALAND | 0 | 100 | VCMux |
| NORWAY | 8 | 35 | LLC |
| PORTUGAL | 8 | 32 | LLC |
| SINGAPORE | 0 | 100 | VCMux |
| SPAIN | 8 | 32 | LLC |
| SWITZERLAND | 8 | 48 | VCMux |
| SWEDEN | 8 | 35 | LLC |
| TURKEY | 8 | 35 | LLC |
| UAE | 0 | 100 | VCMux |
| UK | 0 | 38 | VCMux |
| USA | 0 | 35 | LLC |

Example To set the county to Australia use the command.

```
set sys cou=austra
```

Related Commands [add atm channel](#)
[set atm channel](#)

show adsl

Syntax `SHow ADSL [= { interface | ALL }]`

Description This command displays interface information for the specified ADSL interface, or all ADSL interfaces. If no value is specified, summary information about all ADSL interfaces is displayed. If an interface is specified, detailed information about the ADSL interface is displayed. If **all** is specified, detailed information about all ADSL interfaces is displayed.

Figure 6-8: Example output from the **show adsl** command

| ADSL Interface Information | |
|----------------------------|-----------|
| Instance | State |
| adsl0 | Off |
| adsl1 | Training |
| adsl2 | Connected |

Table 6-6: States displayed in the output of the **show adsl** command

| State | Meaning |
|--------------|---|
| Clearing | The ADSL interface is clearing the current connection or loopback mode. |
| Connected | The ADSL interface has established an ADSL connection or loopback mode. |
| Connecting | The ADSL interface is trying to establish an ADSL connection. |
| Faulty | The ADSL interface is faulty. It can not be used. |
| Initialising | The ADSL interface is performing initialisation. |
| Off | The ADSL interface is idle; it has been disabled. |
| WHIP | The ADSL interface is operating in the special WHIP test mode. |

Figure 6-9: Example output from the **show adsl=0** command

| ADSL Interface Information | |
|----------------------------|-----------|
| ----- | |
| asyn0: | |
| Status | ENABLED |
| State | Connected |
| Mode | NORMAL |
| Standard | AUTOMATIC |
| Bert | OFF |
| Autoretrain | ON |
| Link state | Up |
| Up time | 523 sec |
| Signal to noise | +12.5 dB |
| Rx rate | 1280 kbps |
| Tx rate | 8120 kbps |

Table 6-7: Parameters displayed in the output of the **show adsl=0** command

| Parameter | Meaning |
|-----------------|--|
| Status | Whether or not the ADSL interface is enabled. |
| State | The current ADSL interface state (see Table 11). |
| Mode | The configured ADSL operating mode setting. |
| Standard | The configured ADSL standard setting. |
| Bert | The configured ADSL BERT setting. |
| Autoretrain | The configured ADSL auto-retrain setting. |
| Link state | Whether the data link is up or down. |
| Up time | The length of time that the link has currently been up. |
| Signal to noise | The local signal to noise margin. |
| Rx rate | The downstream (receive) ADSL bit rate. This is the raw figure including ATM/protocol overheads. |
| Tx rate | The upstream (transmit) ADSL bit rate. This is the raw figure including ATM/protocol overheads. |

Examples To display a summary of all ADSL interfaces, use the command:

```
sh ads
```

To display detailed information on ADSL interface 5, use the command:

```
sh ads=0
```

To display detailed information on all ADSL interfaces, use the command:

```
sh ads=all
```

Related Commands

- [create atm](#)
- [disable adsl](#)
- [enable adsl](#)
- [reset adsl](#)
- [reset adsl counter](#)
- [set adsl](#)
- [show adsl counter](#)

show adsl counter

Syntax `SHoW ADsL [= {interface | ALL}] COUnTer`

Description This command displays counter information for one or more ADSL interfaces.

The **adsl** parameter specifies which ADSL interface to show counter information about. If **all** is specified then counters for all ADSL interfaces are displayed.

Figure 6-10: Example output from the **show adsl=0 counter** command

```

ADSL Interface Counter Information
-----
adsl0:
Tx Cell ..... 123456
Rx Cell ..... 654321
BERT errors ..... 5
Connections ..... 2
Failed to connect ..... 1
Retrains ..... 0
Last Up time ..... 125 sec
Total Up time ..... 592 sec
Current Down time ..... 0 sec
Last Down time ..... 72 sec
Total Down time ..... 245 sec

```

Table 6-8: Parameters displayed in the output of the **show adsl=0 counter** command

| Parameter | Meaning |
|-------------------|---|
| Tx Cell | Number of transmitted ATM cells. |
| Rx Cell | Number of received ATM cells. |
| BERT errors | Number of Bit Error Rate Test errors when running in loop back mode with BERT on. |
| Connections | Number of times the ADSL connection has been established. |
| Failed to Connect | Number of times the ADSL connection has failed to connect. |
| Retrains | Number of times the ADSL connection has spontaneously retrained. |
| Last Up time | Time that the last (previous) link remained up. |
| Total Uptime | Total time the link has been up (including current period if currently up). |
| Current Down time | Time the link has currently been down (or zero if currently up). |
| Last Down time | Length of the previous link down time. |
| Total Down time | Total time the link has been down (including current period if currently down). |

Example To show the counters for ADSL interface 0 use the command

```
sh ads=0 cou
```

Related Commands [reset adsl counter](#)
[show adsl](#)

show atm

Syntax SHow ATM[=0..9]

Description This command displays information about the general ATM configuration, or the specified ATM instance.

Figure 6-11: Example output from the **show atm** command

```

ATM Module configuration
-----
Number of instances..... 1

Table of instances
-----
Instances      L1 interface      No. VCs      status
-----
0              ads10              3            Up
-----
    
```

Table 6-9: Parameters displayed in the output from the **show atm** command

| Parameter | Meaning |
|---------------------|---|
| Number of instances | The number of ATM instances. |
| Instances | The number of the ATM instance. |
| L1 interface | The layer one interface that the instance is attached to: the ADSL interface. |
| No. VCs | The number of ATM virtual channels added to this ATM instance. |
| Status | The status of the instance; either Up or Down. |

Figure 6-12: Example output from the **show atm=0** command

```

ATM instance 0
-----
Status ..... ENABLED
Over ..... ads10
L1 Link status ..... Up
L1 Link Rx rate ..... 10016 Kbps
L1 Link Tx rate ..... 1024 Kbps
Max Tx VC bit Rate ..... 1024 Kbps
Min Tx VC bit Rate ..... 32 Kbps
Max number of Channels ..... 30
Number of Channels ..... 2
Channel Table
-----
Channel  Encap.      VPI/VCI  Status   Link  Description
-----
1        LLC SNAP    0/35     Enabled  Up    None
2        LLC SNAP    0/101    Disabled Down  Description
-----
    
```

Table 6-10: Parameters shown in the output of the **show atm=0** command

| Parameter | Meaning |
|------------------------|--|
| Status | Status of the instance |
| Over | The Layer one interface that the atm is sent over |
| Max bit rate | The maximum bit rate that a CHANNEL can be configured to use |
| L1 Link status | The physical layer connection link status. |
| L1 Link Rx rate | The receive rate that the L1 layer has reported to atm |
| L1 Link Tx rate | The transmit rate that the L1 layer has reported to atm |
| Max Tx VC bit Rate | The maximum transmit bit rate allowed for a given channel. I.e The maximum PCR allowed. |
| Min Tx VC bit Rate | The minimum transmit bit rate that a CHANNEL can be scheduled to use, that is, the minimum mcr or scr bit rate |
| Max number of Channels | The maximum number of channels that can be configured on this instance. |
| Number of channel's | The number of channel's added to the instance |
| Channel | The channel number |
| Encap. | The channel's configured encapsulation |
| VPI/VCI | The VCI and VPI pair for the PVC |
| Status | The user configured status of the channel. Enabled or disabled. |
| Link | The Link status of the Instance. |
| Description | The user description given to the VC. |

Examples To display a summary of all ATM instances, use the command:

```
sh atm
```

To display detailed information on ATM instance 0, use the command:

```
sh atm=0
```

Related Commands

- [add atm channel](#)
- [create atm](#)
- [delete atm channel](#)
- [destroy atm](#)
- [disable atm channel](#)
- [enable atm channel](#)
- [set atm channel](#)
- [show atm channel](#)
- [show atm counter](#)

show atm channel

Syntax SHow ATM=0..9 CHANnel={1..30|ALL}

Description This command displays information about the specified ATM virtual channel, or all ATM channels.

Figure 6-13: Example output from the **show atm=0 channel=1** command

```

ATM interface atm0.2
-----
Channel Number ..... 1
Channel Description ..... description of channel
Channel Type ..... PVC
VPI ..... 0
VCI ..... 102
Encapsulation ..... LLC SNAP
Service Class ..... VBRRT
  PCR ..... 200 (199) Kbps
  MCR ..... 0 (0) Kbps
  SCR ..... 200 (200) Kbps
  MBS ..... 101 Cells
  BT ..... 512 (512) Cells
Attached User Modules ..... PPP IP ETH
L1 interface ..... adsl0
Configured Status ..... Enabled
Link Status ..... Up
-----

```

Table 6-11: Parameters displayed in the output of the **show atm=0 channel=1** command

| Parameter | Meaning |
|---------------------|---|
| ATM interface | The ATM instance that the virtual channel belongs to. |
| Channel Number | The channel number |
| Channel Description | The description of the channel |
| Channel Type | The type of channel; PVC. |
| VPI | The virtual path identifier. |
| VCI | The virtual channel identifier. |
| Encapsulation | The encapsulation, either VCMux or LLC SNAP |
| Service Class | Service category (serviceclass) for the channel; one of CBR, UBR, VBRRT or VBRNRT. |
| PCR | Peak Cell Rate. |
| MCR | Minimum Cell Rate. |
| SCR | Sustain Cell Rate. |
| MBS | Maximum Burst Size. |

Table 6-11: Parameters displayed in the output of the **show atm=0 channel=1** command

| Parameter | Meaning |
|-----------------------|--|
| BT | VBR burst tolerance. This is calculated from the pcr , scr , and mbs . The number in the parentheses is the actual rate the VC is running at. The actual BT and the requested BT may be different because the some ADSL ports can change their rates dynamically and because of rounding factors. If the configured rate is given before the ADSL port is trained up, or the rate changes while up, then the parameters may change. |
| Attached User modules | Other modules (e.g. protocols) attached to this channel. |
| L1 Interface | The layer 1 physical interface over which the ATM channel is configured. |
| Configured Status | The user configured status of the channel; either Enabled or Disabled. |
| Link status | The status of the instance link for this channel; either Up or Down. |

Examples To display detailed information about virtual channel 1 on ATM instance 0, use the command:

```
sh atm=0 chan=1
```

Related Commands

- [add atm channel](#)
- [create atm](#)
- [delete atm channel](#)
- [destroy atm](#)
- [disable atm channel](#)
- [enable atm channel](#)
- [set atm channel](#)
- [show atm](#)
- [show atm counter](#)

show atm counter

Syntax SHOW ATM=0..9 [CHANnel={1..30|ALL}] COUnTer

Description This command displays ATM counters.

| Parameter | Value | Description |
|-----------|-------|---|
| ATM | 0..9 | The number of the ATM instance. |
| CHANnel | | The virtual channel number on the ATM instance to display counters for. Default: No channel specific counters are displayed. |
| | 1..30 | The number of the ATM virtual channel to display. |
| | ALL | All the channels on the ATM instance are displayed one after the other |

*The shortest string you can enter is shown in capital letters.

Figure 6-14: Example output from the **show atm=0 counter** command

```

ATM instance 0
-----
UTOPIA dropped cells ..... 9
CRC 10 error ..... 90
Mis-inserted cells ..... 10
Total packet queue length ..... 0
Interface MIB Counters
  ifInOctets ..... 0          ifOutOctets ..... 0
  ifInUcastPkts ..... 0       ifOutUcastPkts ..... 0
  ifInErrors ..... 0          ifOutErrors ..... 0
  ifInUnknownProtos ..... 0   .....
  ifInDiscards ..... 0        ifOutDiscards ..... 0
  ifInMulticastPkts ..... 0    ifOutMulticastPkts ..... 0
  ifInMulticastPkts ..... 0    ifOutMulticastPkts ..... 0
  ifInBroadcastPkts ..... 0    ifOutBroadcastPkts ..... 0
-----

```

Table 6-12: Parameters displayed in the output of the **show atm=0 counter** command

| Parameter | Meaning |
|-------------------------|---|
| Utopia dropped Cells | Cells dropped due UTOPIA bus errors. This is internal communication with the PHY. |
| CRC 10 Errors | Cells dropped due to CRC10 checksums. These are for ATM operation cells present in OAM and RM functions. |
| Misinserted cells | This counter shows the number of cells dropped due to addressing errors. This means that either the VPI or VCI does not match any active channels or the cell is corrupted. |
| Out packet Queue Length | The total current packet queue length of the instance's channels. |
| Interface MIB Counters | These are defined in RFC 2515 section 5.2.1 |
| ifInOctets | The number of received octets over the interface, i.e., the number of received, assigned cells multiplied by 53. |

Table 6-12: Parameters displayed in the output of the **show atm=0 counter** command

| Parameter | Meaning |
|-------------------|--|
| ifOutOctets | The number of transmitted octets over the interface, i.e., the number of transmitted, assigned cells multiplied by 53. |
| ifInErrors | The number of cells dropped due to uncorrectable HEC errors. |
| ifOutErrors | The number of cells packets that could not be transmitted because of errors |
| ifInUnknownProtos | The number of received cells discarded during cell header validation, including cells with unrecognized VPI/VCI values, and cells with invalid cell header patterns. |

Figure 6-15: Example output from the **show atm=0 channel=1 counter** command

```

ATM instance 0 channel 1 (atm0.1)
-----
Output queue length ..... 0
Interface MIB Counters
  ifInOctets ..... 0          ifOutOctets ..... 0
  ifInUcastPkts ..... 0       ifOutUcastPkts ..... 0
  ifInErrors ..... 0          ifOutErrors ..... 0
  ifInUnknownProtos ..... 0   .....
  ifInDiscards ..... 0        ifOutDiscards ..... 0
  ifInMulticastPkts ..... 0    ifOutMulticastPkts ..... 0
  ifInBroadcastPkts ..... 0    ifOutBroadcastPkts ..... 0
Miscellaneous counters
  InCongestionSet ..... 0      InCLPSet ..... 0
  InCRCErrors ..... 0          InAbortedPdu ..... 0
  InChainedPdu ..... 0         InLengthError ..... 0
  InOversizedSDU ..... 0       InLLCUnsupported ..... 0
  InLLCInvalid ..... 0         .....
  outFragmentDiscard ..... 0   outFrameTooLong ..... 0
-----

```

Table 6-13: Parameters displayed in the output of the **show atm=0 channel=1 counter** command

| Parameter | Meaning |
|------------------------|--|
| Output queue length | The current packet queue length on the interface. |
| Interface MIB counters | These are defined in RFC 2515 section 7.3 |
| ifInOctets | The number of received AAL5 CPCS PDU octets. |
| ifOutOctets | The number of AAL5 CPCS PDU octets transmitted. |
| ifInUcastPkts | The number of received AAL5 CPCS PDUs passed to a higher-layer. |
| ifOutUcastPkts | The number of AAL5 CPCS PDUs received from a higher-layer for transmission. [Note: The number of AAL5 PDUs actually transmitted is the number received from a higher-layer for transmission minus any which are counted by ifOutErrors and ifOutDiscards.] |
| ifInErrors | Number of errors in AAL5 CPCS PDUs received. The types of errors counted include CRC-32 errors, SAR time-out errors, and oversized SDU errors. |
| ifInUnknownProtos | Always set to 0. As defined by the MIB |

Table 6-13: Parameters displayed in the output of the **show atm=0 channel=1 counter** command (Continued)

| Parameter | Meaning |
|--------------------|---|
| ifInDiscards | Number of received AAL5 CPCS PDUs discarded. Possible reason may be input buffer overflow. |
| ifOutErrors | Number of AAL5 CPCS PDUs that could not be transmitted due to errors. |
| ifOutDiscards | Number of AAL5 CPCS PDUs received for transmission that are discarded. Possible reason may be output buffer overflow. |
| ifInMulticastPkts | Always set to 0. As defined by the MIB |
| ifInBroadcastPkts | Always set to 0. As defined by the MIB |
| IfOutMulticastPkts | Always set to 0. As defined by the MIB |
| IfOutBroadcastPkts | Always set to 0. As defined by the MIB |
| InCongestionSet | The number of AAL5 frames received with the congestion bit set. |
| InCLPSet | The number of AAL5 frames received with the cell loss priority (CLP) set. |
| InCRCErrors | The number of AAL5 frames dropped due to CRC 32 errors. |
| InAbortedPdu | The number of AAL5 frames aborted with a zero cell. |
| InChainedPdu | The number of AAL5 frames that were internally chained (larger than 1600 bytes) |
| InLengthError | The number of AAL5 frames that were dropped due to ATM length reporting errors (dropped cells etc.) |
| InOversizedSDU | The number of AAL5 frames that are over the 1600 byte internal size |
| InLLCUnsupported | The number of AAL5 frames received that had an LLC type that is not supported |
| InLLCInvalid | The number of AAL5 frames received with invalid or corrupt LLC headers |
| OutFragmentDiscard | The number of Frames discarded from transmitting because they had too many fragments |
| OutFrameToolong | The number of frames discarded from transmitting because they exceed the internal frame size limit. |

Examples To display the counters for ATM instance 0, use the command:

```
sh atm=0 cou
```

Related Commands

- [add atm channel](#)
- [create atm](#)
- [delete atm channel](#)
- [destroy atm](#)
- [disable atm channel](#)
- [enable atm channel](#)
- [set atm channel](#)
- [show atm](#)
- [show atm channel](#)

